

FLIGHT MANUAL

Doc. n° 92/61 Issue n°3: 25th May 2010

Revision No.4: 15th July 2019

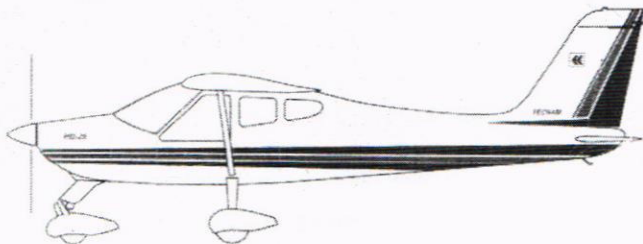

P92-JS

MANUFACTURER: COSTRUZIONI AERONAUTICHE **TECNAM** S.r.l.

AIRCRAFT MODEL: **P92-JS**

TYPE CERTIFICATION: n° EASA A.412 (SO/A-340)

SERIAL NUMBER: **31**

BUILD YEAR: **2003**

REGISTRATION MARKINGS: **PH-TES**

This manual contains information to be furnished to the pilot as required by EASA in addition to further information supplied by manufacturer.

This manual must always be present on board the aircraft.

The aircraft is to be operated in compliance with information and limitations contained herein.

RECORD OF REVISIONS

Any revisions to the present Manual, except actual weighing data, must be recorded in the following table and, in case of approved Sections, endorsed by the responsible airworthiness authority.

New or amended text in the revised pages will be indicated by a black vertical line in the left-hand margin; Revision No. and date will be shown on the left-hand side of the page.

RECORD OF REVISIONS

Revision No.	Affected sections	Affected pages	Date	Approval EASA/DOA
1	6	10 to 14	25/02/2015	DOA
	7	14,16	25/02/2015	DOA
	9	22,24	25/02/2015	DOA
	9	25 to 28	25/02/2015	DOA
2	1	6	16/06/2015	DOA
	2	4,5,7,11	16/06/2015	EASA
	4	8,9	16/06/2015	EASA
	7	12,14,16	16/06/2015	DOA
	9	29 thru 32	16/06/2015	DOA
3	0	All	09/09/2016	DOA
	6	10 thru 13	09/09/2016	DOA
4	0	All	15/07/2019	DOA
	6	11 thru 13	15/07/2019	DOA

INTENTIONALLY LEFT BLANCK

LIST OF EFFECTIVE PAGES

Section	Revision
Section 0	<i>Rev 4</i>
Section 1	<i>Rev 2</i>
Section 2	<i>Rev 2</i>
Section 3	<i>Rev 0</i>
Section 4	<i>Rev 2</i>
Section 5	<i>Rev 0</i>
Section 6	<i>Rev 4</i>
Section 7	<i>Rev 2</i>
Section 8	<i>Rev 0</i>
Section 9	<i>Rev 2</i>

TABLE OF CONTENTS

General	Section 1
Limitations	Section 2*
Emergency procedures	Section 3*
Normal procedures	Section 4*
Performance	Section 5**
Weight & Balance / Equipment list	Section 6
Aircraft and Systems description	Section 7
Aircraft handling, servicing and maintenance	Section 8
Supplements	Section 9*

* Section approved by EASA

** Section partially approved by EASA

Sections 2, 3, 4, 5 are approved by EASA: n° 10030344 on 11.06.2010

Section 9 (supp.1) is approved by EASA: n° 2004-1787 on 02.03.2004

Section 9 (supp. 2) is approved by EASA: n° 2004-6324 on 17.06.2004

SECTION 1**GENERAL****TABLE OF CONTENTS**

INTRODUCTION	2
CERTIFICATION BASIS	2
WARNINGS - CAUTIONS - NOTES	2
THREE-VIEW DRAWING	3
DESCRIPTIVE DATA	4
CONTROL SURFACES TRAVEL LIMITS	4
ENGINE.....	5
PROPELLER	5
FUEL	6
OIL SYSTEM	6
COOLING.....	6
MAXIMUM CERTIFIED WEIGHTS	7
STANDARD WEIGHTS	7
SPECIFIC LOADINGS	7
ABBREVIATIONS AND TERMINOLOGY	8
UNIT CONVERSION CHART	11

INTRODUCTION

The P92-JS is a twin seat single engine aircraft with a strut-braced rectangular high wing, fixed main landing gear and steerable nosewheel.

This Flight Manual has been prepared to provide pilots and instructors with information for the safe and efficient operation of this aircraft.

This Flight Manual contains 9 sections. Section 1 provides basic data and information of general interest. It also contains definitions and explanations of symbols, abbreviations and commonly used terminology.

CERTIFICATION BASIS

Aircraft

This type of aircraft has been approved by EASA/ENAC in accordance with JAR-VLA of April 26 1990 with amendments 91/1 and 92/1.

Noise Certification Basis

JAR-36 Sub. C Issue: 23 May 1997 ICAO/Annex 16 Chap.10 issue 1993

WARNINGS - CAUTIONS - NOTES

The following definitions apply to warnings, cautions and notes used in the Flight Manual.

WARNING

Means that the non-observation of the corresponding procedure leads to an immediate or important degradation of the flight safety.

CAUTION

Means that the non-observation of the corresponding procedure leads to a minor or to a more or less long term degradation of the flight safety.

NOTE

Draws the attention to any special item not directly related to safety but which is important or unusual.

THREE-VIEW DRAWING

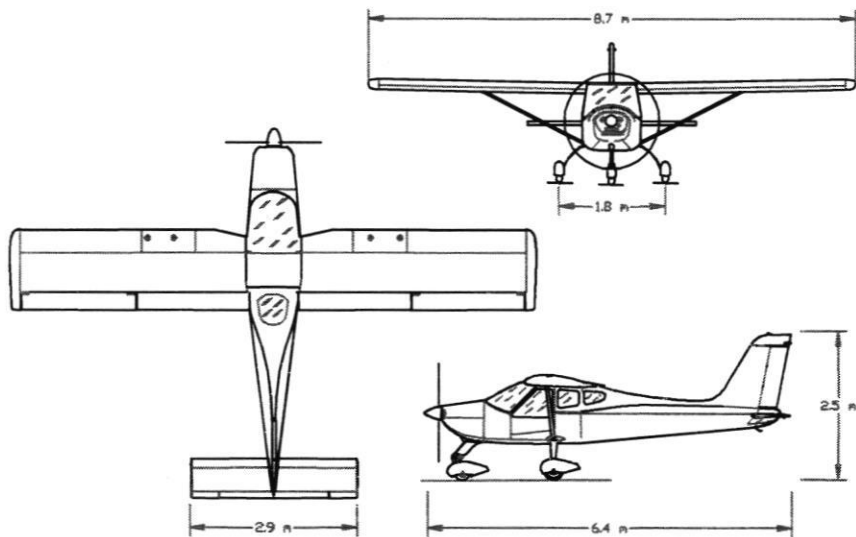

NOTE

- Dimensions shown refer to aircraft weight of 550kg (and 600 kg) and normal operating tire pressure.
- Propeller ground clearance 320mm
- Propeller ground clearance with deflated front tire and nosewheel shock absorber compressed by 102mm
- Minimum ground steering radius 5.5m

DESCRIPTIVE DATA
WING

	For 550 kg MTOW	For 600 kg MTOW
--	--------------------	--------------------

Wing span:	8.7 m	8.7 m
Wing chord	1.4 m	1.4 m
Wing surface	12 m ²	12 m ²
Wing loading	45.8 kg/m ²	50.0 kg/m ²
Aspect ratio	6.31	6.31
Taper ratio	1.0	1.0
Dihedral	1.5°	1.5°

FUSELAGE

Overall length	6.400 m	6.400 m
Overall width	1.100 m	1.100 m
Overall height	2.500 m	2.500 m

EMPENNAGE

Stabilator span	2.900 m	2.900 m
Vertical tail span	1.230 m	1.230 m

LANDING GEAR

Wheel track:	1.800 m	1.800 m
Wheel base:	1.600 m	1.600 m
Main gear tires: Air Trac;	5.00-5	5.00-5
Cleveland wheel hub and brakes kit:	199-102	199-102
Nose gear tire: Sava	4.00-6	4.00-6

CONTROL SURFACES TRAVEL LIMITS

Ailerons	Up 20° down 15° ± 2°
Stabilator	Up 18° down 3° ± 1°
Trim-Tab	2°; 12° ± 1°
Rudder	RH 25° LH 25° ± 1°
Flaps	0° -38° ± 1°

ENGINE

Manufacturer:	Bombardier-Rotax GmbH
Model	912 S2
Certification basis	FAR 33 Amendment 15
Austrian Type-Certification No.	n° TW 9-ACG of 27 Nov. 1998
Type:	4 cylinder horizontally-opposed twins with overall displacement of 1352 c.c., mixed cooling, (water-cooled heads and air-cooled cylinders), twin carburetors, integrated reduction gear with torque damper.
Maximum power:	73.5 kW (98.6 hp) @ 5800 rpm (<i>max. 5 min.</i>)
(<i>engine's rpm</i>)	69.0 kW (92.5 hp) @ 5500 rpm (<i>continuous</i>)

PROPELLER

Manufacturer:	HOFFMANN Propeller
Certification basis:	CAR Part 14
Type-Certification No.:	SO/E 30 of 10/12/1999
Model:	HO17GHM A 174 177C
Number of blades:	2
Diameter:	1740 mm (no reduction permitted)
Type:	Fixed pitch - wood

FUEL

Fuel grade:	<ul style="list-style-type: none">• EN 228 Premium• EN 228 Premium plus• AVGAS 100LL (see <i>Section 2.9</i>)
Fuel tanks:	2 wing tanks integrated within the wing's leading edge with fuel strainer located in engine cowling.
Capacity of each wing tank	35 liters (<i>optional 45 liters</i>)
Total capacity:	70 liters (<i>optional 90 liters</i>)
Total usable fuel	66.8 liters. (<i>86.8 liters</i>)

OIL SYSTEM

Oil system type:	Forced, with external oil reservoir
Oil:	Automotive grade API "SF" or "SG" type oil preferably synthetic or semi-synthetic
Oil Capacity:	3.0 liters

COOLING

Cooling system:	Mixed air and liquid pressurized closed circuit system
Coolant:	Antifreeze and water liquid mixture
Capacity	3 liters

MAXIMUM CERTIFIED WEIGHTS

Maximum take-off weight:	550 kg	600 kg
Maximum landing weight:	550 kg	600 kg
Maximum baggage weight	20 kg	20 kg

STANDARD WEIGHTS

Standard Empty Weight	325 kg	325 kg
Maximum Useful Load	225 kg	275 kg

SPECIFIC LOADINGS

Wing Loading	45.8 kg/m ²	50 kg/m ²
Power Loading	5.6 kg/hp	6.1 kg/hp

ABBREVIATIONS AND TERMINOLOGY

GENERAL AIRSPEED TERMINOLOGY AND SYMBOLS

KCAS	<u>Knots Calibrated Airspeed</u> is indicated airspeed corrected for position and instrument error and expressed in knots.
IAS	<u>Knots Indicated Airspeed</u> is the speed shown on the airspeed indicator and expressed in knots.
KTAS	<u>Knots True Airspeed</u> is the airspeed expressed in knots relative to undisturbed air which is KCAS corrected for altitude and temperature.
V _{FE}	<u>Maximum Flap Extended Speed</u> is the highest speed permissible with wing flaps in a prescribed extended position.
V _{NO}	<u>Maximum Structural Cruising Speed</u> is the speed that should not be exceeded except in smooth air, then only with caution.
V _{NE}	<u>Never Exceed Speed</u> is the speed limit that may not be exceeded at any time.
V _S	<u>Stalling Speed.</u>
V _{S0}	<u>Stalling speed in landing configuration</u>
V _{S1}	<u>Stalling speed in clean configuration (flap 0°)</u>
V _X	<u>Best Angle-of-Climb Speed</u> is the speed which results in the greatest gain of altitude in a given horizontal distance.
V _Y	<u>Best Rate-of-Climb Speed</u> is the speed which results in the greatest gain in altitude in a given time.
V _r	<u>Rotation speed:</u> is the speed at which the aircraft rotates about the pitch axis during takeoff
V _{LO}	<u>Lift off speed:</u> is the speed at which the aircraft generally lifts off from the ground.
V _{obs}	<u>Obstacle speed:</u> is the speed at which the aircraft flies over a 15m obstacle during takeoff or landing

METEOROLOGICAL TERMINOLOGY

- OAT** Outside Air Temperature is the free air static temperature expressed in degrees Celsius (°C).
- T_S** Standard Temperature is 15°C at sea level pressure altitude and decreased by 2°C for each 1000 ft of altitude.
- H_P** Pressure Altitude is the altitude read from an altimeter when the barometric subscale has been set to 1013 mb.

ENGINE POWER TERMINOLOGY

- RPM** Revolutions Per Minute: is the number of revolutions per minute of the propeller, multiplied by 2.4286 yields engine RPM.

AIRPLANE PERFORMANCE AND FLIGHT PLANNING TERMINOLOGY

- Crosswind Velocity* is the velocity of the crosswind component for which adequate control of the airplane during takeoff and landing is guaranteed.
- Usable fuel* is the fuel available for flight planning.
- Unusable fuel* is the quantity of fuel that cannot be safely used in flight..
- g* is the acceleration of gravity.
- TOR* is the takeoff distance measured from actual start to wheel liftoff point
- TOD* is total takeoff distance measured from start to 15m obstacle clearing
- GR* is the distance measured during landing from actual touchdown to stop point
- LD* is the distance measured during landing, from 15m obstacle clearing to actual stop.
- S/R* is specific range, that is, the distance (in nautical miles) which can be expected at a specific power setting and/or flight configuration per kilo of fuel used.

**WEIGHT AND BALANCE TERMINOLOGY**

- Datum* is an imaginary vertical plane from which all horizontal distances are measured for balance purposes.
- Arm* is the horizontal distance from the reference datum to the center of gravity (C.G.) of an item.
- Moment* is the product of the weight of an item multiplied by its arm.
- C. G.* Center of Gravity is the point at which the airplane, or equipment, would balance if suspended. Its distance from the reference datum is found by dividing the total moment by the total weight of the airplane.
- Standard Empty Weight* Standard Empty Weight is the weight of a standard airplane, including unusable fuel, full operating fuels and full engine oil.
- Basic Empty Weight* is the standard empty weight plus the weight of optional equipment.
- Useful Load* is the difference between takeoff weight and the basic empty weight.
- Maximum Weight* is the maximum certified weight of the aircraft.
- Maximum Takeoff Weight* is the maximum weight approved for the start of the takeoff run.
- Maximum Landing Weight* is the maximum weight approved for the landing touch down.
- Tare* is the weight of chocks, blocks, stands, etc. used when weighing an airplane, and is included in the scale readings. Tare is deducted from the scale reading to obtain the actual (net) airplane weight.

UNIT CONVERSION CHART

MULTIPLYING		BY →	YIELDS	
TEMPERATURE				
Fahrenheit	[°F]	$\frac{5}{9} \cdot (F - 32)$	Celsius	[°C]
Celsius	[°C]	$(\frac{9}{5} \cdot C) + 32$	Fahrenheit	[°F]
FORCES				
Kilograms	[kg]	2.205	Pounds	[lbs]
Pounds	[lbs]	0.4536	Kilograms	[kg]
SPEED				
Meters per second	[m/s]	196.86	Feet per minute	[ft/min]
Feet per minute	[ft/min]	0.00508	Meters per second.	[m/s]
Knots	[kts]	1.853	Kilometers / hour	[km/h]
Kilometers / hour	[km/h]	0.5396	Knots	[kts]
PRESSURE				
Atmosphere	[atm]	14.7	Pounds / sq. in	[psi]
Pounds / sq. in	[psi]	0.068	Atmosphere	[atm]
LENGTH				
Kilometers	[km]	0.5396	Nautical miles	[nm]
Nautical miles	[nm]	1.853	Kilometers	[km]
Meters	[m]	3.281	Feet	[ft]
Feet	[ft]	0.3048	Meters	[m]
Centimeters	[cm]	0.3937	Inches	[in]
Inches	[in]	2.540	Centimeters	[cm]
VOLUME				
Liters	[l]	0.2642	U.S. Gallons	[US Gal]
U.S. Gallons	[US Gal]	3.785	Liters	[l]
AREA				
Square meters	[m ²]	10.76	Square feet	[sq ft]
Square feet	[sq ft]	0.0929	Square meters	[m ²]

INTENTIONALLY LEFT BLANK

SECTION 2

LIMITATIONS

TABLE OF CONTENTS

INTRODUCTION	2
AIRSPED LIMITATIONS	2
AIRSPED INDICATOR MARKINGS	3
POWERPLANT LIMITATIONS	4
PROPELLER	6
POWERPLANT INSTRUMENT MARKINGS	7
OTHER INSTRUMENT MARKINGS	7
WEIGHTS	8
CENTER OF GRAVITY RANGE	8
APPROVED MANEUVERS	9
MANEUVERING LOAD FACTOR LIMITS	9
FLIGHT CREW	10
KINDS OF OPERATION	10
FUEL	10
MAXIMUM PASSENGER SEATING	11
CROSSWIND LIMITATIONS	11
LIMITATION PLACARDS	11

INTRODUCTION

Section 2 includes operating limitations, instrument markings, and basic placards necessary for safe operation of the P92-JS, its engine, standard systems and standard equipment.

NOTE

Refer to section 9 for possible variations to:

AIRSPPEED LIMITATIONS

Airspeed limitations and their operational significance are shown below:

S P E E D		550 kg MTOW		600 kg MTOW		REMARKS
		KIAS	KCAS	KIAS	KCAS	
V _{NE}	Never exceed speed	134	128	141	135	Never exceed this speed in any operation.
V _{NO}	Maximum Structural Cruising Speed	106	102	110	106	Never exceed this speed unless in smooth air, and then only with caution.
V _A	Maneuvering speed	93	90	97	94	Do not make full or abrupt control movements above this speed as this may cause stress in excess of limit load factor
V _{FE}	Maximum flap extended speed	68	66	71	69	Never exceed this speed for any given flap setting.

AIRSPPEED INDICATOR MARKINGS

Airspeed indicator markings and their color code are explained in the following table

Refer to section 9 of this Flight Manual for operational limitations for aircraft fitted with optional equipment.

MARKING	550 kg MTOW	600 kg MTOW	SIGNIFICANCE
	KIAS		
White arc	43 ^a - 68	41 - 71	Positive Flap Operating Range (lower limit is V_{SO} at maximum weight and upper limit is maximum speed permissible with flaps extension to maximum positive)
Green arc	48 ^a - 106	46 - 110	Normal Operating Range (lower limit is V_{S1} at maximum weight and most forward c.g. with flaps retracted and upper limit is maximum structural speed V_{NO}).
Yellow arc	106 - 134	110- 141	Maneuvers must be conducted with caution and only in smooth air.
Red line	134	141	Maximum speed for all operations.

CAUTION

For P92-JS with MTOW = 550kg the low limit of the white arc is $1.1 V_{SO}$ while the low limit of the green arc is $1.1V_{S1}$

POWERPLANT LIMITATIONS

The following table lists operating limitations for aircraft installed engine:

ENGINE MANUFACTURER: Bombardier Rotax GmbH.

ENGINE MODEL: 912 S2

MAXIMUM POWER: (see table below)

	Max Power kW (<i>hp</i>)	Max RPM. RPM prop (<i>eng.</i>)	Time max. (min.)
Maximum	73.5 (98.6)	2388 (5800)	5
Max cont.	69 (92.5)	2265 (5500)	-

NOTE

The static rpm range at full throttle (carburetors heat: Off) is 2100 ± 100 prop. rpm.

TEMPERATURES:

Max cylinder heads*	135° C
Max coolant temperature	120° C
Max Oil:	130° C
Min Oil	50° C

- * *applicable for Engines up to serial no. 4924543 (included) and repaired engine which doesn't change the cylinder head n°3 with new one (part no. 413195)*

OIL PRESSURE:

Min	0.8 bar
Max	5 bar

WARNING**ENGINE START. OPER. TEMP:**

OAT Min	-25° C
OAT Max	+50° C

Admissible pressure for cold start is 7 bar maximum for short periods.

FUEL PRESSURE:Min	2.2 psi
Max	5.8 psi
Max*	7.2 psi

*only applicable for fuel pump part no. 893110 and 893114

VISCOSITY

Use viscosity grade oil as specified in the following table:

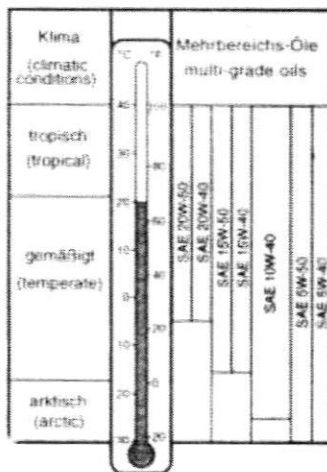

WARNING

Use of Aviation Grade Oil with or without additives is not permitted

COOLANT:

Mixture: 80% concentrated antifreeze (e.g. BASF Glysantin Anticorrosion or equivalent) with anticorrosion additive and 20% demineralized water.

PROPELLER

MANUFACTURER: HOFFMANN Propeller

MODEL: HO17GHM-174 177C or HO17GHM A 174 177C

PROPELLER TYPE: Wood twin blade fixed pitch

DIAMETER: 1740 mm (no reduction permitted)

POWERPLANT INSTRUMENT MARKINGS

Powerplant instrument markings and their color code significance are shown below:

INSTRUMENT		RED LINE Minimum limit	GREEN ARC Normal operating	YELLOW ARC Caution	RED LINE Maximum limit
Prop tach	RPM	-----	580-2265	2265-2388	2388
Oil Temp.	°C	50	90-110	50 - 90 110-130	130
Cylinder heads temp ⁽⁴⁾	°C	-----	0 - 135	-----	135
Coolant temp.	°C		0 - 120		120
Oil pressure	bar	0.8	2 - 5	0.8 - 2 5 - 7 ⁽¹⁾	7
Fuel Press.	psi	2.2	2.2-5.8 or 7.26 ⁽³⁾	----	5.8 or 7.26 ⁽³⁾
Fuel quantity	liters	----- ⁽²⁾	----	----	----

OTHER INSTRUMENT MARKINGS

INSTRUMENT	RED LINE Minimum limit	GREEN ARC Normal operating	YELLOW ARC Caution	RED LINE Maximum limit
Suction gage	4 in. Hg	4,5 - 5.5 in. Hg.	-----	-----
Voltmeter	10 Volt	12 - 14 Volt	-----	-----

1 Admissible pressure for cold start is 7 bar maximum for short periods.

2 - Unusable fuel for each tank is 1.6 litres

3 - When fuel pump part no. 893110 and 893114 is installed

4 - Applicable for Engines up to serial no. 4924543(included) and repaired engine which doesn't change the cylinder head n°3 with new one (part no. 413195)

WEIGHTS

	550 kg MTOW	600 kg MTOW
Maximum takeoff weight	550 kg	600 kg
Maximum landing weight	550 kg	600 kg
Maximum zero fuel weight	550 kg	600 kg
Maximum baggage weight (2.18 m from datum)	20 kg	20 kg

NOTE

Refer to section 6 for correct stowing and loading of baggage.

CENTER OF GRAVITY RANGE

Ref. for levelling	Cabin floor
Datum	Propeller support flange without spacer
Forward limit	1.727 m (23% MAC) aft of datum for all weights
Aft limit	1.769 m (26% MAC) aft of datum for all weights

WARNING

*It is the pilot's responsibility to insure that the airplane is properly loaded.
Refer to section 6 for appropriate instructions.*

APPROVED MANEUVERS

This aircraft is certified in the CS-VLA category.

CS-VLA applies to airplanes intended for non-aerobatic operation only. Non-aerobatic operation includes:

- Any maneuver pertaining to "normal" flight
- Stalls (except whip stalls)
- Lazy eights
- Chandelles
- Turns in which the angle of bank is not more than 60°

Acrobatic maneuvers, including spins, are not approved

Recommended entry speed for each approved maneuver is as follows:

MANEUVER	KIAS	
	550 kg MTOW	600 kg MTOW
Lazy eights	93	97
Chandelles	93	97
Steep turns max 60°	93	97
Stalls	Slow Deceleration (1 Kts/sec.) Slow Deceleration (1 Kts/sec.)	

MANEUVERING LOAD FACTOR LIMITS

Maneuvering load factors are as follows:

FLAPS

0°	+3.8	- 1.9
38°	+1.9	0

FLIGHT CREW

Minimum crew for flight is one pilot seated on the left side.

KINDS OF OPERATION

The airplane, in standard configuration, is approved only for day VFR operation with terrain visual contact. Minimum equipment required is as follows:

- Altimeter
- Airspeed Indicator
- Heading Indicator
- Fuel Gage
- Oil Pressure Indicator
- Oil Temp. Indicator
- Cylinder Heads Temp. Indicator
- Outside Air Temp. indicator
- Tachometer
- Chronometer
- First Aid Kit
- Hand-held fire extinguisher

For further standard equipment refer to section 6.

Flight into expected and/or known icing conditions is prohibited.

FUEL

TWO TANKS: 35 liters each (*45 liters optional*)

TOTAL FUEL CAPACITY: 70 liters (*90 liters*)

USABLE FUEL: 66.8 liters (*86.8 liters*)

UNUSABLE FUEL: 3.2 liters (*3.2 liters*)

During all phases of flight engine fuel feed must be supplied by both tanks. Compensate uneven fuel tank levels by acting on fuel taps located in cabin.

APPROVED FUEL

- EN 228 Premium
- EN 228 Premium plus
- AVGAS 100LL (see *Warning* below)

WARNING

Prolonged use of Aviation Fuel Avgas 100LL results in greater wear of valve seats and greater combustion deposits inside cylinders due to higher lead content. It is therefore suggested to avoid using this type of fuel unless strictly necessary.

MAXIMUM PASSENGER SEATING

Only one passenger is allowed on board this aircraft.

CROSSWIND LIMITATIONS

Maximum allowed crosswind component is 15 Kts (refer to section 5 for further details).

LIMITATION PLACARDS

The following limitation placards must be placed in plain view on the aircraft. Near the airspeed indicator a placard will state the following:

MANEUVERING SPEED $V_A=93$ KIAS

For 550 kg MTOW

MANEUVERING SPEED $V_A=97$ KIAS

For 600 kg MTOW

On the Middle panel of the instrument panel a placard will state the following:

THIS AIRPLANE IS CLASSIFIED AS A VERY LIGHT AIRPLANE APPROVED FOR DAY VFR ONLY, IN NON-ICING CONDITIONS. ALL AEROBATIC MANEUVERS INCLUDING INTENTIONAL SPIN ARE PROHIBITED. SEE FLIGHT MANUAL FOR OTHER LIMITATIONS.

NO SMOKING

Near baggage compartment a placard will state the following:

FASTEN TIE-DOWN NET
MAXIMUM WEIGHT 20 kg
MAX. PRESS 12.5 Kg/dm²

SECTION 3

EMERGENCY PROCEDURES

TABLE OF CONTENTS

INTRODUCTION	2
ENGINE FAILURES	2
AIR START	4
SMOKE AND FIRE	4
GLIDE	5
LANDING EMERGENCIES	5
RECOVERY FROM UNINTENTIONAL SPIN	6
OTHER EMERGENCIES	7

INTRODUCTION

Section 3 includes checklists and detailed procedures to be used in the event of emergencies. Emergencies caused by a malfunction of the aircraft or engine are extremely rare if appropriate maintenance and pre-flight inspections are carried out.

In case of emergency, suggestions of the present section should be considered and applied as necessary to correct the problem.

Before operating the aircraft, the pilot should become thoroughly familiar with the present manual and, in particular, with the present section. Further, a continued and appropriate training should be provided.

AIRSPEEDS FOR SAFE OPERATION IN EMERGENCY SITUATIONS - IAS

	550 kg MTOW	600 kg MTOW
Engine failure after takeoff	60 Kts	60 Kts
Engine failure during flight	66 Kts	69 Kts
Manoeuvring speed	93 Kts	97 Kts
Maximum glide	66 Kts	69 Kts

ENGINE FAILURES

Should an emergency arise, the basic guidelines described in this section should be considered and applied as necessary to correct the problem.

ENGINE FAILURE DURING TAKEOFF RUN

1. Throttle: *idle* (fully out)
2. Brakes: *apply as needed*
3. Magnetos: *OFF*.
4. Flap: *retract*
5. Generator switch and Master switch: *OFF*.
6. Fuel shutoff valves: *OFF*
7. Electric fuel pump: *OFF*
8. Inform TWR

ENGINE FAILURE IMMEDIATELY AFTER TAKEOFF

1. Speed 60 KIAS
2. Locate landing area
3. Throttle: *idle* (fully out)
4. Fuel shutoff valves: *OFF*.
5. Electric fuel pump: *OFF*
6. Magnetos *OFF*.
7. Flaps: *as needed*.
8. Generator switch and Master switch: *OFF*.
9. Inform TWR

ENGINE FAILURE DURING FLIGHT

IRREGULAR ENGINE RPM

1. Throttle: *check position and adjustment wheel*
2. Carb heat: *ON*
3. Electric fuel pump: *ON*
4. Fuel shutoff valves: *both ON*
5. If engine RPMs remain irregular land as soon as possible at closest airport.

LOW FUEL PRESSURE

If the fuel pressure indicator falls below the **2.2** psi limit, it is necessary to apply the following procedure:

1. Electric fuel pump: *ON*
2. Fuel shutoff valves: *both ON*
3. Land at closest airport

LOW OIL PRESSURE

1. Check oil temperature:
If stable within green arc: Land as soon as possible at closest airport
If increasing:
2. Reduce engine throttle to 70 KIAS
3. Land as soon as possible and be alert for impending engine fault and consequent emergency landing.

AIR START

1. Altitude: *preferably below 4000 ft*
2. Carb heat: *ON*
3. Fuel shutoff valves: *both ON*
4. Electric fuel pump: *ON*
5. Throttle: *middle position*
6. Generator switch and Master switch: *ON*.
7. Magnetos: *BOTH*.
8. Ignition key to *START*
9. If engine restarts, keep an eye on instrument readings and land as soon as possible, otherwise see procedure for: *Forced landing*

SMOKE AND FIRE**ENGINE FIRE WHILE PARKED OR DURING TAKEOFF**

1. Fuel shutoff valves: *OFF*
2. Electric fuel pump: *OFF*
3. Cabin heat: *OFF*
4. Abort takeoff if possible.
5. If engine is running, use up remaining fuel in carburetors.
6. Magnetos: *OFF*.
7. Master switch: *OFF*.
8. Generator switch: *OFF*.
9. Warn bystanders to clear the area as fast as possible.
10. Without removing the engine cowling use a CO₂ or a powder fire extinguisher to put out flames directing spray towards cowling's air intakes.

WARNING

DO NOT USE WATER to put out fire and do not open engine cowling until absolutely confident that fire is extinguished.

ENGINE FIRE DURING FLIGHT

1. Fuel shutoff valves: *OFF*.
2. Electric fuel pump: *OFF*
3. Cabin heat: *OFF*
4. Throttle: *all in*.
5. Magnetos: *OFF*.
6. Do not attempt air start.
7. Flaps as necessary.
8. Carry out emergency procedure for *forced landing*.

CABIN FIRE DURING FLIGHT

1. Master switch: *OFF*
2. Cabin heat: *OFF*
3. Door vents: *open*
4. Direct fire extinguisher towards flame base
5. Carry out emergency procedure for *forced landing*

GLIDE

1. Flaps: *retract*
2. Speed at: **600 kg 69KIAS**
550 kg 66KIAS
450 kg 60KIAS
3. Glide ratio is **12.2** therefore with 1000ft elevation it is possible to cover ~3.8 km (~2 *nautical miles*) in zero wind conditions.

LANDING EMERGENCIES

FORCED LANDING WITHOUT ENGINE POWER

1. Suggested airspeed 69 KIAS for 600kg MTOW, 66 KIAS for 550kg MTOW, 60 KIAS for 450kg.
2. Locate most suitable terrain for emergency landing, possibly upwind.
3. Fuel shutoff valves: *OFF*.
4. Electric fuel pump: *OFF*.
5. Magnetos: *OFF*.
6. Tighten safety belts, release door safety lock and unlatch doors.
7. Flaps: *full*
8. When certain to land, Generator switch and Master switch: *OFF*.
9. Touchdown at 42 KIAS

POWER-ON FORCED LANDING

1. Prompt descent slope.
2. Flaps as required.
3. Select terrain area most suitable for emergency landing and flyby checking for obstacles and wind direction.
4. Tighten safety belts, release door safety lock and unlatch doors.
5. Before touchdown: fuel shutoff valves: *OFF*.
6. Electric fuel pump: *OFF*
7. Carb heat: *OFF*
8. Flaps: *full*
9. After touchdown: magnetos: *OFF*.
10. Generator switch and Master switch: *OFF*.

LANDING WITH A FLAT NOSE TIRE

1. Pre-landing checklist: *complete*
2. Flaps: *full*
3. Land and maintain aircraft *NOSE HIGH* attitude as long as possible. After touchdown.

LANDING WITH A FLAT MAIN TIRE

1. Pre-landing checklist: *complete*
2. Landing approach as usual.
3. Touchdown with *GOOD TIRE FIRST* and hold aircraft off flat tire as long as possible.

RECOVERY FROM UNINTENTIONAL SPIN

Should an unintentional spin occur, the following recovery procedure should be used:

1. Adjust throttle to idle (full outward position)
2. Apply and hold full rudder opposite to the direction of spin.
3. Move and hold stick forward until spin is halted.
4. Neutralize rudder
5. Make a smooth recovery by pulling the stick back gently averting speeds in excess of V_{NE} and maximum load factor.
6. Readjust throttle to restore engine power.

OTHER EMERGENCIES

UNINTENTIONAL FLIGHT INTO ICING CONDITIONS

1. Get away from icing conditions by changing altitude or direction of flight in order to reach an area with warmer external temperature.
2. Avoid possible freeze-up of control surfaces by recurrently moving them.
3. Carb heat: *ON*
4. Increase RPMs to avoid ice formation on propeller blades.
5. Cabin heat: *ON*

WARNING

In case of ice formation on wing leading edge, stall speed may increase.

CARBURETOR HEAT

AT TAKEOFF

At takeoff, given the unlikely possibility of ice formation at full throttle, carburetor heat is normally OFF.

IN FLIGHT

With external temperatures below 15° C, or on rainy days or with humid, cloudy, hazy or foggy conditions or whenever a power loss is detected, turn carb heat to ON until engine power is back to normal.

ELECTRIC POWER SYSTEM MALFUNCTION

Electric power supply system malfunctions may be avoided by carrying out inspections as scheduled and prescribed in the Service Manual. Causes for malfunctions are hard to establish but, in any case, problems of this nature must be dealt with immediately. The following may occur:

GENERATOR LIGHT ILLUMINATES

Generator light may illuminate for a faulty alternator or when voltage is above 16V, in this case the overvoltage sensor automatically shuts down the alternator.

In both cases proceed as follows:

1. Generator switch and master switch: *OFF*.
2. Generator switch and master switch: *ON*.

If the problem no longer persists, normal alternator charging will resume and the warning light will turn off proving voltage surcharge was temporary; no further action is required.

If light remains illuminated, a generator malfunction is confirmed. In this case, set Generator switch to *OFF* and continue flight on battery power alone; the battery is capable of supplying the electrical system for about 26 min. with normal flight loads including operation of: com/nav. flap and trim.

TRIM SYSTEM FAILURE

LOCKED CONTROL

In case the trim control should not respond, act as follows:

1. Check switch for correct position
2. Adjust speed to control aircraft without excessive stick force
3. Land aircraft as soon as possible.

RUNAWAY

If trim position indicator reads displacement without pilot's action on trim control, follow procedure below:

1. Trim power switch *OFF*
2. Adjust speed to control aircraft without excessive stick force
3. Land aircraft as soon as possible.

SECTION 4
NORMAL PROCEDURES

TABLE OF CONTENTS

INTRODUCTION.....	2
RIGGING AND DERIGGING ENGINE COWLING.....	2
PRE-FLIGHT INSPECTIONS.....	3
CHECKLISTS.....	6

INTRODUCTION

Section 4 contains checklists and the procedures for the conduct of normal operation.

RIGGING AND DERIGGING ENGINE COWLING
UPPER COWLING:

- I. Parking brake ON.
- II. Fuel shutoff valves OFF.
- III. Generator switch OFF. Master switch OFF, Magnetos OFF.
- IV. Unlatch all four butterfly Cam-locks mounted on the cowling by rotating them 90° counterclockwise while slightly pushing inwards.
- V. Remove engine cowling paying attention to propeller shaft passing through nose.
- VI. To assemble: rest cowling horizontal insuring proper fitting of nose base reference pins.
- VII. Secure latches by applying light pressure, check for proper assembly and fasten Cam-locks.

WARNING

Butterfly Cam-locks are locked when tabs are horizontal and open when tabs are vertical. Verify tab is below latch upon closing.

LOWER COWLING

- I. After disassembling upper cowling, bring propeller to horizontal position.
- II. Using a standard screwdriver, press and rotate 90° the two Cam-locks positioned on lower cowling by the firewall.
- III. Pull out the first hinge pin positioned on the side of the firewall, then, while holding cowling, pull out second hinge pin; remove cowling with downward motion.
- IV. For installation follow reverse procedure.

PRE-FLIGHT INSPECTIONS

Before each flight, it is necessary to carry out a complete inspection of the aircraft starting with an external inspection followed by an internal inspection as hereby detailed.

CABIN INSPECTION

- A Flight Manual: check that a copy is on board
- B Weight and balance: check if within limits
- C Safety belts used to lock controls: free
- D Flight controls: activate flight controls to insure unhindered movement of control rods and surfaces
- E Parking brake: engage
- F Throttle: adjust friction lock
- G Magnetos: OFF
- H Master switch: ON
- I Voltmeter: check (10-12 V); Ammeter check (red).
- J Generator switch: ON, check generator switch is illuminated
- K Fuel pump: ON, check light ON, audible sound and correct operation of fuel pressure indicator.
- L Avionics switch: ON, check operation; when finished, reposition switch to OFF
- M Flaps control: activate control to full extension checking travel limits and instrument indication.
- N Trim control: activate control to full scale checking travel limits and instrument indication
- O Acoustic stall warning: check operation
- P Navigation lights and strobe-light: check operation
- Q Landing light: check operation
- R Generator switch: OFF
- S Master switch: OFF
- T Fuel level: check level on the basis of flight plan
- U Baggage: check for proper stowage with tie-down net.

WARNING

Fuel level indicated by the fuel quantity indicators (on the instrument panel) is only indicative. For flight safety, pilot should verify actual fuel quantity embarked before takeoff.

EXTERNAL INSPECTION

To carry out the external inspection it will be necessary to follow the checklist below with the station order outlined in fig. 4-1.

WARNING

Visual inspection is defined as follows: check for defects, cracks, detachments, excessive play, unsafe or improper installation as well as for general condition. For control surfaces, visual inspection also involves additional check for freedom of movement and security.

- A Left hand fuel filler cap: check visually for desired fuel level and secure. Left tank vent: check for obstructions.

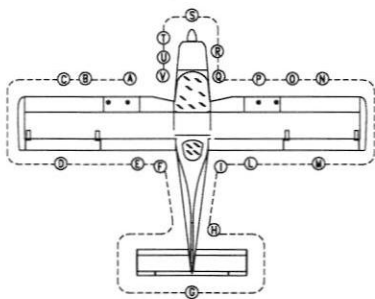
FIG 4-1

- B Remove protection cap and check pitot mounted on left strut is unobstructed, do not blow inside vents, place protection cap inside aircraft.

- C Left side leading edge and wing skin: visual inspection
- D Left aileron: visual inspection
- E Left flap and hinges: visual inspection
- F Left main landing gear: check inflation 14 psi (1.0 bar), tire condition, alignment, fuselage skin condition.
- G Horizontal tail and tab: visual inspection.
- H Vertical tail and rudder: visual inspection.
- I Right side main landing gear: check inflation 14 psi (1.0 bar), tire condition, alignment, fuselage skin condition.
- L Right flap and hinges: visual inspection.
- M Right aileron: visual inspection.
- N Right leading edge and wing skin: visual inspection.
- O Check freedom of movement of stall detector microswitch on right side leading edge, activate Master switch and check cabin acoustic warning signal is operative, deactivate Master switch.
- P Right side fuel filler cap: check visually for desired fuel level and secure. Right side tank vent: check for obstructions.
- Q Right side static port: check for obstructions, do not blow inside vents (read note).
- R Nose wheel strut and tire: check inflation 11 psi (0.8 bar), tire condition and condition of rubber shock absorber discs.
- S Propeller and spinner condition: check for nicks and security.
- T Open engine cowling and perform the following checklist:
 - I. Check no foreign objects are present.
 - II. Check the cooling circuit for losses, check coolant reservoir level, insure radiator honeycomb is unobstructed.
 - III. Check lubrication circuit for losses, check oil reservoir level, insure radiator honeycomb is unobstructed.
 - IV. Open both fuel shutoff valves, inspect fuel circuit for losses, check integrity of fireproof protection braids, drain circuit using a cup to collect fuel by opening the specific drainage valve located on the firewall, close shutoff fuel valves. Check for water or other contaminants.

Drainage operation must be carried out with aircraft parked on level surface.

- V. Check integrity of silent-block suspensions.
- VI. Check connection and integrity of air intake system, visually inspect that ram air intake is unobstructed.
- VII. Check that all parts are secure or safetied.
- U Close engine cowling.
- V Check left side static vent is unobstructed.
- Z Remove tow bar and chocks.

NOTE

Avoid blowing inside left strut mounted pitot and inside airspeed indicator system's static vents as this may damage instruments.

CHECKLISTS

BEFORE STARTING ENGINE (after preflight inspection)

- I. Flight planning, fuel consumption, refueling.
- II. Check correct aircraft loading and correct CG position (see section 6).
- III. Seat position and safety belts adjustment
- IV. Doors secured
- V. Parking brake ON.

CAUTION

Avionics general switch must be OFF during engine startup to avoid damage to avionics instrumentation.

STARTING ENGINE

- I. Circuit Breakers: check IN
- II. Master switch ON. Check Voltmeter and Ammeter
- III. Fuel shutoff valves: both ON.

- IX. Ignition key set to: START.
- X. Generator switch "ON" and check Ammeter "green".
- XI. Propeller rpm: 1000-1100 rpm
- XII. Choke OFF
- XIII. Check engine instruments
- XIV. Check oil pressure rise within 10 sec. (maximum cold value 7 bar)
- XV. Electric fuel pump: OFF
- XVI. Check fuel pressure
- XVII. Electric fuel pump: ON

BEFORE TAXIING

- I. Radio and utilities ON.
- II. Altimeter: reset.
- III. Navigation lights: as required
- IV. Request control tower O.K., parking brake OFF and taxi.

TAXIING

- I. Brakes: CHECK
- II. Flight instruments: CHECK

PRIOR TO TAKE-OFF

- I. Parking brake ON.
- II. Turn on navigation lights, strobe light, and landing light
- III. Check engine instruments:
 - Oil temperature 50-110 °.
 - Cylinder heads temperature max 135 ° or Coolant temperature max 120° (if Rotax SB912-066 is applicable on engine SN).
 - Oil pressure 2-5 bar.
 - Fuel pressure 2.2 – 5.8 psi or 7.2 psi (if fuel pump part no. 893110 and 893114 is installed)
- IV. Check ammeter to insure alternator is charging.
- V. Propeller at 1700 rpm and test Magnetos (speed drop with only one ignition circuit must not exceed 130 propeller's rpm).
- VI. Check fuel level indicators.
- VII. Flaps at 15° (takeoff)
- VIII. Stick free and zero trim
- IX. Seat belts fastened and doors secured.

TAKEOFF AND CLIMB

- I. TWR: OK for takeoff
- II. Check for clear final and wind on runway.
- III. Parking brake OFF,
- IV. Carburetor heat: OFF
- V. Taxi to line-up
- VI. Full throttle (approx. 2100 ± 100 propeller rpm)
- VII. Rotation speed Vr=47 Kts for 550 kg MTOW and Vr=48 Kts for 600kg MTOW.
- VIII. Rotation and takeoff

- IX. Slight braking to stop wheel spinning.
- X. Flaps retracted
- XI. Landing light OFF.
- XII. Trim adjustment
- XIII. Establish climb rate
- XIV. Electric fuel pump: OFF

CRUISE

- I. Reach cruising altitude
- II. Set power and engine rpm's for cruise.
- III. Check engine instruments
 - Oil temperature 90°-110 ° C.
 - Temperature cylinder heads 90° + 135 °C or Coolant temperature 90° ÷ 120°
 - Oil pressure 2 - 5 bar.
 - Fuel pressure 2.2 – 5.8 psi or 2.2 – 7.2 psi
- IV. Carburetor heat as needed, see paragraph on carb. heat in Section 3.

NOTE

Compensate unpredicted asymmetrical fuel consumption between left and right fuel tanks by closing appropriate fuel shutoff valve inside cabin.

BEFORE LANDING

- I. Contact TWR.
- II. Electric fuel pump ON
- III. Turn on landing light.
- IV. Check runway final and establish descent and approach to final.
- V. Extend flaps gradually to maximum deflection of 38°.
- VI. Optimal touchdown speed: 44Kts for 550kg MTOW and 45Kts for 600kg MTOW

BALKED LANDING

- I. Full throttle
- II. Flaps position: TO
- III. Speed: 60 KIAS (63KIAS) for 550kg MTOW (600kg)

NORMAL LANDING

- I. Land and taxi.
- II. Flaps to 0°.
- III. Parking brake ON.
- IV. Turn off landing, navigation and strobe lights.

ENGINE SHUT DOWN

- I. Keep engine running at 1200 rpm for about two minutes in order to reduce latent heat.
- II. Electric fuel pump: OFF
- III. Turn off all electrical utilities.
- IV. Set magnetos switch to OFF.
- V. Set Generator switch and Master switch to OFF.
- VI. Set both fuel shutoff valves to OFF.

POSTFLIGHT CHECK

- I. Insert hood over pitot tube on left side wing strut.
- II. Lock controls using seat belts.

INTENTIONALLY LEFT BLANK

SECTION 5

PERFORMANCE

TABLE OF CONTENTS

PERFORMANCE	2
INTRODUCTION	2
USE OF PERFORMANCE CHARTS.....	2
AIRSPEED INDICATOR SYSTEM CALIBRATION (<i>APPROVED DATA</i>)	3
STALL SPEED (<i>APPROVED DATA</i>)	5
CROSSWIND	6
TAKEOFF PERFORMANCE (<i>APPROVED DATA</i>).....	7
CLIMB PERFORMANCE.....	9
CRUISE	10
BALKED LANDING.....	12
LANDING DISTANCE (<i>Approved data</i>).....	13
CONSEQUENCES FROM RAIN AND INSECT.....	14
NOISE DATA.....	14

PERFORMANCE

INTRODUCTION

This section provides all necessary data for accurate and comprehensive planning of flight activity from takeoff to landing.

Data reported in graphs and/or tables were determined by using:

- “flight test data” with conditions as prescribed by JAR-VLA
- aircraft and engine in good condition
- average piloting techniques

Each graph or table was determined according to ICAO Standard Atmosphere (ISA - m.s.l.); evaluations of the impact on performance was carried out by theoretical means for:

- airspeed
- external temperature
- altitude
- weight
- type and condition of runway

Sections approved by ENAC are highlighted by the writing “*Approved data*” immediately following the paragraph.

USE OF PERFORMANCE CHARTS

Performance data is presented in tabular or graphical form to illustrate the effect of different variables such as altitude, temperature and weight. Given information is sufficient to plan journey with required precision and safety.

Additional information is provided for each table or graph.

AIRSPED INDICATOR SYSTEM CALIBRATION

(Approved data)

Graph shows calibrated airspeed V_{CAS} as a function of indicated airspeed V_{IAS} .

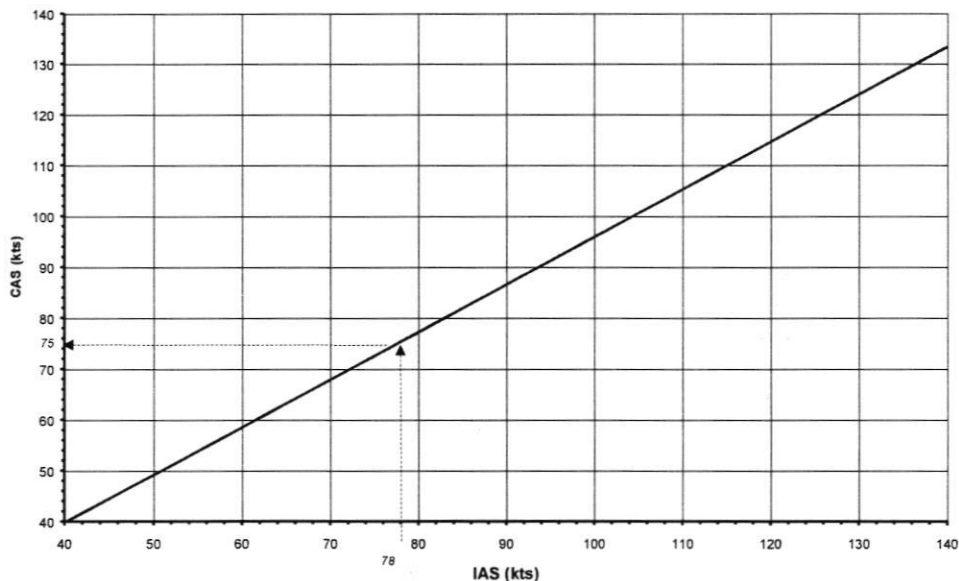

Fig. 5-1. CALIBRATED VS INDICATED AIRSPEED (BOTH MTOW)

⇒ Example:

Given

$$V_{IAS} = 78 \text{ Kts}$$

Find

$$V_{CAS} = 75 \text{ Kts}$$

NOTE

Indicated airspeed assumes 0 instrument error

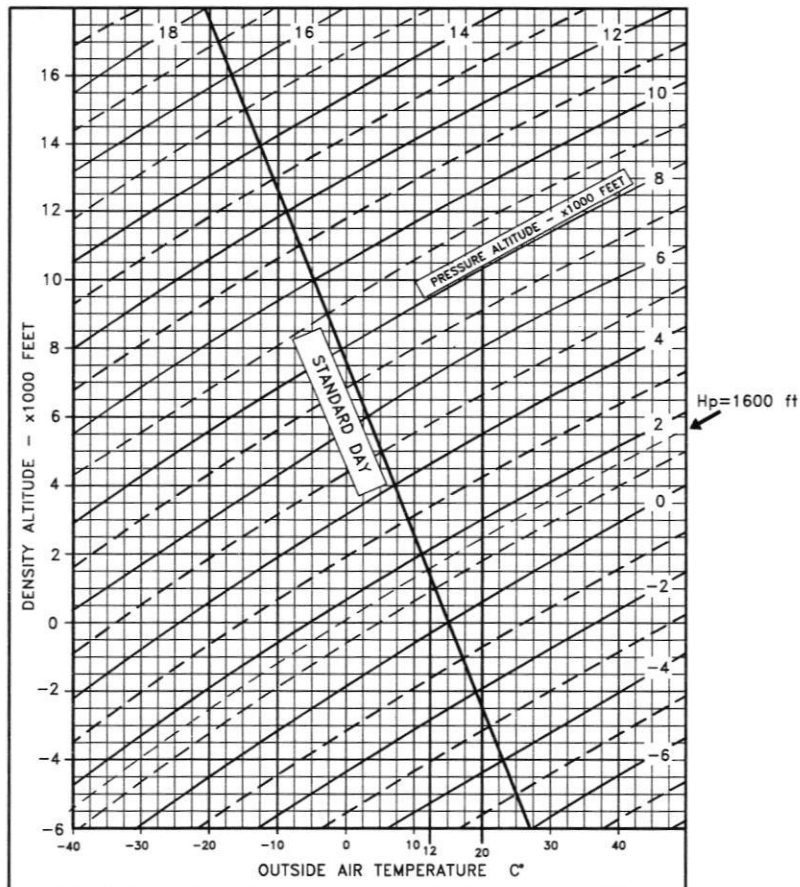

Fig. 5-2. ICAO CHART

⇒ *Example:*

Given

Temperature = 20°C

Pressure altitude = 1600 ft

Find

$T_s = 12^\circ$

STALL SPEED *(Approved data)*

CONDITIONS: - weight 550 kg
 - engine idle
 - no ground effect

FLAPS	LATERAL BANKING							
	0°		30°		45°		60°	
	KIAS	KCAS	KIAS	KCAS	KIAS	KCAS	KIAS	KCAS
0°	44	43	47	46	52	51	63	61
15°	42	41	45	44	50	49	60	58
38°	40	39	42	41	47	46	56	55

CONDITIONS: - weight 600 kg
 - engine idle
 - no ground effect

FLAPS	LATERAL BANKING							
	0°		30°		45°		60°	
	KIAS	KCAS	KIAS	KCAS	KIAS	KCAS	KIAS	KCAS
0°	46	45	49	48	54	53	66	64
15°	44	43	47	46	52	51	63	61
38°	41	40	44	43	49	48	58	56

NOTE

Altitude loss during conventional stall recovery as demonstrated during test flights is approximately 100 ft with banking under 30°.

CROSSWIND

Maximum demonstrated crosswind velocity is 15 Kts

⇒ Example:

Given

Wind direction = 30°
 Wind velocity = 20 Kts

Find

Headwind = 17.5 Kts
 Crosswind = 10 Kts

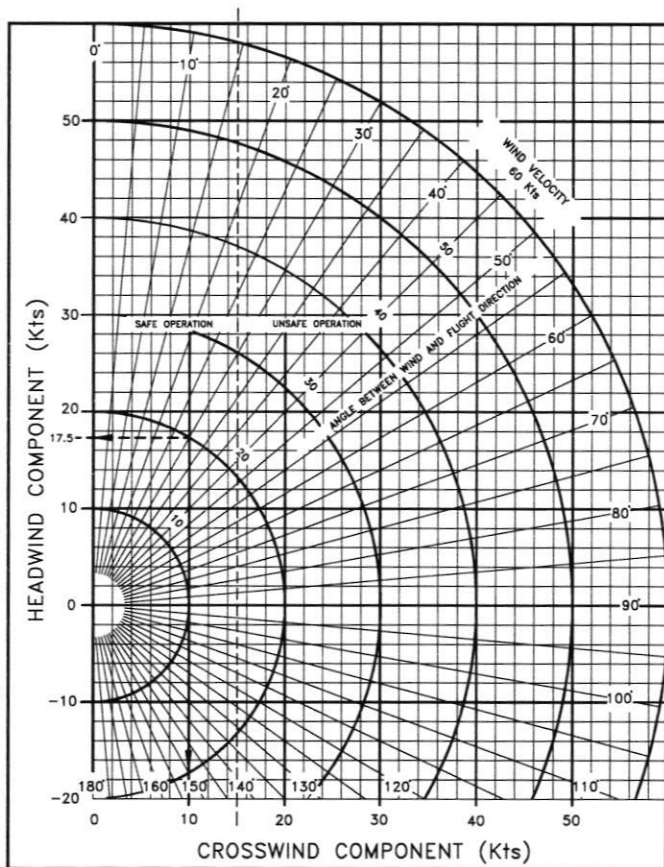

Fig. 5-3. CROSSWIND CHART

TAKEOFF PERFORMANCE (Approved data)

TAKEOFF DISTANCE

CONDITIONS:

- | | | |
|--------------------------------------|-----------------------|------------|
| - Flaps: 15° | MTOW=550kg | MTOW=600kg |
| - Engine: full throttle (see Sect.4) | - V_R = 47 KIAS | 48 KIAS |
| - Runway: dry, compact, grass | - V_{obs} = 56 KIAS | 58 KIAS |
| - Slope: 0° Wind: zero | - V_{LO} = 49 KIAS | 51 KIAS |
| - R/C \geq 200 ft/min | | |

NOTE

1. Decrease distances by 10% for each 10 Kts of headwind.
Increase distances by 20 % for each 10 Kts of tailwind
2. For dry and paved runway operation decrease ground run by 6 %

⇒ Example:

Given

O.A.T. = 15°C
Pressure-altitude = 2900 ft
MTOW = 600kg
Weight = 450 Kg

Find

TOD = 253m
TOR = 117 m

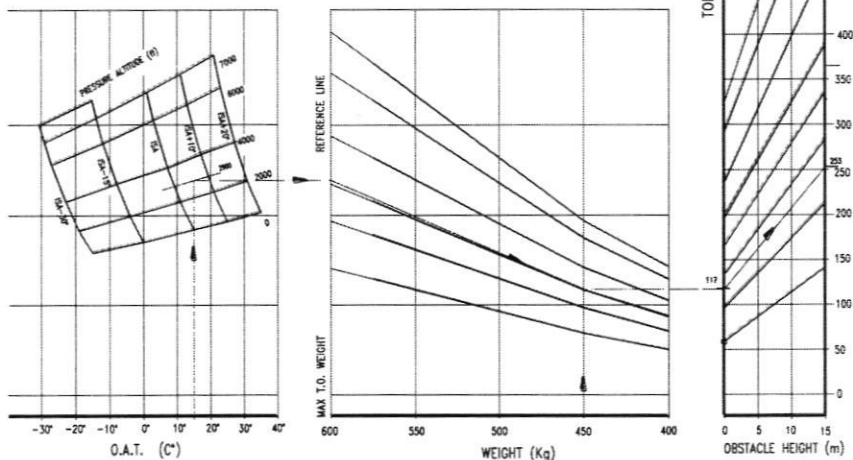

Fig. 5-4. TAKEOFF PERFORMANCE

CLIMB RATE IN TAKEOFF CONFIGURATION (*Approved data*)

CONDITIONS:

	550 kg MTOW	600 kg MTOW
- Flaps:	15°	15°
- Engine:	full throttle	full throttle
- V_{obs} :	56 KIAS	58 KIAS

Climb rate in demonstrated ISA s.l. conditions is 850 ft/min at maximum takeoff weight of 550 kg and 750ft/min at maximum takeoff weight of 600 kg.

CLIMB PERFORMANCE

CLIMB RATE IN CLEAN CONFIGURATION

CONDITIONS:

- Flaps: 0°
- Engine: full throttle
- $V_Y = 70$ KIAS for 550kg MTOW
- $V_X = 63$ KIAS for 550kg MTOW
- $V_Y = 73$ KIAS for 600kg MTOW
- $V_X = 66$ KIAS for 600kg MTOW
- R/C residual 100 ft/min.

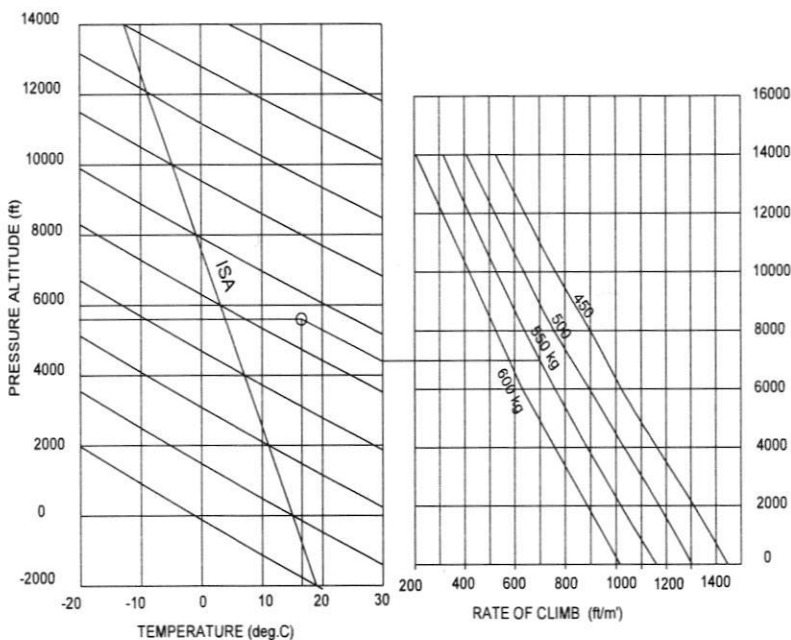

⇒ Example:

Given

O.A.T. = 17°C
 Pressure altitude = 5600 ft
 Weight = 550 Kg

Find

Rate of climb = 700 ft/min

CRUISE

CONDITIONS:

- ISA

- Maximum takeoff weight = for both MTOW

(1) Fuel tanks 2x35 liters (less the unusable fuel)

(2) Fuel tanks 2x45 liters (less the unusable fuel)

Pressure altitude H_p : **0 ft**

OAT: **+15°C**

Propeller RPM		Speed KTAS	Consumption (l/h)	¹ Endurance (hrs)		¹ Range (N.m.)	
				(1)	(2)	(1)	(2)
55%	1900	96	15	4.5	5.8	431	599
65%	2050	102	18	3.7	4.9	382	495
75%	2150	108	20	3.4	4.4	364	472

Pressure altitude H_p : **2000 ft**

OAT: **+11°C**

Propeller RPM		Speed KTAS	Consumption (l/h)	¹ Endurance (hrs)		¹ Range (N.m.)	
				(1)	(2)	(1)	(2)
55%	1950	98	15	4.5	5.8	440	571
65%	2070	106	18	3.7	4.9	397	515
73%	2150	109	19	3.5	4.6	387	501

Pressure altitude H_p : **4000 ft**

OAT: **+7°C**

Propeller RPM		Speed KTAS	Consumption (l/h)	¹ Endurance (hrs)		¹ Range (N.m.)	
				(1)	(2)	(1)	(2)
55%	2020	101	15	4.5	5.8	454	588
60%	2080	105	17	4.0	5.1	416	540
70%	2150	110	18.5	3.6	4.7	401	520

Pressure altitude H_p : **6000 ft**

OAT: **+3°C**

Propeller RPM		Speed KTAS	Consumption (l/h)	¹ Endurance (hrs)		¹ Range (N.m.)	
				(1)	(2)	(1)	(2)
55%	2060	104	15	4.5	5.8	467	606
60%	2150	108	17	4.0	5.1	429	556

¹ Range and endurance are intended approximate and referred to a "zero" wind condition.

Pressure altitude H_p : **8000 ft**

 OAT: **-0.8°C**

Propeller RPM		Speed KTAS	Consumption (l/h)	¹ Endurance (hrs)		¹ Range (N.m.)	
				(1)	(2)	(1)	(2)
55%	2120	99	15	4.5	5.8	445	578
58%	2150	102	16	4.2	5.4	428	556

 Pressure altitude H_p : **10000 ft**

 OAT: **-5°C**

Propeller RPM		Speed KTAS	Consumption (l/h)	¹ Endurance (hrs)		¹ Range (N.m.)	
				(1)	(2)	(1)	(2)
55%	2150	100	15	4.5	5.8	450	585

 Pressure altitude H_p : **12000 ft**

 OAT: **-9°C**

Propeller RPM		Speed KTAS	Consumption (l/h)	¹ Endurance (hrs)		¹ Range (N.m.)	
				(1)	(2)	(1)	(2)
50%	2150	98	14	4.8	6.2	475	617

¹ Range and endurance are intended approximate and referred to a "zero" wind condition.

BALKED LANDING

RATE OF CLIMB: BALKED LANDING

CONDITIONS:

- | | | | |
|--------------------|-----------|---------|--------------------------------|
| - Maximum weight = | 550 kg | 600kg | - Flaps: 38° |
| - V _{Obs} | = 48 KIAS | 50 KIAS | - Engine: full throttle max 5' |

NOTE

During balked landing maneuver, flaps should be retracted immediately after applying full power.

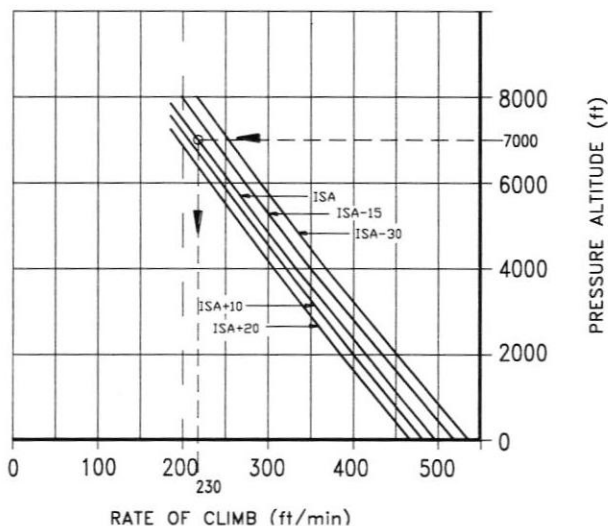

Fig.5-6. BALKED LANDING (MTOW=550KG)

⇒ Example:

Given

Pressure altitude = 7000 ft
 Conditions: ISA

Find

Rate of climb = 230 ft/min

NOTE

If the maximum takeoff weight is 600 kg, the rate of climb decreases about 10%

LANDING DISTANCE *(Approved data)*
CONDITIONS:

- Maximum weight = 550 kg (600kg)
- Brakes: maximum braking
- Slope: 0°
- Conditions: ISA
- Engine: throttle idle
- Runway: dry, compact, grass
- Wind: zero
- Flaps: 38°

Hp (ft)	0	1000	2000	3000	4000	5000	6000	7000
GR (m)	100	103	106	109	112	116	119	123
LD (m)	252	256	260	264	268	273	279	282

- Maximum weight = 600kg
- Brakes: maximum braking
- Slope: 0°
- Conditions: ISA
- Engine: throttle idle
- Runway: dry, compact, grass
- Wind: zero
- Flaps: 38°

Hp (ft)	0	1000	2000	3000	4000	5000	6000	7000
GR (m)	120	124	127	131	134	139	143	148
LD (m)	302	307	312	317	322	328	335	338

NOTE

1. *Decrease distances by 10% for each 10 Kts of headwind. Increase distances by 20 % for each 10 Kts of tailwind;*
2. *For dry and paved runway operation increase ground run by 10%;*
3. *If it becomes necessary to land without flap extension (flap malfunction), increase approach speed by 10 Kts, increase by 40% distance pertaining to flap setting at 38° and increase V_{obs} to 58 KIAS (61KIAS) for 550 kg MTOW (600 kg);*
4. *V_{obs} (speed over obstacle) is 48 KIAS (50 KIAS) for 550 kg MTOW (600 kg);*

CONSEQUENCES FROM RAIN AND INSECT

Flight tests have demonstrated that neither rain nor insect impact build-up on leading edge have caused substantial variations to aircraft's flight qualities. Such variations fall within JAR-VLA tolerance limits as they are not above: 5 Kts for stalls, 100 ft/min for climb rates and 50 m for takeoff runs.

NOISE DATA

Noise level was determined according to JAR-36 Sub.C Ed.23 May 1997 ICAO/Annex 16 Chap.10 Issue 1993, and results are shown in the following table:

	550 kg MTOW	600 kg MTOW
Noise Level (db)	63.6	65.0

**SECTION 6****WEIGHT & BALANCE /
EQUIPMENT LIST****TABLE OF CONTENTS**

INTRODUCTION	2
AIRCRAFT WEIGHING PROCEDURES.....	2
WEIGHING REPORT	3
WEIGHT AND BALANCE	5
LOADING	9
EQUIPMENT LIST	9

INTRODUCTION

This section describes the procedure for establishing the basic empty weight and moment of the aircraft. Loading procedure information is also provided.

AIRCRAFT WEIGHING PROCEDURES

PREPARATION

- a. Carry out weighing procedure inside closed hangar
- b. Remove from cabin any objects left unintentionally
- a. Insure on board presence of:
Flight manual, airnavigation certificate, navigation charts etc.
- d. Align nose wheel
- e. Drain fuel via specific drain valve.
- f. Oil, hydraulic fluid and coolant to operating levels
- g. Move sliding seats to most forward position
- h. Raise flaps to fully retracted position (0°)
- i. Place control surfaces in neutral position
- j. Place scales (min. capacity 150 kg) under each wheel

LEVELING

- a. Level the aircraft using the cabin floor as datum
- b. Center bubble on level by deflating nose tire

WEIGHING

- a. Record weight shown on each scale
- b. Repeat weighing procedure three times
- c. Calculate empty weight

DETERMINATION OF C.G. LOCATION

- a. Drop a plumb bob tangent to the leading edge (in non-tapered area of one half-wing, approximately one meter from wing root) and trace reference mark on the floor.
- b. Repeat operation for other half-wing.
- c. Stretch a taught line between the two marks
- d. Measure the distance between the reference line and main wheel axis
- e. Using recorded data it is possible to determine the aircraft's C.G. location and moment (see following table)

WEIGHING REPORT

Model **P92-JS** S/N: _____ Weighing n° _____

Date: _____

Datum: Propeller support flange w/o spacer. -Equipment list, date: _____

MAC: 1400 mm

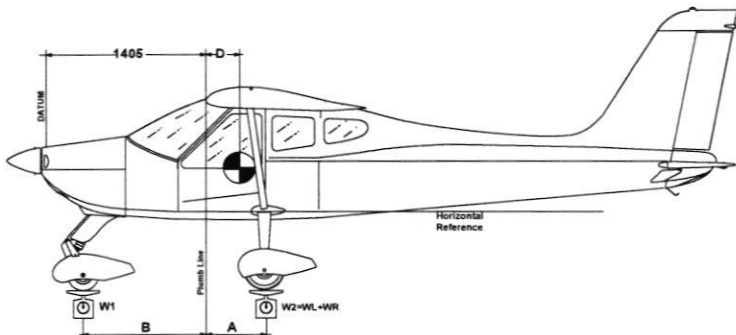

	Kg		meters
Nose wheel weight	$W_1 =$	Plumb bob distance LH wheel	$A_L =$
LH wheel weight	$W_L =$	Plumb bob distance RH wheel	$A_R =$
RH wheel weight	$W_R =$	Average distance $(A_L + A_R)/2$	$A =$
$W_2 = W_L + W_R =$		Bob distance from nose wheel	$B =$

Empty weight ⁽¹⁾ $W_e = W_1 + W_2 =$ _____

$D = \frac{W_2 \cdot A - W_1 \cdot B}{W_e} =$ _____ m	$D\% = \frac{D}{1.4} \cdot 100 =$ _____
---	---

Empty weight moment: $M = [(D+1.405) W_e] =$ _____ Kg · m

Maximum takeoff weight	$W_T = 550$ kg	$W_T = 600$ kg	Sign: _____
Empty weight	$W_e =$	$W_e =$	
Maximum payload $W_T - W_e$	$W_u =$	$W_u =$	

1 - Including unusable fuel (2.3 kg).

WEIGHING REPORT

Model **P92-JS** S/N: _____ Weighing n° _____

Date: _____

Datum: Propeller support flange w/o spacer. -Equipment list, date: _____
MAC: 1400 mm

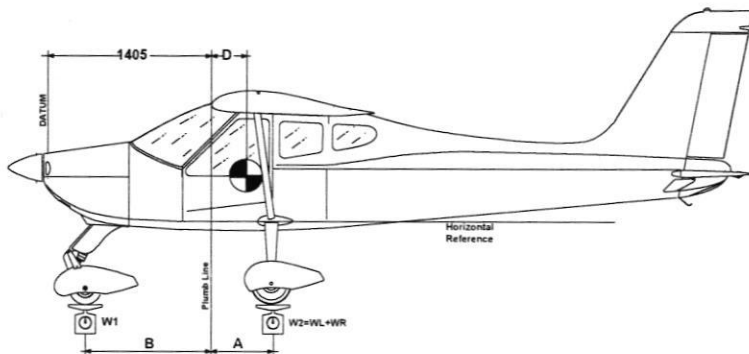

	kg		meters
Nose wheel weight	$W_1 =$	Plumb bob distance LH wheel	$A_L =$
LH wheel weight	$W_L =$	Plumb bob distance RH wheel	$A_R =$
RH wheel weight	$W_R =$	Average distance $(A_L + A_R)/2$	$A =$
$W_2 = W_L + W_R =$		Bob distance from nose wheel	$B =$

Empty weight ⁽¹⁾ $W_e = W_1 + W_2 =$ _____

$D = \frac{W_2 \cdot A - W_1 \cdot B}{W_e} =$ _____ m	$D\% = \frac{D}{1.4} \cdot 100 =$ _____
---	---

Empty weight moment: $M = [(D+1.405) \cdot W_e] =$ _____ Kg . m

Maximum takeoff weight	$W_T =$ 550 kg	$W_T =$ 600 kg
Empty weight	$W_e =$ _____	$W_e =$ _____
Maximum payload $W_T - W_e$	$W_u =$ _____	$W_u =$ _____

Sign: _____

1 - Including unusable fuel (2.3 kg).

WEIGHT AND BALANCE

To determine the aircraft's CG location and to verify that the CG falls within the predetermined CG travel range, it is necessary to use the chart in the following page. Chart reports CG location as a function of the empty weight moment with respect to the datum as yielded by weighing report.

USE OF "WEIGHT & BALANCE" CHART (page 6-6)

In order to use the graph it is necessary to know the value of the moment arm with respect to the datum. Once this value is found on the abscissa, a parallel to the oblique lines is drawn until it intersects the ordinate relative to the weight of pilot and passenger. From this point, a new line is drawn horizontally up to limit value of 180 kg and, from here, a parallel to the oblique lines is drawn until it intersects with the abscissa relative to fuel weight carried on board. A horizontal line is then drawn through this point up to limit value of 70 liters and a new parallel to the oblique lines is drawn until abscissa is intercepted relative to baggage loaded on board behind the seats. Another horizontal line is drawn and it is thus possible to verify that the intersection of this segment with the vertical abscissa relative to the aircraft's takeoff total weight falls within the shaded area which represents the admissible CG range as a function of total weight.

Pages 6 and 7 show charts of CG travel as a function of aircraft weight, distances in meters of pilots and baggage from datum (propeller support flange) is also provided.

EXAMPLE (see page 6-6)

Empty weight moment = 562 *kg · m*

Pilot and passenger = 160 *kg*

Fuel = 50 *Lit*

Baggage = 15 *kg*

Takeoff weight = 536 *kg*

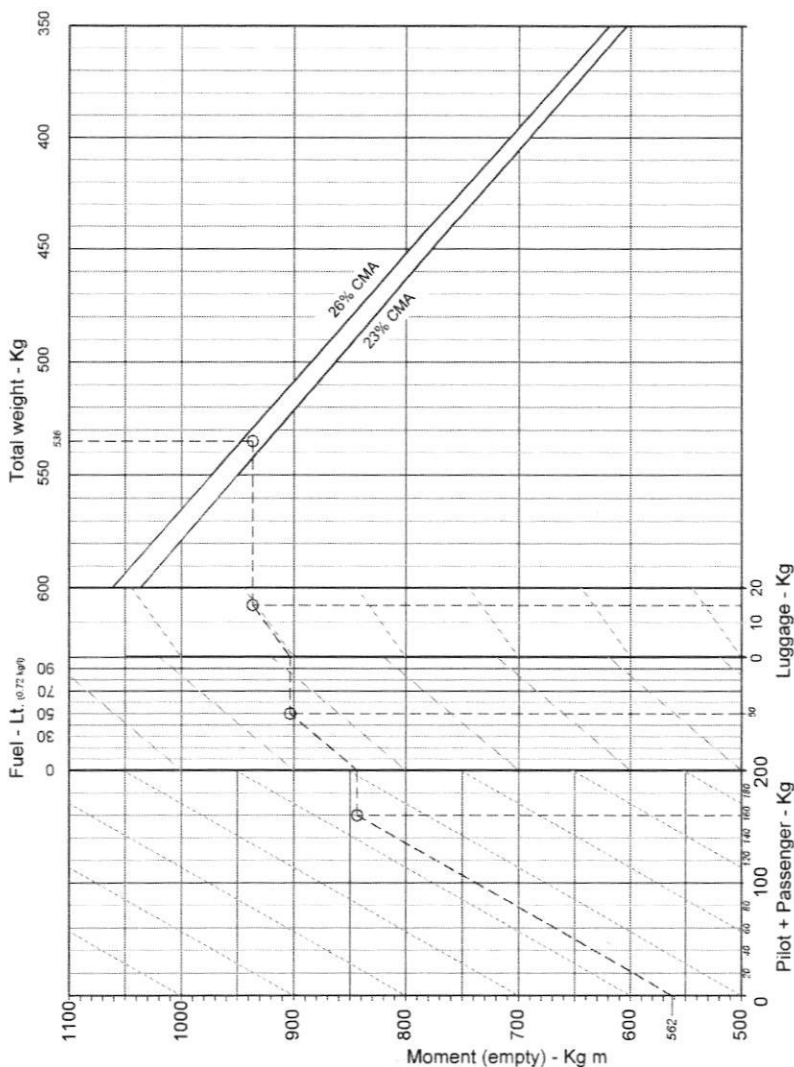

FIG. 6-1 Weight & balance chart

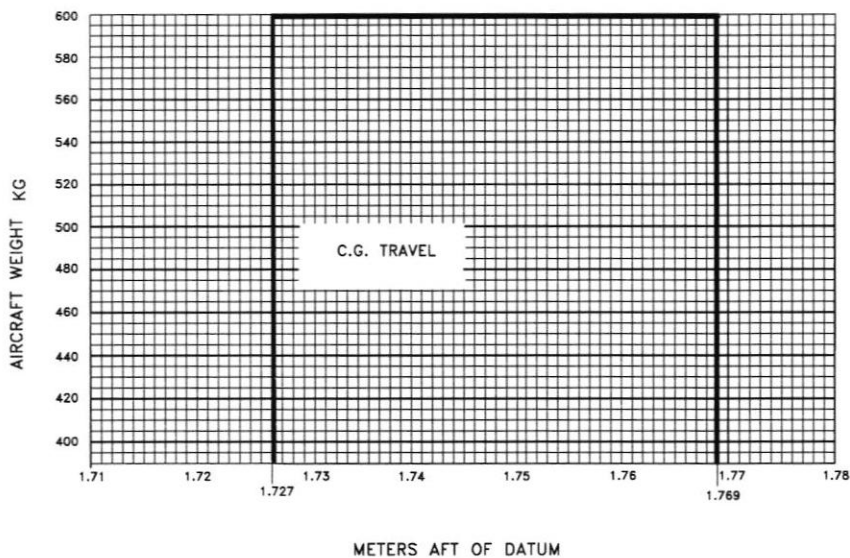

Fig 6-2. C.G. RANGE CHART.

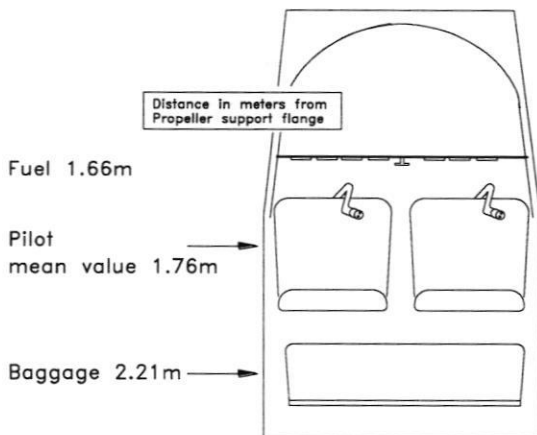

Fig 6-3. LOAD POSITION WITH RESPECT TO DATUM

LOADING

Baggage compartment is designed for a maximum load of 20 kg. Baggage size shall prevent excessive loading of utility shelf (maximum pressure 12.5 kg/dm²). Maximum baggage size is: 80x45x32 cm. Baggage shall be secured using a tie-down net to prevent any baggage movement during maneuvers.

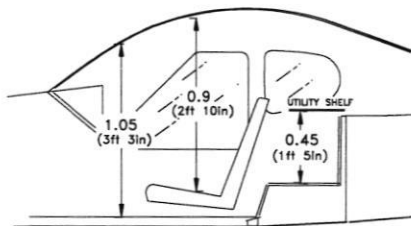

Fig 6-4. CABIN DIMENSIONS

EQUIPMENT LIST

The following is a comprehensive list of all TECNAM supplied equipment for the P92-JS. The list consists of the following groups:

- A - Engine and accessories
- B - Landing gear
- C - Electrical system
- D - Instruments
- E - Avionics

the following information describes each listing:

- Part-number to uniquely identify the item type.
- Item description
- Serial number
- Weight in kilograms
- Distance in meters from datum

NOTE

Items marked with an asterisk () are part of basic installation. Additionally, further equipment marked with X in the Inst. column are installed on the aircraft S/N in subject.*

EQUIPMENT LIST		A/C S/N	DATE:	
REF.	DESCRIPTION & P/N	INST	WEIGHT kg	DATUM m
<i>ENGINE & ACCESSORIES</i>				
A1	Engine Rotax 912S2 - p/n 309.120.133	*	59.0	0.32
A2	Prop. HOFFMANN p/n HO17GHM A 174 177C	*	4.50	-0.08
A3	Exhaust and manifolds – p/n SSB-978-480-CC	*	4.50	0.55
A4	Heat exchanger - p/n 92-11-830	*	2.00	0.55
A5	Oil Reservoir (full) - p/n 956.137 or 656.865	*	4.00	0.61
A6	Oil radiator - p/n 886 025 or 886.033	*	0.40	0.07
A7	Liquid coolant radiator. - p/n 995.697 or 997.083	*	0.90	0.33
A8	Air filter K&N- p/n 33-2544	*	0.40	0.60
A9	Vacuum instr. system – RA215CC Rapco		3.00	0.25
A10	Vacuum valve RA2H3-12		0.100	0.71
A11	Fuel pump p/n 21-11-342-000	*	0.200	0.71
A12	Fuel tank. 45 Lt. P/N 21-1-340-001/2	*	//	//
<i>LANDING GEAR AND ACCESSORIES</i>				
B1	Main gear spring-leaves - p/n 92-8-300-1	*	5.700	1.930
B2	Main gear wheel rims. - CLEVELAND 40-78B or 199-102	*	2.050	1.930
B3	Main gear tires.-AIR TRAC 5.00-5	*	2.580	1.930
B4	Disk brakes - Cleveland 30-9 or 160-17	*	0.800	1.930
B5	Nose gear wheel rim p/n 92-8-880-1 or 92-8-700-000	*	1.300	0.310
B6	Nose gear tire - 4.00-6	N	1.200	0.460
B7	Nose gear tire – AIR TRACK 5.00-5		1.500	0.460
B8	Nose gear fairing p/n 92-8-410-1/2	N	1.500	0.460
B9	Nose gear fairing p/n 27-8-420-1		1.500	0.460
B10	Main gear fairing p/n 92-8-420-1/2	x	1.500	1.930
B11	Nose gear shock p/n 92-8-200-000	*	1.450	0.465



EQUIPMENT LIST		A/C S/N	DATE:	
REF.	DESCRIPTION & P/N	INST	WEIGHT kg	DATUM m
<i>ELECTRICAL SYSTEM</i>				
C1	Battery FIAMM 6H4P 12V 18Ah		6.00	4.24
C2	Regulator, rectifier - p/n 945.345	*	0.20	0.82
C3	Battery relay - p/n 111-226-5	*	0.30	4.19
C4	Flaps actuator - SIR Mod. AO-01/M	*	2.20	2.57
C5	Flaps actuator control switch – FEME MS35059-34	*	0.08	1.20
C6	Trim actuator control Ray Allen C. T2-10A	*	0.40	5.75
C7	Overvoltage sensor OS75-14		0.30	0.80
C8	Overvoltage sensor B00289-2	*	0.30	0.80
C9	Strobe light - p/n 2005	N	0.15	5.52
C10	Navigation lights - AS W1285	N	0.15	2.30
C11	Nav-Strobe light - AVE-WPTSG-54G		0.25	2.30
C12	Stall warning AS 164R or TECNAM 21-9-420-000	*	0.10	1.95
C13	Landing light - AS GE 4509		0.50	1.50
C14	Landing light – PledIL		0.60	1.50
C15	BATTERY SPARK 500		4.9	4.24
<i>INSTRUMENTS</i>				
D1	Altimeter - – MIKROTECHINA p/n 1128.12B6 -		0.39	1.20
D2	Altimeter – United Instruments p/n 5934PM-3		0.39	1.20
D3	Airspeed ind. – MIKROTECHINA 116.B0B2	*	0.30	1.20
D4	Compass – Airpath C2400 L4P	*	0.29	1.20
D5	Clock – DAVTRON mod. M 800	*	0.15	1.20
D6	Vertical Speed Indicator – MIKROTECHINA UL 30-42.2		0.35	1.20
D7	Vertical Speed Indicator – Wultrad Inc. p/n		0.35	1.20



EQUIPMENT LIST		A/C S/N	DATE:	
REF.	DESCRIPTION & P/N	INST	WEIGHT kg	DATUM m
	BC-2A			
D8	Turn and Bank Indicator – FALCON GAUGER TC02E-3-2		0.56	1.20
D9	Turn and Bank Indicator – Mid. Continent. p/n 1394T100-TZ		0.56	1.20
D10	Attitude Indicator – FALCON G.- GH02V-3		1.10	1.20
D11	Attitude Indicator – RCA ALLEN INSTR. RCA 22-7		1.10	1.20
D12	Directional Gyro – RCA ALLEN INSTR. RCA 11A-8		1.10	1.20
D13	Directional Gyro – FALCON G.- DG02V-3		1.10	1.20
D14	OAT Indicator –397035001G VDO	*	0.05	1.20
D15	Head temp. Ind. 641-011-7047/-7048 VDO	N	0.10	1.20
D16	Head temp. Ind. SOR 53 or SOR 59	*	0.10	1.20
D17	Oil temp. ind. – VDO 644-001-7030	N	0.10	1.20
D18	Oil temp. ind SOR 54	*	0.10	1.20
D19	Vacuum instr. UMA Inc. 3-200-12	*	0.10	1.20
D20	Prop. RPM Ind. DI-112-5040 Aircraft Mitchell.	N	1.10	1.20
D21	Prop. RPM Ind. Sorlini (SOR52)	*	1.10	1.20
D22	Fuel level Ind. Road XID4.0008.00	*	0.56	1.20
D23	Oil pressure. Ind. – Sorlini (SOR50, SOR50V)		0.10	1.20
	<i>AVIONICS AND OTHER</i>			
E1	Nav/CommTrans.-Bendix/King, KX155		2.24	1.20
E2	Nav Indicator – Bendix/King KI208		0.46	1.20
E3	R/T VHF COMM Garmin SL40		1.20	1.20
E4	Transponder – Bendix/King KT76A		1.36	1.20
E5	Receiver GPS/NAV e r/t COM GNS 430W		2.31	1.20
E6	R/T VHF COMM IC-A200 ICOM		1.20	1.20
E7	ELT ARTEX ME 406		1.10	2.70



EQUIPMENT LIST		A/C S/N	DATE:	
REF.	DESCRIPTION & P/N	INST	WEIGHT kg	DATUM m
E8	Transponder-Garmin GTX328 or GTX335		1.00	1.20
E9	Audio panel –Garmin GMA 340 or 345		0.50	1.20
E10	Vor/Loc Indicator –Garmin GI106()		0.64	1.20
E11	Antenna KA 92 GPS		0.27	1.07
E12	Antenna Transp.-Bendix/King KA60		0.35	1.50
E13	Antenna GPS – Garmin 1012		0.17	1.07
E14	Microphone – Telex TRA 100		0.17	1.90
E15	Antenna Garmin GA35		0.27	1.08
E16	Antenna Comm CI 291 or CI 121	*	0.34	3.30
E17	Antenna VOR/ILS CI 138C or CI 158C		0.26	5.60
E18	Antenna ELT		0.21	2.70
E19	Fire extinguisher Fire fighting Enterprises Ltd BA51015-3		2.20	2.16
E20	Fire extinguisher – HALON H3G 1301 or AMEREX A344		1.00	2.16
E21	First Aid Kit	*	0.28	2.60
E22	Altitude Encoder – Amery King A30		0.56	1.00
E23	ADF Receiver – Bendix King KR87		1.38	1.20
E24	ADF Indicator – Bendix King KI227		0.39	1.20
E25	ADF Antenna – Bendix King KA44B		1.89	2.05
E26	GTN 650		3.20	1.20
E27	GTR225A		1.07	1.20
E28	GNC 255 or 255A		1.36	1.20
E29	ELT ACK E04 or Kannad Compact / Integra		1.00	2.70
E30	Transponder Antenna CI 105		0.11	1.50
E31	Antenna Marker CI102		0.27	2.70



LEFT INTENTIONALLY BLANK

SECTION 7**AIRCRAFT & SYSTEMS DESCRIPTION****TABLE OF CONTENTS**

INTRODUCTION	2
AIRFRAME	2
FLIGHT CONTROLS	3
INSTRUMENT PANEL	4
SEATS AND SAFETY HARNESS	5
DOORS	5
Baggage COMPARTMENT	5
POWERPLANT	6
FUEL SYSTEM	6
ELECTRICAL SYSTEM	8
PITOT AND STATIC PRESSURE SYSTEMS	10
BRAKES	11
MARKING & PLACARDS	11
PLACARDS OUTSIDE CABIN	15

INTRODUCTION

This section provides description and operation of the aircraft and its systems.

AIRFRAME

WING

The wing is constructed of a central light alloy torque box; an aluminum leading edge with integrated fuel tank is attached to the front spar while flap and aileron are hinged to rear spar. Flaps are constructed of a center spar to which front and rear ribs are joined; wrap-around aluminum skin panels cover the flap structure. The aileron is constructed of an aluminum spar to which a formed sheet metal leading edge and metal ribs are attached; a wrap-around, thermosetting synthetic material covers aileron structure.

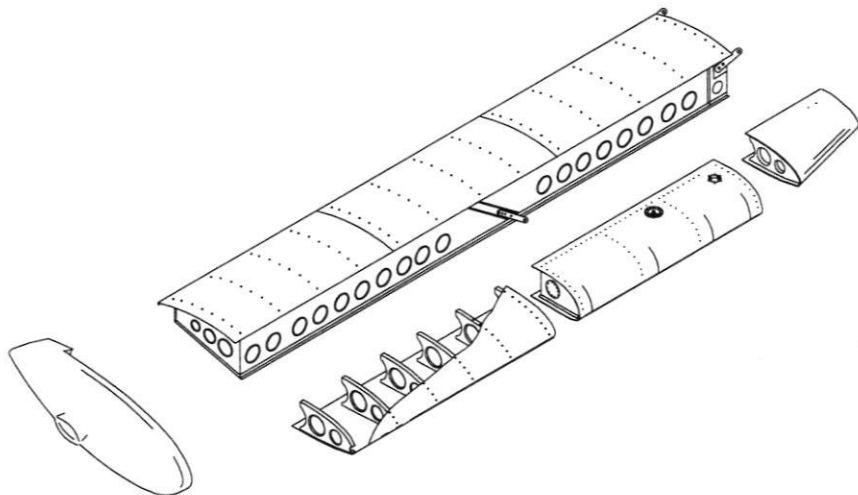

Fig. 7-1. RIGHT WING EXPLODED VIEW

FUSELAGE

The front part of the fuselage is made up of a mixed structure: a truss structure with special steel members for cabin survival cell, and a light-alloy semi-monocoque structure for the cabin's bottom section. The aft part of the fuselage is constructed of an aluminum alloy semi-monocoque structure. The engine housing is isolated from the cabin by a stainless steel firewall; the steel stringers engine mount is attached to the cabin's truss structure in four points.

EMPENNAGES

The vertical tail is entirely metal: the vertical stabilizer is made up of a twin spar with stressed skin while the rudder consists of an aluminum torque stringer connected to light alloy ribs and skin. The horizontal tail is an all-moving type (stabilator); its structure consists of an aluminum tubular spar connected to ribs and leading edge; wrap-around thermoretractible synthetic material covers the stabilator structure.

FLIGHT CONTROLS

Aircraft flight controls are operated through conventional stick and rudder pedals. Longitudinal control acts through a system of push-rods and is equipped with a trim tab. Aileron control is of mixed type with push-rods and cables; the cable control circuit is confined within the cabin and is connected to a pair of push-rods positioned in the wings that control ailerons differentially. Aileron trimming is carried out on ground through a small tab positioned on left aileron.

Flaps are extended via an electric servo actuator controlled by a switch on the instrument panel. Flaps act in continuous mode, the indicator displays the two positions relative to takeoff (15°) and landing (38°). A breaker positioned on the right side of the instrument panel protects the electric circuit.

Longitudinal trim is performed by a small tab positioned on the stabilator and controlled via an electric servo by pushing an Up/Down push-button on the control stick. A shunt switch placed on the instrument panel enables control of either left or right stick; in addition, a safety switch positioned by the trim indicator shuts off power from the circuit in case of emergency (see section 3).

INSTRUMENT PANEL

The conventional type instrument panel allows placement of a broad range of equipment. Instruments marked with an asterisk () are optional.*

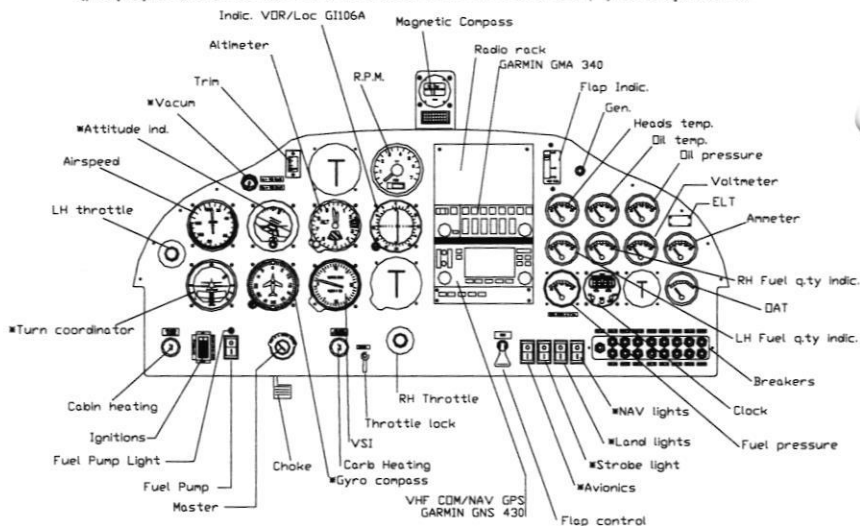

Fig. 7-2. INSTRUMENT PANEL

CARBURETOR HEAT

Carburetor heat control knob is square shaped and is located just to the left of the center throttle control; when the knob is pulled fully outward from the instrument panel, carbs receive maximum hot air. During normal operation, the knob is OFF.

CABIN HEAT

The cabin heat control knob is positioned on the lower left side of the instrument panel; when knob is pulled fully outward, cabin receives maximum hot air. Vents are located by the rudder pedals and above instrument panel. If necessary, outside fresh air can be circulated inside cabin by opening door vents.



THROTTLE FRICTION LOCK

It is possible to adjust the engine's throttle friction lock by appropriately tightening the friction lock disk located on the instrument panel near the center throttle control.

SEATS AND SAFETY HARNESS

Aircraft features three point fitting safety belts with waist and diagonal straps adjustable via a sliding metal buckle.

Seats are built with light alloy tube structure and synthetic material cushioning. A lever located on the right lower side of each seat allows for seat adjustment according to pilot size.

DOORS

Aircraft doors feature external and internal door handles with door-lock provided externally on left side door. An internal safety latch mechanism is positioned in proximity of door's upper edge and must be used before flight to secure door. Mechanism rotates to engage doorframe to cabin tubular framework.

BAGGAGE COMPARTMENT

The baggage compartment is located behind the pilots' seats. Baggage shall be uniformly distributed on utility shelf and its weight shall not exceed 20kg. Tie-down baggage using adjustable tie-down net.

WARNING

Before loading baggage, check aircraft's weight and CG location (see section 6).

POWERPLANT

ENGINE ROTAX 912S2, 4 stroke, horizontally-opposed 4 cylinder, mixed air and water cooled, twin electronic ignition, forced lubrication
Maximum rating – 98.6hp (73.5Kw) @ 5800 rpm/min (2388 rpm/min. prop).
Gear reduction ratio - 2.4286:1
For further information see: “*Engine Operating Manual*”.
Engine control instruments are located on right side of instrument panel.

PROPELLER wood twin blade HOFFMAN type: HO17GHM-174 177C or HO17GHM A 174 177C; for further information see “*Service Manual*” for P92-JS and “*Propeller Service Manual*”.

FUEL SYSTEM

The system is equipped with two aluminum fuel tanks integrated within the wing leading edge and accessible for inspection through dedicated covers. Capacity of individual tank is 35lt (45lt optional) and total usable fuel is 66.8lt (86.8 lt). Each fuel tank is equipped with a cabin installed shutoff valve. A strainer cup with a drainage valve (Gascolator) is located on the engine side of the firewall. Fuel level indicators for each tank are located on instrument panel. Fuel feed is through an engine-driven mechanical pump and through an electric pump for emergencies (normally ON for takeoff) that supplies adequate engine feed in case of main pump failure. All fuel lines located in the engine compartment are protected with fireproof braiding to avoid possible fire. Figure 7-3 illustrates the schematic of the fuel system.

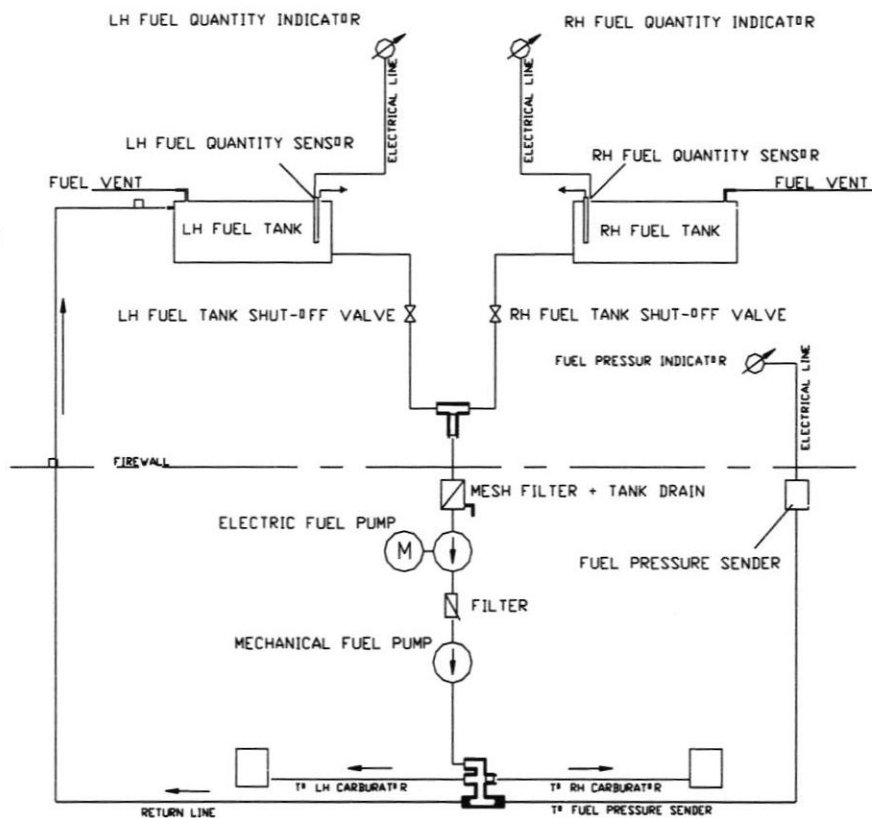

Fig. 7-3. FUEL SYSTEM SCHEMATIC

ELECTRICAL SYSTEM

The aircraft's electrical system consists of a 12 Volt DC circuit controlled by the Generator Switch located on the instrument panel. Electricity is provided by an alternator and by a buffer battery placed in the fuselage tail section. Generator light is located on the right side of the instrument panel.

WARNING

If the ignition key is in the position L, R or BOTH an accidental movement of the propeller may start the engine with possible danger for bystanders.

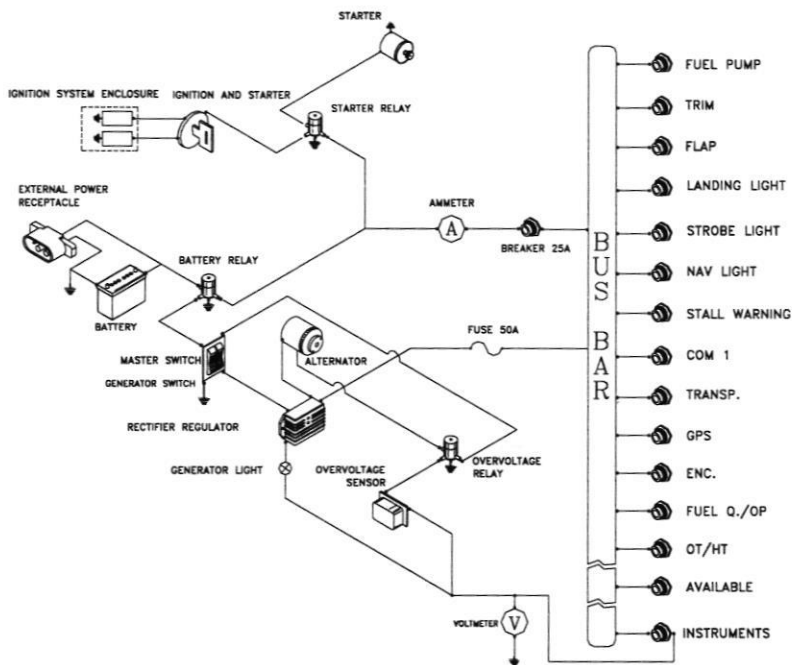

FIG. 7-4. ELECTRICAL SYSTEM SCHEMATIC

GENERATOR LIGHT

Generator light (red) illuminates for the following conditions:

- Generator failure
- Failure of regulator/rectifier, with consequent overvoltage sensor set off.

The battery can support energy requirements for 26 min (see page 3-8)

VOLT-AMMETER

The voltmeter indicates voltage on bus bar; a positive value of the ammeter indicates the generator is charging the battery, a negative value indicates the battery's discharge rate.

OIL AND CYLINDER HEADS TEMP. - OIL PRESSURE

These instruments are connected in series with their respective sensors. The same breaker protects all temperature instruments while a second breaker protects oil pressure indicator and other instruments.

O.A.T. INDICATOR

A digital Outside Air Temperature indicator (°C) is located on the upper left side of the instrument panel. The sensor is placed on cabin top.

STALL WARNING SYSTEM

The aircraft is equipped with a stall warning system consisting of a sensor located on the right wing leading edge connected to a warning noisemaker located on the instrument panel.

AVIONICS

The central part of the instrument panel holds room for avionics equipment. The manufacturer of each individual system furnishes features for each system.

EXTERNAL POWER SUPPLY

On the right side of the tail cone, an external power is present. Using this device it is possible to feed the electric system by an external power source. It should be used at the engine start-up in cold weather condition.

Follow this procedure to start the engine using the external power source.

1. Magnetos, Master switch, Generator switch: OFF
2. Open the receptacle door and insert the external power source's plug into the socket
3. Engine start-up procedure (see Sect. 4 in this manual)
4. Disconnect the external power source's plug and close firmly the receptacle door.

PITOT AND STATIC PRESSURE SYSTEMS

The airspeed indicator system for the aircraft is shown below and consists of two static ports located on the sides of the aircraft forward of the cabin and by a pitot tube located on the left wing strut.

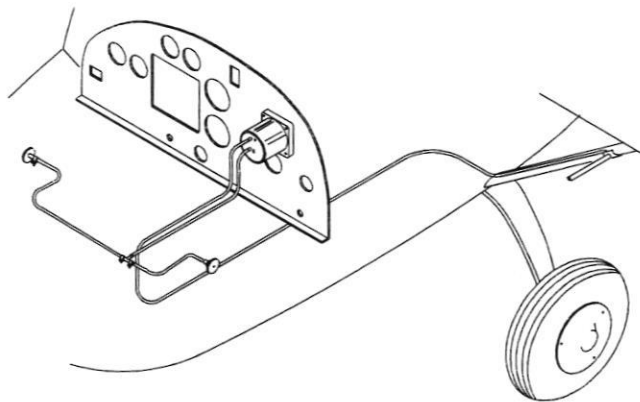

FIG. 7-5. AIRSPEED INDICATOR SYSTEM

BRAKES

The aircraft's braking system is a single system acting on both wheels of main landing gear through disk brakes, the same circuit acts as parking brake via an intercept valve.

To activate brakes it is sufficient to verify that brake shut-off valve positioned on tunnel between pilots is OFF, then activate brake lever as necessary.

To activate parking brake pull brake lever and set brake shut-off valve to ON.

MARKING & PLACARDS

To compensate for deviation errors of the magnetic compass, the following correction card is located immediately below compass:

For	N	30	60	E	120	150
Steer						
For	S	210	240	W	300	330
Steer						

DATE

RADIO ON

AIRPATH

This placard has to be compiled by certified operator with valid and proper instrumentation.

The following placard is located on the cabin's floor tunnel, near the hydraulic brake circuit shutoff valve:

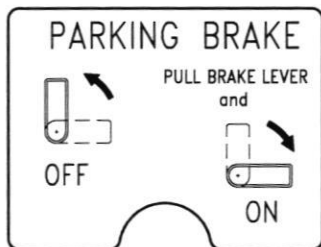

Refer to section 9 for possible variations.

Two throttle control knobs are located on instrument panel. One is positioned centrally while the other is on the upper left-hand side. The following placard is near each one:



A throttle friction lock is located on the instrument panel to maintain desired setting. The following placard is positioned near friction lock:

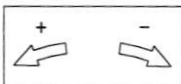

Refer to section 9 for possible variations.



Fuel shutoff valves are located on cabin truss forward members. RH valve shuts off fuel flow from RH fuel tank; LH valve shuts off fuel flow from LH fuel tank. When valve lever is aligned with truss member, the valve is open; if lever is rotated 90° wrt truss member, the valve is closed. A 20x8mm OPEN - CLOSED placard is placed near each shutoff valve. The following placard is placed near the RH forward truss member shutoff valve:

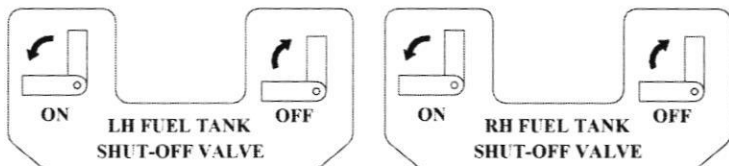

The cabin heat control knob is located on the instrument panel central area just to the right of the throttle control; the following placard is next to it:

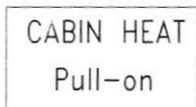

The carburetor heat control knob is located on the instrument panel central area just to the left of the throttle control; the following placard is next to it:

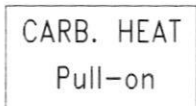

The trim switch control is located on the upper central area of the instrument panel alternatively allocating trim control to either RH or LH control stick. The following placard is positioned just above it:

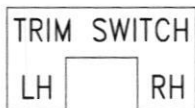

A switch located on the upper central area of the instrument panel interrupts power supply to the trim system in case of malfunction. The following placard is positioned near switch:

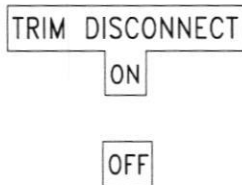

Circuit breakers are located on lower right side of instrument panel and each breaker is individually marked as follows: (from left to right):

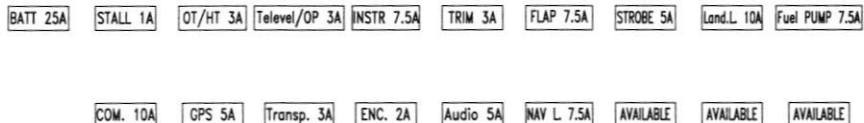

The flap control switch is located on the lower portion of the instrument panel, slightly towards the right. The following placards are just next to it:



A placard measuring 74x7 mm is located on the instrument panel to indicate fire extinguisher position:

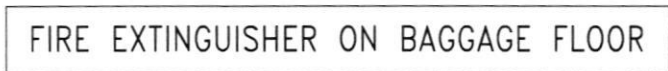

Generator and Master switches are located on the lower left side of the instrument panel and 4 labels are placed around them: one on top, one on RH side, one on bottom and one on LH side:

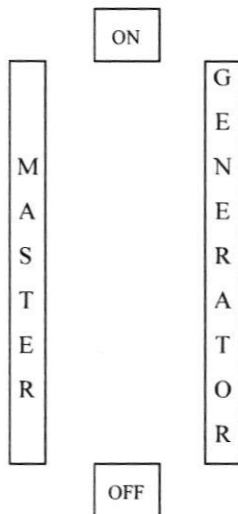

A generator warning light is located on the upper right side of the instrument panel and is marked with the following label:

ALT

PLACARDS OUTSIDE CABIN

The overflow reservoir cap for antifreeze liquid bears the following placard:

80% ANTIFREEZE
+
20% WATER

Brake fluid reservoir cap bears the following placard:

SPECIFY
HYDRAULIC OIL
MIL H5606

The following placard is located in proximity of fuel filler caps (28x63mm):

AUTOMOTIVE FUEL, ROZ MIN. 95 OCT.
LEADED OR UNLEADED

AVGAS 100LL

CAPACITY 35 LT (9.2 US gal.)

AUTOMOTIVE FUEL, ROZ MIN. 95 OCT.
LEADED OR UNLEADED

AVGAS 100LL

CAPACITY 45 LT (11.9 US gal.)

The following placards are located on oil reservoir:

AUTOMOTIVE OIL
API "SF" OR "SG"

AUTOMOTIVE OIL
CAPACITY 3.0 LT

The following label is located below each door for emergency opening:

IN CASE OF EMERGENCY
GRASP HANDLE AND
 PULL WITH FORCE HERE

Main landing gear tire inflation pressure is indicated in the following label affixed on each spring-leaf strut:

40 PSI
2.8 Bar

The following label indicates inflation pressure for nose gear tire and is affixed on nose gear assy (32 psi if the 5.00 tire is installed and 15 psi if 4.00 tire is installed):

32 PSI
2.2 Bar

15 PSI
1.0 Bar

The 0° reference mark for stabilator balance is located on left hand side of tail cone in proximity of stabilator

0° STABIL.

The following aircraft identification placard is located on tail cone:

TECNAM S.R.L.

P92 - JS

S/N _____

CERT. N° A-412

On the right side of the tail cone, next to the battery case access door, is present the following placard (69x17mm):

BATTERY INSIDE



On the right side of the tail cone, on the power receptacle's door is present the following placard (135x25mm).

**EXTERNAL POWER RECEPTACLE
12 Volt - DC**

On both the main landing gear fairings the following placard (120x22mm) is present:

NO STEP



SECTION 8

GROUND HANDLING & SERVICE

TABLE OF CONTENTS

INTRODUCTION	2
AIRCRAFT INSPECTION PERIODS	2
AIRCRAFT ALTERATIONS OR REPAIRS	2
GROUND HANDLING.....	2
CLEANING AND CARE.....	3

INTRODUCTION

This section contains factory-recommended procedures for proper ground handling and routine care and servicing. It also identifies certain inspection and maintenance requirements, which must be followed if the aircraft is to retain its new-plane performance and dependability. It is recommended to follow a planned schedule of lubrication and preventive maintenance based on climatic and flying conditions encountered locally.

AIRCRAFT INSPECTION PERIODS

Inspection intervals occur at 100 hours and in accordance with special inspection schedules which are added to regularly scheduled inspections. Correct maintenance procedures are described in the aircraft's Service Manual or in the engine's Service Manual.

AIRCRAFT ALTERATIONS OR REPAIRS

It is essential that the responsible Airworthiness Authority be contacted prior to any alterations on the aircraft to ensure that airworthiness of the aircraft is not violated. For repairs, refer to aircraft's Service Manual.

GROUND HANDLING

TOWING

The aircraft is most easily and safely maneuvered by hand by pushing on wing struts near attachments or by pulling it by its propeller near the axle. A tow bar can be fixed onto nose gear fork. Aircraft may be steered by turning rudder or, for steep turns, by pushing lightly on tailcone to lift nose wheel.

PARKING AND TIE-DOWN

When parking airplane outdoors, head it into the wind and set the parking brake. If chocks or wedges are available it is preferable to use the latter.

In severe weather and high wind conditions it is wise to tie the airplane down. Tie-down ropes shall be fastened to the wing strut attachments and anchoring shall be provided by ramp tie-downs. Nose gear fork can be used for front tie-down location.

Flight controls shall be secured to avoid possible weathervaning damage to moving surfaces. For this purpose, seatbelts may be used to latch control stick to prevent its movement.

JACKING

Given the light empty weight of the aircraft, lifting one of the main wheels can easily be accomplished even without the use of hydraulic jacks. Remove the aluminum panel located between the steel springs and, while one person lifts one half-wing by acting on the spar immediately before the wingtip, another person will place a suitable stand with protective cover under the steel spring attachment.

LEVELING

Aircraft leveling may become necessary to check wing incidence, dihedral or the exact location of CG. Leveling is obtained when the cabin floor and, in transverse direction, the main gear support beam are horizontal.

ROAD TRANSPORT

It is recommended to secure tightly all aircraft components onto the cart to avoid damage during transport. Minimum cart size is 7x2.5 meters. It is suggested to place wings under the aircraft's bottom, secured by specific clamps. Secondary components such as stabilator and struts shall be protected from accidental hits using plastic or other material. For correct rigging and de-rigging procedure, refer to Service Manual.

CLEANING AND CARE

To clean painted surfaces, use a mild detergent such as shampoo normally used for car finish; use a soft cloth for drying

The plastic windshield and windows should never be dusted when dry; use lukewarm soapy water and dry using chamois only. It is possible to use special glass detergents but, in any case, never use products such as gasoline, alcohol, acetone or other solvents.

To clean cabin interior, seats, upholstery and carpet, it is generally recommended to use foam-type detergents.

LEFT INTENTIONALLY BLANK

SECTION 9

SUPPLEMENTS

TABLE OF CONTENTS

GARMIN GNS 430 GPS/VHF COMM/NAV	3
1 INTRODUCTION	3
1.2 GENERAL	3
1.3 LIMITATIONS	4
1.4 EMERGENCY PROCEDURES	5
1.5 NORMAL OPERATION	5
1.6 PERFORMANCE	5
1.7 WEIGHT AND BALANCE	6
1.8 SYSTEMS	6
BANNER TOWING	7
2 INTRODUCTION	7
2.2 GENERAL	7
2.3 LIMITATIONS	7
2.4 EMERGENCY PROCEDURES	9
2.5 NORMAL PROCEDURES	9
2.6 PERFORMANCE	11
2.7 WEIGHT & BALANCE	14
EQUIPMENT LIST	14
2.8 SYSTEMS	18
DIFFERENTIAL BRAKE SYSTEM	18
3 INTRODUCTION	18
3.1 GENERAL	18
3.2 LIMITATIONS	18
3.3 EMERGENCY PROCEDURES	18
3.4 NORMAL OPERATION	18



3.5	PERFORMANCE.....	18
3.6	WEIGHT AND BALANCE.....	18
3.7	SYSTEMS.....	19
	CENTRAL THROTTLE CONTROL SYSTEM.....	21
4	INTRODUCTION.....	21
4.1	GENERAL.....	21
4.2	LIMITATIONS.....	21
4.3	EMERGENCY PROCEDURES.....	21
4.4	NORMAL OPERATION.....	21
4.5	PERFORMANCE.....	21
4.6	WEIGHT AND BALANCE.....	21
4.7	SYSTEMS.....	22
	NEW ANALOGICAL INSTRUMENTS PANEL.....	23
5	INTRODUCTION.....	23
5.2	GENERAL.....	23
5.3	LIMITATIONS.....	23
5.4	EMERGENCY PROCEDURES.....	23
5.5	NORMAL OPERATION.....	23
5.6	PERFORMANCE.....	23
5.7	WEIGHT AND BALANCE.....	23
5.8	SYSTEMS.....	24
	CHINESE AIRCRAFT FLIGHT MANUAL SUPPLEMENT.....	25
6	Placard in Chinese.....	26
	ARGENTINA AIRCRAFT FLIGHT MANUAL SUPPLEMENT.....	29
7	INTRODUCTION.....	30
7.2	GENERAL.....	30
7.3	LIMITATIONS.....	30
7.3.1	FUEL.....	30
7.3.2	REQUIRED EQUIPMENT.....	31
7.3.3	LIMITATION PLACARDS.....	31
7.4	EMERGENCY PROCEDURES.....	31
7.5	NORMAL OPERATION.....	31
7.6	PERFORMANCE.....	32
7.7	WEIGHT AND BALANCE.....	32
7.8	AIRCRAFT & SYSTEMS DESCRIPTION.....	32

**SUPPLEMENT N° 1****GARMIN GNS 430 GPS/VHF COMM/NAV****1 INTRODUCTION**

This section contains supplementary information for safe and efficient operation of the aircraft if equipped with a Garmin GNS 430 system.

1.2 GENERAL

1. The GPS GNS 430 Global Positioning System is an integrated system that contains a GPS navigation system in addition to a VHF COMM radio transceiver and a VOR/ILS receiver.
2. The system includes an antenna for GPS, a receiver for GPS, a VOR/LOC antenna, a VOR/ILS receiver, a VHF Comm antenna and a VHF Comm transceiver.
3. The main function of the VHF Comm is to allow communication with the control tower.
4. The VOR/ILS function is to receive and demodulate VOR and LOC signals.
5. The GPS section is dedicated to signal acquisition from the GPS satellite system and to furnish real-time information with respect to position, speed and time.
6. With appropriate signals the GPS GNS 430 can:
 - plan VFR/IFR routes, track waypoints and plan non-precision instrument approaches (GPS, LORAN-C, VOR, VOR-DME, TACAN, NDB, NDB-DME, RNAV) in accordance with AC 20-138;
7. Reference coordinates used for navigation are WGS-84.

1.3 LIMITATIONS

1. The "Pilot's guide and Reference" p/n 190-00140-00 rev. F dated July 2000 or later versions, must be available for proper use of the instrument.
2. Only VFR use is permitted.
3. The GPS section must use the following (or more recently approved) software versions:

<i>Subsystem</i>	<i>Software version</i>
MAIN	2.00
GPS	2.00
COMM	1.22
VOR/LOC	1.25

The software version of the main subsystem is displayed by the GNS 430 immediately after start-up for 5 seconds. Remaining subsystems software versions may be verified in sub-page 2 of the AUX Group display for "SOFTWARE/DATA BASE VER".

4. The following default settings must be keyed-in in the SETUP 1 menu of the GNS430 receiver before any other operation:
 - **DIS, SPD** nm kt (*select navigation unit to "nautical miles" and "knots"*);
 - **ALT, VS** ft fpm (*select altitude to "feet" and "feet per minute"*);
 - **MAP DATUM** WGS 84 (*select map datum WGS84*);
 - **POSN** deg-min (*select grid for nav unit to decimal-minutes*);



1.4 EMERGENCY PROCEDURES

1. If the information provided by the Garmin GNS430 is not available or manifestly wrong, it is necessary to use other navigation instruments.
2. If the message "WARN" appears in the lower left portion of the display, the receiver cannot be considered useful as a navigation aid. The pilot must use the VLOC receiver or an alternative navigation system.
3. If the message "INTEG" appears in the lower left portion of the display, the RAIM function is unavailable. The pilot must use the VLOC receiver or an alternative navigation system;
4. In emergency flight conditions, pressing the COM flip-flop knob for 2 seconds will automatically tune-in the 121.500MHz emergency frequency.

1.5 NORMAL OPERATION

1. DETAIL FOR NORMAL OPERATION

Normal operation is described in the "Pilot's guide and Reference" P/N 190-00140-00 rev. F dated July 2000 or later versions.

2. GARMIN GNS 430 DISPLAY.

Data for GNS 430 system appears on GARMIN GNS430 display.

Data source is either the GPS or the VLOC as indicated above the CDI switch of the GARMIN 430 display.

1.6 PERFORMANCE

No variations.



1.7 WEIGHT AND BALANCE

See section 6 of the present manual.

1.8 SYSTEMS

See "GNS 430 Pilot's Guide" p/n 190-00140-00 rev. F dated July 2000 or later versions, for a complete description of the system.

SUPPLEMENT No. 2**BANNER TOWING****2 INTRODUCTION**

This section contains supplementary information for a safe and efficient operation of the aircraft if equipped with a hook for towing banners (Mod. Number 92/27).

2.2 GENERAL**CERTIFICATION BASIS**

This installation has been certified under the technical specifications listed into the Tecnam Report 92/104.

2.3 LIMITATIONS

Section 2 includes operating limitations, instrument markings, and basic placards necessary for safe banner-towing operations.

APPROVED BANNER DIMENSION

The banner approved to be operated with the P92-JS is of the type equipped with wheels. The maximum banner surface that has been towed during the tests is 140m².

WEIGHT

The aircraft's MTOW equipped with a 140m² banner reaches 460kg.
For banners whose surface is lower than 140m², please refer to the table in paragraph 2.5 in this Section.

AIRFIELD ALTITUDE

The highest approved airfield altitude for take-off operations while towing banner of 140m² is 3000ft.

**AIRSPEED**

For all flap settings, the minimum towing airspeed is **53 KIAS**.

WARNING

The maximum towing airspeed depends on the banner's surface.
For further information, please refer to the banner manufacturer specifications/limitations.

APPROVED MANEOUVRES

The P92-JS, while towing a banner, is cleared to do only the manoeuvres pertinent to normal flight.

DEMONSTRATED CROSS WIND OPERATIONS

The aircraft's controllability was investigated during take-off with a cross wind velocity of **5** kts.

LIMITATION PALACARDS

On the instrument panel the following limitation placards must be present:

MINIMUM TOWING AIRSPEED = 53 KIAS

**REFER TO FLIGHT MANUAL
SUPPLEMENT 9.2 FOR
LIMITATIONS DURING
TOWING OPERATIONS.**

2.4 EMERGENCY PROCEDURES

EMERGENCY RELEASE

1. Find a safe location on the ground for the banner's release
2. Activate the release lever.

If the banner is properly released:

3. Control the a/c
4. Land

If the banner doesn't release:

5. Flap: *as necessary*
6. Engine throttle: *as necessary*
7. If the runway's length allows, set a landing glide so as to ground the banner at the runway's head.
8. Control the banner's position
9. Land.

NOTE

If the banner is hold by an obstacle on the ground, it automatically detaches from the towing rope by means of a calibrated collapsible link.

The load at which the link collapses depends on the banner's dimension.

For further information, please refer to the banner's manufacturer manual.

2.5 NORMAL PROCEDURES

In addition to what has been specified in Section 4, before each flight it is necessary to carry out the extra inspections listed below.

CABIN INSPECTION

- Weight and airfield altitude: check for compatibility with the Section 9.2 Limitations.
- Release lever: check.

EXTERNAL INSPECTION

- Adjust the rear view mirror and check for a proper fastening

- Release hook: check functionality.

BEFORE TAKE-OFF

- The banner will be either unfolded along the runway or placed properly folded.
- Place the banner behind the a/c so as to straighten the towing ropes (see picture below).

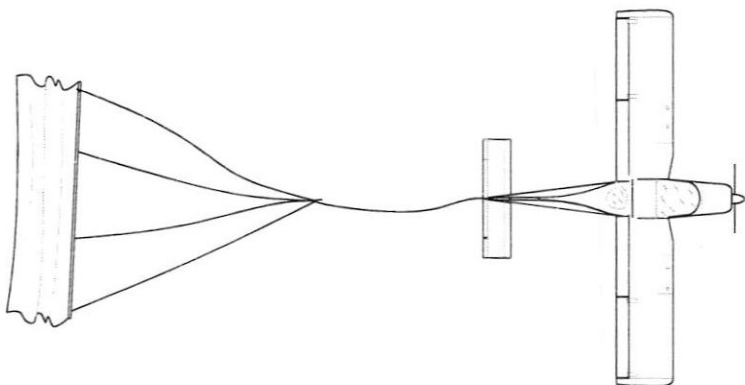

- Check the banner and its link to the aeroplane to insure that the connection has properly done and in compliance with the manufacturer instructions.

TAKE OFF AND CLIMB

WARNING

In order to reduce the banner's ground drag, the take-off should be done on a paved runway or on a short/dry grass runway



- Check the banner position through the rear view mirror.

CRUISE

- While cruising, please remember that the banner flies approx 50ft below the aeroplane.

BEFORE LANDING

- Check the banner attitude.
- Set a glide to release the banner on the runway.
- To avoid banner's damage, release it at a height above ground level, not exceeding 100ft.
- Pull the release lever.
- Proceed with a normal landing and check that the banner has been removed from the runway.

2.6 PERFORMANCE

INTRODUCTION

This section provides all necessary data for accurate and comprehensive planning of flight activity from take-off to landing in towing conditions.

Sections approved by EASA are marked by "*Approved data*" immediately following the paragraph head line.

TAKE-OFF PERFORMANCES (Approved data).
TAKE-OFF RUN AND DISTANCE, TOWING A BANNER UP TO 140 m².
CONDITIONS:

- Flap: 15°
- Take-off weight **460 kg**
- Engine throttle: Full
- Runway: dry, compact grass runway
- Runway slope: 0°
- Wind: zero

Banner' surface = 140 m²

Peso A/m kg	Press Alt ft	5 °C		15 °C		25 °C		35 °C	
		GRND ROLL m	DISTANCE 15 m OBS m	GRND ROLL m	DISTANCE 15 m OBS m	GRND ROLL m	DISTANCE 15 m OBS m	GRND ROLL m	DISTANCE 15 m OBS m
460	0	106	232	199	437	279	612	357	784
	1000	115	253	217	476	304	667	390	855
	2000	126	276	237	520	332	729	425	933
	3000	137	301	259	568	363	796	465	1019

WARNING

To obtain a take-off climb rate of 2m/s, or higher, from every airfield altitude and temperature conditions, the maximum take-off weight (with a banner of 140m²) should not exceed 460kg.

TAKE-OFF RUN AND DISTANCE, TOWING A BANNER OF NOT MORE THAN 90 m²
CONDITIONS:

- Flap: 15°
- Take off weight: 550 kg
- Engine throttle: Full
- Runway: dry, compact grass runway
- Runway slope: 0°
- Wind: zero

Banner's surface = 90 m²

Peso A/m kg	Press Alt ft	5 °C		15 °C		25 °C		35 °C	
		GRND ROLL m	DISTANCE 15 m OBS m	GRND ROLL m	DISTANCE 15 m OBS m	GRND ROLL m	DISTANCE 15 m OBS m	GRND ROLL m	DISTANCE 15 m OBS m
550	0	104	229	196	431	275	604	352	773
	1000	114	249	214	470	300	659	385	844
	2000	124	272	234	513	328	719	420	921
	3000	136	297	256	561	358	786	459	1006

Banner's surface = 70 m²

Peso A/m kg	Press Alt ft	5 °C		NOT 15 °C		25 °C		35 °C	
		GRND ROLL m	DISTANCE 15 m OBS m	GRND ROLL m	DISTANCE 15 m OBS m	GRND ROLL m	DISTANCE 15 m OBS m	GRND ROLL m	DISTANCE 15 m OBS m
550	0	81	178	153	335	214	470	274	602
	1000	88	194	167	366	234	512	299	656
	2000	96	212	182	399	255	559	326	716
	3000	105	231	199	436	278	611	357	783

For towing banners whose surface is less than 90m², the maximum allowed take-off weight reaches 550kg.

RATE OF CLIMB

CONDITIONS:

- Flap: 0°
- Engine throttle: Full
- $V_Y = 53$ KIAS
- $OAT \leq 35^\circ$
- Airfield pressure altitude ≤ 3000 ft
- Banner's surface: **140** m²
- Take-off weight: **460** kg

The rate of climb is higher than **2** m/s.

CONDITIONS:

- Flap: 0°
- Engine throttle: Full
- $V_Y = 53$ KIAS
- $OAT \leq 35^\circ$
- Airfield pressure altitude ≤ 3000 ft
- Banner's surface ≤ 90 m²
- Take-off weight: **550** kg

The rate of climb is higher than **2** m/s.

2.7 WEIGHT & BALANCE**EQUIPMENT LIST**

In the following table are listed all the equipment that Tecnam has installed on the P92-JS for towing banners.

EQUIPMENT LIST		A/C S/N		DATE:	
REF.	DESCRIPTION & P/N	S/N	INST	WEIGHT kg	DATUM m
F1	Towing Hook assy		*	3.8	4.01
F2	Rear-view mirror 92-12-900-000		*	0.2	1.60

2.8 SYSTEMS

The P92-JS for towing banners is equipped with a hook located in the rear part of the fuselage. This hook is supported by a tubular beam [1] that transfers the towing loads to the tail cone structure. The forward part of the beam is connected to the bulkhead #4 by means of two vertical stringers [5-6] and two longitudinal stringers [7] (not present in the P92-JS standard configuration). The rear link to the bulkhead #5 is realised by a steel support [2] connected by means of two steel ties [4-3] to the stabilator's fitting plates. The hook is a TOST E85 and is connected to the aluminium tubular beam by means of aluminium plates.

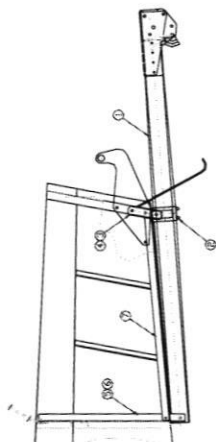

Supporting beam assembly

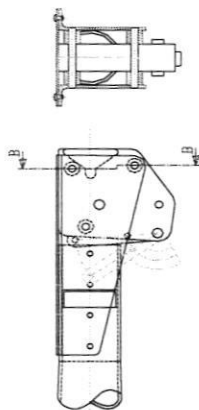

Hook connection

The towing rope is released by the Hook simply operating the release lever located in cabin between the two seats.

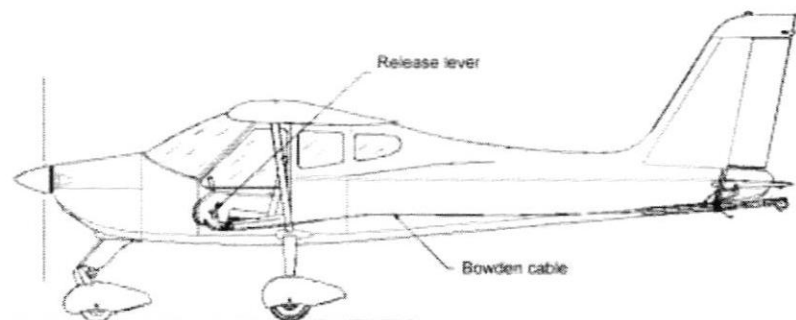

The towing hook is a TOST E85 approved type (Type Certificate No. 30.230/1)

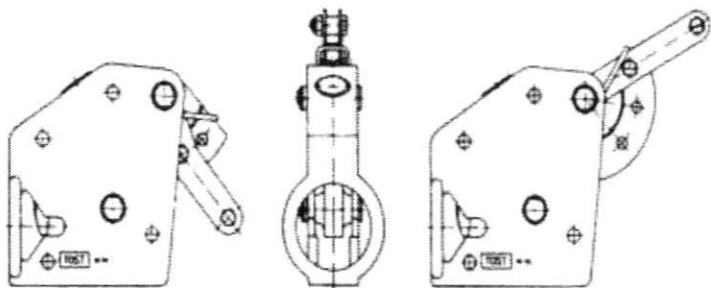

Hook TOST E85



For further information, please refer to the hook's "Operating Manual for tow releases"

On the left door, a rear view mirror is positioned to let the pilot to see the banner during towing.

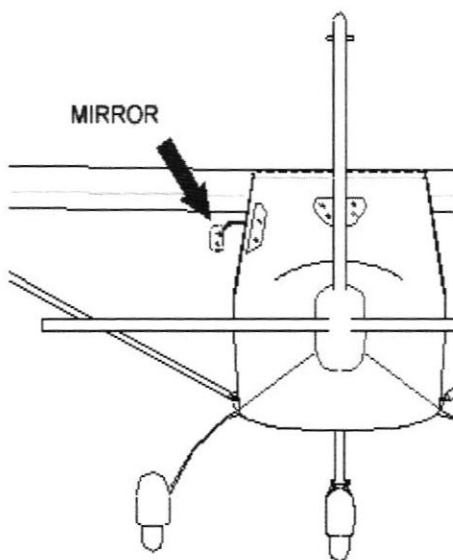

SUPPLEMENT N° 3

DIFFERENTIAL BRAKE SYSTEM

3 INTRODUCTION

This section contains supplementary information for safe and efficient operation of the aircraft if equipped with the differential brake system.

3.1 GENERAL

No variations.

3.2 LIMITATIONS

No variations.

3.3 EMERGENCY PROCEDURES

No variations.

3.4 NORMAL OPERATION

No variations.

3.5 PERFORMANCE

No variations.

3.6 WEIGHT AND BALANCE

No variations.

3.7 SYSTEMS

Figure 9-2 shows the brake system schematic diagram.

The left and right wheel brakes are independent systems. The system has a reservoir (4) visible from a little window on the baggage compartment. The reservoir is directly connected to the brake master cylinders (3). Two flexible hoses connect the master cylinders on the co-pilot's brake pedals to the master cylinders on the pilot's brake pedals.

The parking brake valve (6) is mounted on the floor of the fuselage, below the seats and it's activated by lever (2). Each main wheel has a brake disc (7).

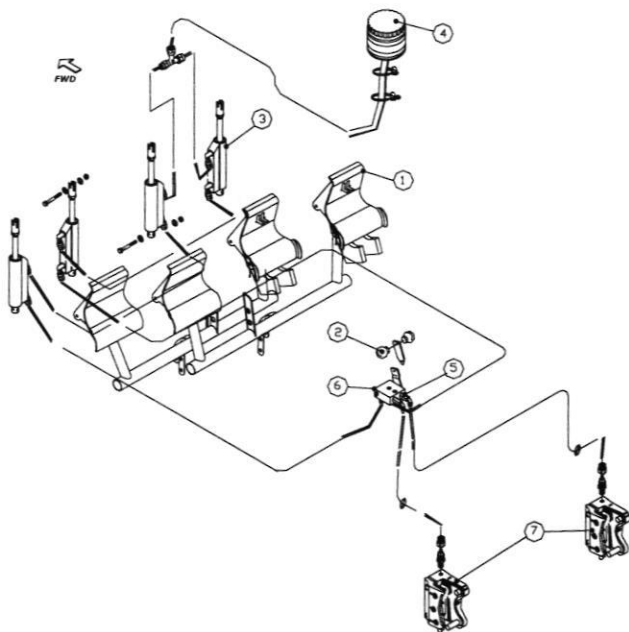

Figure 9-2 Differential brake system



The following placard is located on the central pedestal:

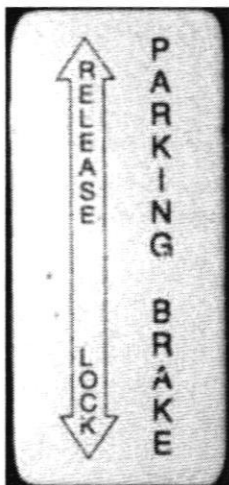

Figure 9-3 Parking brake placard

SUPPLEMENT N° 4
CENTRAL THROTTLE CONTROL SYSTEM

4 INTRODUCTION

This section contains supplementary information for safe and efficient operation of the aircraft if equipped with the central throttle control system.

4.1 GENERAL

No variations.

4.2 LIMITATIONS

No variations.

4.3 EMERGENCY PROCEDURES

No variations.

4.4 NORMAL OPERATION

No variations.

4.5 PERFORMANCE

No variations.

4.6 WEIGHT AND BALANCE

No variations.

4.7 SYSTEMS

The figures 9-3A and 9.3B show the central throttle control system when the Carb. Heat lever installed and only with central throttle lever.

The engine throttle lever is located on the left site and the choke lever is located on the right site.

The levers friction, for both configurations, is located on the lateral right site of the central throttle control system.

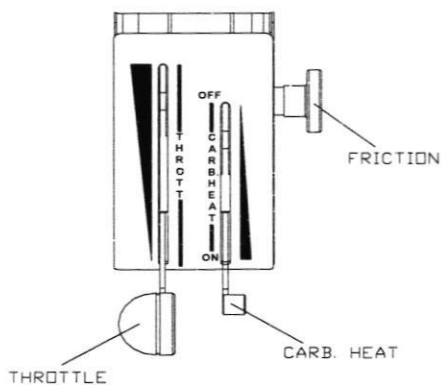

Figure 9-3A Central throttle control system with Carb. Heat control lever

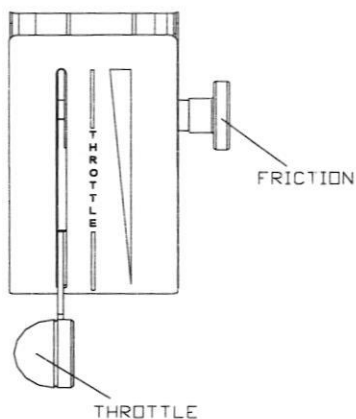

Figure 9-3B Central throttle control system

SUPPLEMENT N° 5
NEW ANALOGICAL INSTRUMENTS PANEL

5 INTRODUCTION

This section contains supplementary information for safe and efficient operation of the aircraft if equipped with the new analogical instruments panel.

5.2 GENERAL

No variations.

5.3 LIMITATIONS

No variations.

5.4 EMERGENCY PROCEDURES

No variations.

5.5 NORMAL OPERATION

No variations.

5.6 PERFORMANCE

No variations.

5.7 WEIGHT AND BALANCE

No variations.

5.8 SYSTEMS

The new analogical instruments panel is designed with a modular concept to improve the instruments visibility.

The new instruments panel is divided into three main parts. The left part with the flight instruments, central part with the avionic instruments and the right part with the engine instruments.

The following picture shown the new analogical instruments panel.

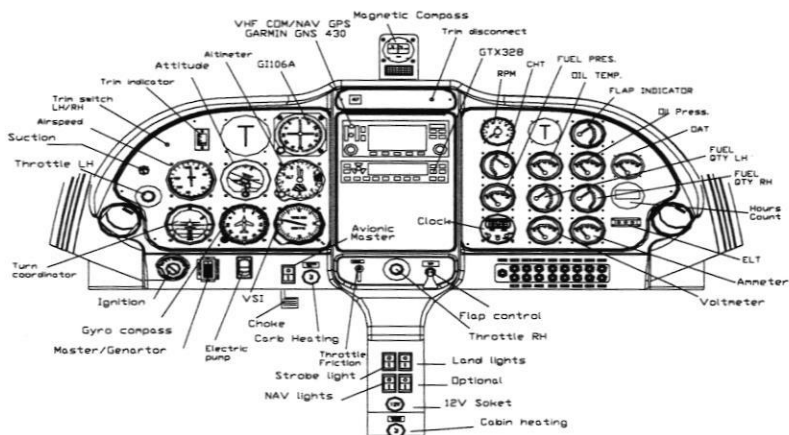

Figure 9-4



SUPPLEMENT N° 6
CHINESE AIRCRAFT FLIGHT MANUAL SUPPLEMENT

Record of Revisions

Rev	Revised page	Description of Revision	EASA Approval or Under DOA Privileges
0			DOA

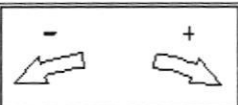
6 PLACARD IN CHINESE

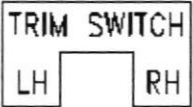
Placard	Chinese
<div style="border: 1px solid black; padding: 5px; text-align: center;"> THROTTLE </div>	油门
<div style="border: 1px solid black; padding: 5px; text-align: center;">  </div> <div style="border: 1px solid black; padding: 5px; text-align: center;"> THROTTLE LOCK </div>	油门锁
<div style="border: 1px solid black; padding: 5px; text-align: center;"> CABIN HEAT Pull-on </div>	客舱加热 拉开
<div style="border: 1px solid black; padding: 5px; text-align: center;"> CARB. HEAT Pull-on </div>	汽化器加热 拉开
<div style="border: 1px solid black; padding: 5px; text-align: center;"> TRIM DISCONNECT ON OFF </div>	调整片断开 开 关

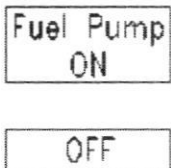
Placard	Chinese		
	调整片开关 左手 右手		
	开 主开关 发电机 关		
<table border="1" style="width: 100%;"> <tr> <td style="width: 50%;"> Left Tank Usable fuel 49.5 litres </td> <td style="width: 50%;"> Right Tank Usable fuel 49.5 litres </td> </tr> </table>	Left Tank Usable fuel 49.5 litres	Right Tank Usable fuel 49.5 litres	左油箱可用燃油量49.5升 右油箱 可用燃油量49.5升
Left Tank Usable fuel 49.5 litres	Right Tank Usable fuel 49.5 litres		
	油泵 开 关		
<table border="1" style="width: 100%;"> <tr> <td style="width: 50%;"> TIE-IN SWIVEL BRASSNESS MAX WEIGHT 20kg (44 lbs) MAX SPEC. PRESS: 12.5 kg/cm² (256 lbs/sq in) </td> <td style="width: 50%;"> RIGID LANE LIT ON/GHIF PESO WASSING 20kg MAX PRESS. SPEC: 12.5 kg/cm² </td> </tr> </table>	TIE-IN SWIVEL BRASSNESS MAX WEIGHT 20kg (44 lbs) MAX SPEC. PRESS: 12.5 kg/cm ² (256 lbs/sq in)	RIGID LANE LIT ON/GHIF PESO WASSING 20kg MAX PRESS. SPEC: 12.5 kg/cm ²	行李带系紧最大重量20kg 最大规定压力12.5kg
TIE-IN SWIVEL BRASSNESS MAX WEIGHT 20kg (44 lbs) MAX SPEC. PRESS: 12.5 kg/cm ² (256 lbs/sq in)	RIGID LANE LIT ON/GHIF PESO WASSING 20kg MAX PRESS. SPEC: 12.5 kg/cm ²		



Placard	Chinese		
<table border="1" style="width: 100%;"> <tr> <td style="width: 50%; text-align: center;"> AUTOMOTIVE FUEL LEADED OR UNLEADED AVGAS 100LL CAPACITY 50LT (13.2 US gal.) </td> <td style="width: 50%; text-align: center;"> AUTOMOTIVE FUEL LEADED OR UNLEADED AVGAS 100LL CAPACITY 50LT (13.2 US gal.) </td> </tr> </table>	AUTOMOTIVE FUEL LEADED OR UNLEADED AVGAS 100LL CAPACITY 50LT (13.2 US gal.)	AUTOMOTIVE FUEL LEADED OR UNLEADED AVGAS 100LL CAPACITY 50LT (13.2 US gal.)	<p style="text-align: center;">汽车燃油含铅不含铅 航油 100低铅，容量50升</p> <p style="text-align: center;">汽车燃油含铅不含铅 航油 100低铅，容量50升</p>
AUTOMOTIVE FUEL LEADED OR UNLEADED AVGAS 100LL CAPACITY 50LT (13.2 US gal.)	AUTOMOTIVE FUEL LEADED OR UNLEADED AVGAS 100LL CAPACITY 50LT (13.2 US gal.)		
<table border="1" style="width: 100%;"> <tr> <td style="width: 50%; text-align: center;"> AUTOMOTIVE OIL APL "SF" OR "SG" </td> <td style="width: 50%; text-align: center;"> AUTOMOTIVE OIL CAPACITY 3.5 LT </td> </tr> </table>	AUTOMOTIVE OIL APL "SF" OR "SG"	AUTOMOTIVE OIL CAPACITY 3.5 LT	<p style="text-align: center;">机动滑油 APL "SF" or "SG" 机动滑油 容量3.5升</p>
AUTOMOTIVE OIL APL "SF" OR "SG"	AUTOMOTIVE OIL CAPACITY 3.5 LT		
<div style="border: 1px solid black; padding: 5px; display: inline-block;">BATTERY INSIDE</div>	<p style="font-size: 1.2em;">内装蓄电池</p>		
<div style="border: 1px solid black; padding: 5px; display: inline-block;"> EXTERNAL POWER RECEPTACLE 12 Volt - DC </div>	<p style="font-size: 1.2em;">外接电源插头 12伏 - 直流</p>		
<div style="border: 1px solid black; padding: 5px; display: inline-block;"> FIRE EXTINGUISHER ON BAGGAGE FLOOR </div>	<p style="font-size: 1.2em;">灭火器在行李舱地板上</p>		
<div style="border: 1px solid black; padding: 5px; display: inline-block;"> <i>No smoking</i> </div>	<p style="font-size: 1.2em;">禁止吸烟</p>		
<div style="border: 1px solid black; padding: 5px; display: inline-block;">NO STEP</div>	<p style="font-size: 1.2em;">请勿踩踏</p>		
<table border="1" style="width: 100%;"> <tr> <td style="text-align: center;"> Maneuvering speed Va=93 KIAS </td> </tr> <tr> <td style="text-align: center;"> Maneuvering speed Va=97 KIAS </td> </tr> </table> <p style="font-size: 0.8em;">Note: Va=97 Kias when the weight increment to 600 Kg is applied</p>	Maneuvering speed Va=93 KIAS	Maneuvering speed Va=97 KIAS	<p style="font-size: 1.2em;">机动速度VA=93 KIAS</p> <p style="font-size: 1.2em;">机动速度VA=97 KIAS</p>
Maneuvering speed Va=93 KIAS			
Maneuvering speed Va=97 KIAS			



SUPPLEMENT N° 7
ARGENTINA AIRCRAFT FLIGHT MANUAL SUPPLEMENT

Record of Revisions

Rev	Revised page	Description of Revision	EASA Approval or Under DOA Privileges
0			DOA

7 INTRODUCTION

This section contains supplementary information for a safe and efficient operation of the aircraft delivered in the Argentina.

7.2 GENERAL

No variations, refer to basic AFM.

7.3 LIMITATIONS

Section 2 includes additional operating limitations, instrument markings, and basic placards necessary.

WARNING: Limitations, operation under Normal and Emergency Procedures & Performances associated to 600 Kg MTOW are only applicable for Aircraft which embody the design change MOD 92/41, or apply Service Bulletin SB 011-CS as retrofit .

7.3.1 FUEL

APPROVED FUEL

MOGAS ASTM D4814
AVGAS 100L (ASTM D910)

7.3.2 REQUIRED EQUIPMENT

The airplane, in standard configuration, is approved only for day VFR operation with terrain visual contact.

In addition to KOEL, listed in the basic manual, the appropriate equipment for different types of operation must comply with the applicable Argentine Operational Regulations (RAAC).

7.3.3 LIMITATION PLACARDS

On the left hand of the dashboard a placard will state the following:

NO FUMAR

Near baggage compartment a placard will state the following:

**ASEGURAR LA RED
PESO MÁXIMO 20 Kg
MÁXIMA PRESIÓN 12,5
Kg/dm²**

7.4 EMERGENCY PROCEDURES

No variations, refer to basic AFM.

7.5 NORMAL OPERATION

No variations, refer to basic AFM.

7.6 PERFORMANCE

No variations, refer to basic AFM.

7.7 WEIGHT AND BALANCE

No variations, refer to basic AFM.

7.8 AIRCRAFT & SYSTEMS DESCRIPTION

A placard measuring 74x7 mm is located on the instrument panel to indicate fire extinguisher position:

EXTINTOR DE INCENDIO EN
EL PISO DEL COMPARTIMIENTO DE
EQUIPAJE

The following placard is located in proximity of fuel filler caps (28x63 mm):

MOGAS ASTM D4814
AVGAS 100LL (ASTM D910)
CAPACIDAD 45 Lt (11,9 US gal)

The following label is located below each door for emergency opening (Cabin doors external aft side):



EN CASO DE EMERGENCIA
TOME LA MANIJA Y
TIRE CON FUERZA DE AQUÍ.

EN CASO DE EMERGENCIA
TOME LA MANIJA Y
TIRE CON FUERZA DE AQUÍ.



On the right side of the tail cone, on the power receptacle's door is present the following placard (135x25 mm)

CONEXIÓN DE ENERGÍA EXTERNA
12 VOLT - DC

On the right side of the tail cone, next to the battery case access door, is present the following placard (69x17 mm)

BATERÍA ADENTRO

On both the main landing gear fairings the following placard (120x22 mm) is present.

NO PISAR