

MAINTENANCE MANUAL

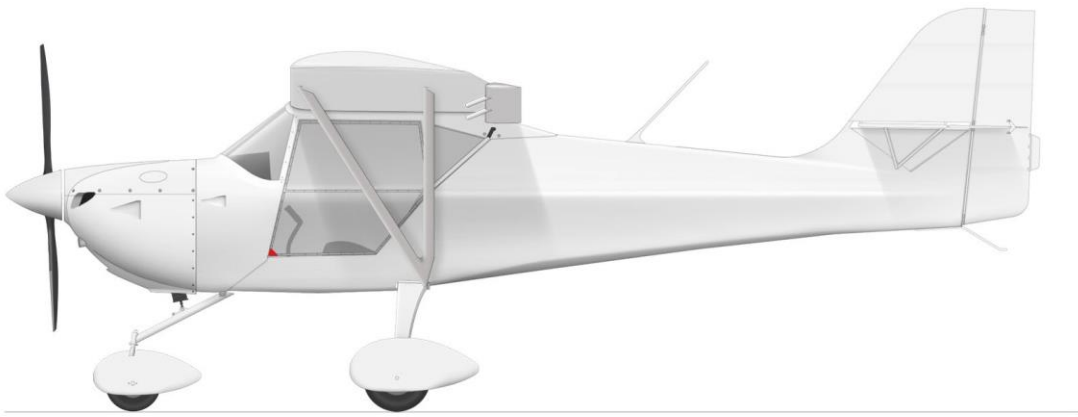

AEROPRO
EuroFOX 3K

Issued: July 15. 2024



List of effective pages

Insert latest changed pages. Destroy superseded pages.

Note: Changed pages are indicated by the marking “changed” at the bottom of the page.

Dates of issue for original and changed pages are:

Original: December 7. 2009

Total number of pages in this publication is: 166 consisting of the following:

Page No.	Change No.
Title	0
0-1 thru 0-4	0
1-1 thru 1-11	0
2-1 thru 2-17	0
3-1 thru 3-10	0
4-1 thru 4-8	0
5-1 thru 5-15	0
6-1 thru 6-7	0
7-1 thru 7-4	0
8-1 thru 8-4	0
9-1 thru 9-4	0
10-1 thru 10-27	0
11-1 thru 11-8	0
12-1 thru 12-3	0
13-1 thru 13-3	0
14-1 thru 14-10	0
15-1 thru 15-12	0
16-1 thru 16-2	0
17-1 thru 17-1	0
18-1 thru 18-5	0
19-1 thru 19-2	0

Upon receipt of the second and subsequent changes to this book, personal responsible for maintaining this publication in current status should ascertain that all previous changes have been received and incorporated.

Table of content

<u>Section</u>		
<u>Page</u>		
1	General description	1-1
2	Ground handling, servicing, lubrication and inspection	2-1
3	Structures – Fuselage	3-1
4	Structures – Wings and empennage	4-1
5	Structures – Landing gear and brakes	5-1
6	Structures – Aileron and flap control system	6-1
7	Structures – Elevator control system	7-1
8	Structures – Elevator trim control system	8-1
9	Structures – Rudder control system	9-1
10	Engine	10-1
11	Fuel system	11-1
12	Propeller	12-1
13	Utility systems	13-1
14	Instruments and instrument system	14-1
15	Electrical systems	15-1
16	Structural repair	16-1
17	Exterior painting	17-1
18	Wiring diagramms	18-1
19	Safety directives and safety monitoring system	20-1

Foreword

This maintenance manual contains factory-recommended procedures and instructions for the ground handling, servicing and maintaining of the EuroFOX Series aircraft. Besides serving as a reference for an experienced mechanic, this manual also covers step-by-step procedures for the less experienced person. This manual should be kept in a handy place for ready reference. If properly used, it will better enable the mechanic to maintain the EuroFOX Series aircraft and thereby establish a reputation for reliable service.

All information contained is based on data available at the time of publication and is supplemented and kept current by service bulletins published by the Aeropro Company. These bulletins are sent to all EuroFOX Aircraft Dealers so that they have the latest authoritative recommendations for servicing EuroFOX aircraft. Therefore it is recommended that EuroFOX owners utilize the knowledge and experience of the factory-trained Dealer Service.

Common conversions and abbreviations

Units of length	1 mm	= 0.03937 in
	1 in	= 25.4 mm
	1 ft	= 0.3048 m
<hr/>		
Units of area	1 cm ²	= 0.155 sq in
	1 sq in	= 6.4516 cm ²
<hr/>		
Units of volume	1 cm ³	= 0.06102 cu in
	1 cu in	= 16.3871 cm ³
	1 gal (US)	= 3.7854 l (dm ³)
<hr/>		
Units of mass	1 kg	= 2.2046 lb
	1 lb	= 0.45359 kg
<hr/>		
Units of force	1 N	= 0.224809 lbf
	1 lbf	= 4.4482 N
<hr/>		
Units of pressure	1 bar	= 1000 hPa
	1 bar	= 14.5037 lbf/in ² (psi)
	1 lbf/in ² (psi)	= 0.0689 bar
	1 in HG	= 33.8638 hPa
<hr/>		
Units of temperature	°C	= (°F – 32) / 1.8
	°F	= (°C x 1.8) + 32
<hr/>		
Velocities	1 m/s	= 3.6 kph
	1 ft/min	= 18.288 m/s
	1 m/s	= 0.0555 ft/min
	1 kts	= 1.852 kph
	1 kph	= 0.53996 kts
<hr/>		
Torques	1 Nm	= 8.848 In.lb.
	1 in.lb.	= 0.113 Nm
	1 ft.lb.	= 1.356 Nm

Section 1

General Description

Table of contents	Page
1.1 General description.....	1-1
1.2 Description.....	1-1
1.3 Aircraft specifications.....	1-1
1.4 Torque values.....	1-2
1.5 Tire inflation pressures.....	1-3
1.6 Approved oils and capacities.....	1-3
1.7 Engine specifications.....	1-4
1.8 Equipment list.....	1-6
1.9 Weight and balance information.....	1-6
1.9.1 Center of gravity determination.....	1-6
1.9.2 CG-calculation.....	1-7
1.10 Sources to purchase parts.....	1-9
1.11 Disposable replacement parts.....	1-9
1.12 General safety information.....	1-10
1.13 Reporting possible safety of flight concerns during inspection	1-11

1.1 General description

1.2 Description

The EuroFOX aircraft, as described in this manual, is a conventional highwing aircraft. The main supporting structure of the fuselage is of lattice-work welded of steel tubes. The aircraft is equipped with a fixed tricycle landing gear with a steerable nose wheel. A two place, side by side seating configuration is standard. Each aircraft is equipped with a 4-stroke, four-cylinder, horizontally-opposed, water cooled Rotax 915 iS aluminium alloy engine, driving a fixed pitch DUC FLASH-3 propeller.

1.3 Aircraft specifications

Primary specifications of the aircraft, with dimensions based on gross weight, are given in figure 1-1. If these dimensions are used for constructing a hangar or computing clearances, remember that such factors as tire pressure or load distributions may result in some dimensions that are somewhat different from those listed.

Figure 1-1.

Gross weight (in Australia)	560 Kg
Fuel capacity.....	84 liters.
Oil capacity.....	3 liters.
Engine model (Refer to Section 11 for Engine Data).....	Rotax 915 iS2 A
Propeller (Variable Pitch).....	1850 DUC FLASH-3
Main wheel tires.....	8-8.00-6
Pressure.....	1.0 bar
Nose wheel tire.....	15-6.00-6
Pressure.....	1.0 bar
Aileron travel	
Up.....	18°, +/- 2°
Down.....	8.5°, +/- 1°
Wing flap travel.....	0° to 20°, +/- 2°
Rudder travel	
Right.....	27°, +/- 2°
Left.....	27°, +/- 2°
Elevator travel	
Up.....	30°, +/- 2°
Down.....	27°, +/- 2°
Elevator trim tab travel	
Up.....	30°, +/- 3°
Down.....	30°, +/- 3°
Principal dimensions	
Wing span.....	29.9'
Length with carbon spinner.....	18.5'
Vertical stabilizer height.....	7.3'
Track width.....	4.5'
Tail span.....	7.8'
Battery location.....	right site

1.4 Torque values

A Chart of recommended nut torque values is shown in figure 1-2. These torque values are recommended for all installation procedures contained in this manual, except where other values are stated. They are not to be used for checking tightness of installed parts during service.

Figure 1-2.

M4.....	4 Nm / 35 in.lb.
M5.....	6 Nm / 53 in.lb.
M6.....	10 Nm / 88 in.lb.
M8.....	24 Nm / 212 in.lb.
M10.....	35 Nm / 310 in.lb.

Caution
Do not re-use self-locking nuts

1.5 Tire inflation pressure

Maintain tire pressure at the air pressures specified in figure 1-1. When checking the tire pressure, examine the tires for wear, cuts, bruises and leakage. Remove oil, grease and mud from the tires with soap and water.

1.6 Approved oils and capacities

In general we recommend referring to the latest Rotax 915 iS engine operators manual to check for a suitable engine oil. Nevertheless, general recommendations about lubricants are shown in figure 1-3.

Caution	If the engine is mainly run on AVGAS more frequent oil changes will be required. See Rotax Service Information SI-18-1997, latest edition. When selecting suitable lubricants also refer to the Rotax Service Information SI-18-1997 latest edition. The use of multi-grade oils is recommended. Multi-viscosity grade oils are less sensitive to temperature variations than single-grade oils. They are suitable for use in all seasons. Ensure rapid lubrication of all engine components during a cold start and multiviscosity oils get less fluid at higher temperatures.
----------------	---

Figure 1-3.

Oil specification
Use motorcycle oil of a registered brand with gear additives. No aircraft engine oil should be used.
<ul style="list-style-type: none">- Use only oil with API classification "SF" or "SG"- Due to high stresses in the reduction gears, oils with gear additives such as high performance motorcycle oils are required.
<ul style="list-style-type: none">- Because of the friction clutch incorporated in the gearbox, oils with friction modifier additives are unsuitable as this could result in a slipping clutch during normal operation.- Heavy duty 4-stroke motorcycle oils meet all the requirements. These oils are normally not mineral oils but semi- or fully-synthetic oils.- Oils primarily for diesel engines are generally unsuitable due to insufficient high temperature properties and additives which favor clutch slipping.

Table of lubricants

Since the temperature range of neighboring SAE grades overlap, there is no need to change the oil viscosity used for a short duration flight with ambient temperature fluctuations.

Climatic conditions

Multi-grade oils

Tropical	SAE 20W-50, SAE 20W-40 SAE 15W-50, SAE 15W-40 SAE 10W-40 SAE 5W-50, SAE 5W-40
Temperate	SAE 20W-50, SAE 20W-40 SAE 15W-50, SAE 15W-40 SAE 10W-40 SAE 5W-50, SAE 5W-40
Arctic	SAE 10W-40 SAE 5W-50, SAE 5W-40

1.7 Engine specifications

The Rotax 915 iS engines are 4-stroke, 4 cylinder horizontally opposed, spark engines with electrical injection, featuring one central camshaft with push rods – OHV. The cylinder heads are liquid cooled. The lubrication system is a dry sump forced type. It is equipped with TBO, fuel pump box, fuse box and 2 ECU units. The prop drive is via reduction gear with integrated shock absorber and overload clutch. Specific engine datas are given in **figure 1-4**.

Figure 1-4.

Description	915 iS2 A
Dimensions	
Bore.....	84mm
Stroke.....	61 mm
Displacement.....	1352 mm ³
Compression ratio.....	10.8 : 1
Weight (without exhaust, radiator, air intake system)....	134 lb
Speed	
Takeoff speed.....	5,800 rpm
Continuous speed (max.).....	5,500 rpm
Idle speed (approx.).....	1,700 rpm
Gear ratio.....	2.43 :1
Performance	
Takeoff performance.....	141 hp
Continuous performance.....	135 hp
Acceleration	
Max. negative "g" for 5 seconds.....	-0.5 g
Oil pressure	
Max. for short period at cold start.....	7 bar
Min. (below 3500 rpm).....	0,8 bar
Normal (above 3500 rpm).....	2,0 – 5,0 bar
Deviation at max bank angle	40°
Oil temperature	
Max.....	130° C
Min.....	50° C
Normal.....	90 - 110° C
Coolant temperature	
Max. (observation at hottest cylinder, #2 or #3)...	120° C
Normal.....	70 - 110°C
Engine start, operating temperature	
Max.....	50° C
Min.....	-25° C
Fuel pressure	
Max.....	3,2 bar
Min.....	2.8 bar
Electric starter	
Generator.....	12V, 0.6 kw
	12V, 20A

1.8 Equipment list

In figure 1-5 a list of the factory installed equipment is provided. Additionally installed equipment and alterations have to be considered when performing the weight and balance calculation. If a ballistic recovery system is installed from the factory, this is already included in the factory weight and balance calculation form.

**Figure 1-5.
Factory installed equipment**

Airspeed indicator, Altimeter, Vertical speed indicator, Compass, RPM gauge (EIS) Oil pressure gauge (EIS) Oil temperature gauge (EIS) CHT gauge (EIS) Exhaust gas temperature gauge (EIS) Position lights Master, avionics and engine kill (ignition) switches Electrical system including circuit breakers 4-Point safety belts (pilot and passenger) Ballistic recovery system (optional factory equipment)
--

1.9 Weight and balance information

To perform a successful weight and balance calculation, the center of gravity "C.G." has to be determined with all the installed equipment, including engine oil, cooling liquid being considered, but without fuel. Figure 1-6. shows how to conduct the C.G. determination. All measurements including a listing of all the installed equipment has to be noted in the separate weight and balance calculation form (an example is given in figure 1-7.). This form has to be placed in the aircraft, so every pilot will be able to conduct his specific weight and balance calculation prior to each flight.

1.9.1 Center of gravity determination

To get the correct values, it is necessary to put the aircraft on three weighing scales located on a level surface. Before conducting the weighing procedure, it is important to achieve a level wing main chord, outlined as "Reference Line R.L." in figure 1-6. (use suitable pads between main wheels and scale beneath to hoist aircraft). A check-mark ("Reference Point R.P." in figure 1-6.) on the leading edge of the left wing, adjacent to the wing root is provided to ease examination that wing main chord is level (check-mark and trailing edge has to be level) - use a flexible clear tube, filled with water as spirit level. To get the total weight G you have to add weight G1 and G2. The center of gravity has to be calculated using this value. The C.G. is located at the distance (X) behind R.P. (leading edge check-mark) near the fuselage (see figure 1-6.).

1.9.2 CG - calculation

A specific C.G.-calculation recommendation which has to be carried out prior to each flight is provided in the Pilot Operating Handbook, Section 4.

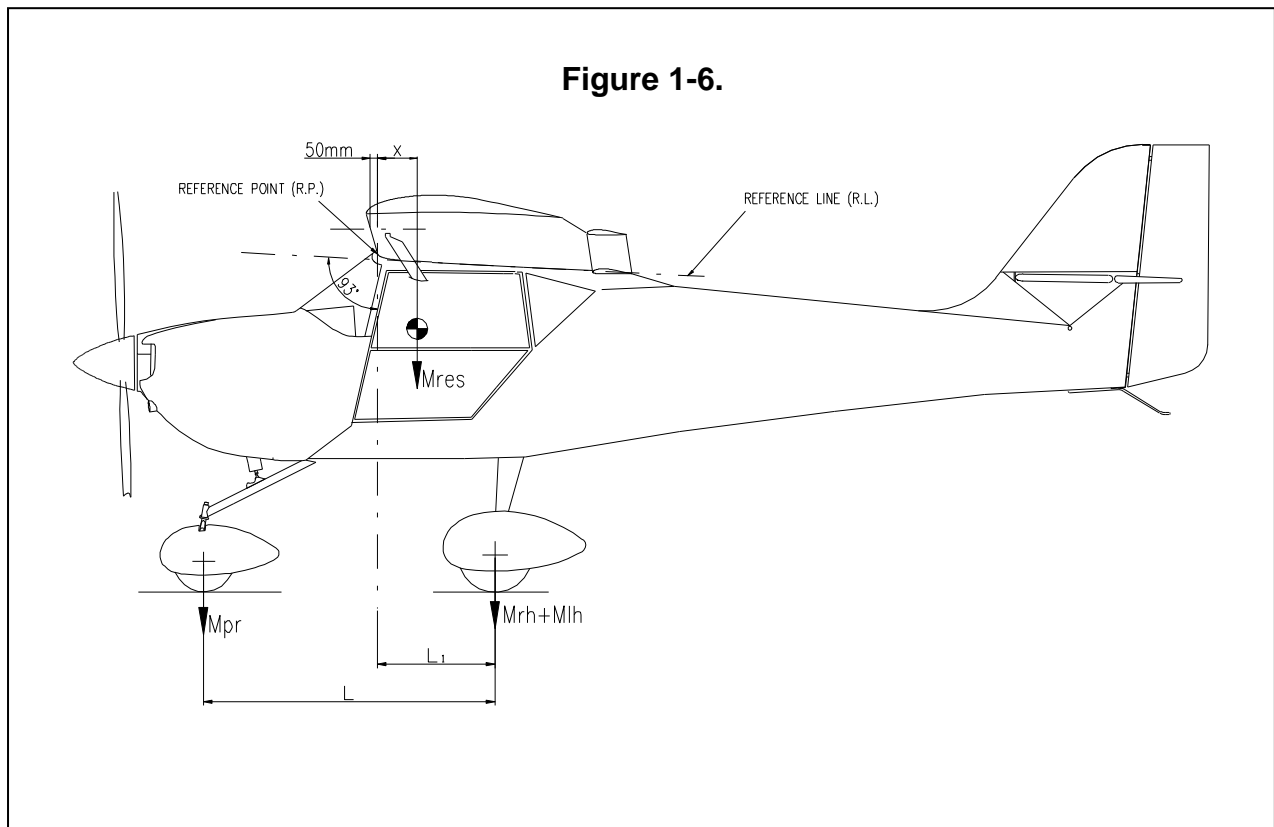

Figure 1-7.

Weight and C.G. Position Record (specimen)			
Serial Number	66222	Registr. Mark:	4X-HNG
Aircraft Levelling:			
Values Weighed:			
Main wheels	right-hand	Mrh =	146,0 kg
	left-hand	Mlh =	144,0 kg
Nose wheel		Mpr =	59,1 kg
		L =	1435 mm
		L1 =	506 mm
Resulting weight		Mres =	349,1 kg
C.G. position			
		$B = (M_{pr} \times L) / M_{res} =$	242,9 [mm]
		$X = L_1 - B + 50 =$	313,06 [mm]
		$\bar{X} = (X \times 100) / 1300 =$	24,15 [%MAC]
Date:	Performed by:		

1.10 Sources to purchase parts

In figure 1-8. sources to purchase spare parts and disposable parts are given. When in doubt, ask your distributor or contact the factory first.

Figure 1-8.

Part description	Sources
<i>Airframe and Engine Components...</i>	Aeropro s.r.o. Hlavní 439, 68725 Hluk Czech republic Phone: (+421) 376526355 Fax: (+421) 376526355 e-mail: info@aeropro.sk Web: www.aeropro.cz
<i>Engine Components.....</i>	Refer to ROTAX Engine Operator's Manual 915 Series

Figure 1-9.

Part description or location	Part description
<i>Engine Compartment.....</i>	Oil filter element Gasket for oil filter Gasket for oil drain screw Air cleaner element All gaskets in general Exhaust system Retaining springs Self-locking nuts in general

	Propeller screws
	Engine mount screws
	Engine shock mounts
	Throttle control cables
Other specific Engine Components.....	Refer to Rotax Engine Maintenance Manual.
Propeller.....	Refer to DUC Operators Manual
Landing gear.....	Tires and tubes
	Cotter pins in general
	Hydraulic line fittings
	Self-locking nuts in general
	Brake pads
	Brake discs
	All wheel and landing gear Components when damaged in general.
Airframe.....	Self-locking nuts in general
	Cotter pins in general

1.11 Disposable replacement parts

A listing of disposable replacement parts which require replacement at regular servicing intervals is given in figure 1-9. Details of where to purchase replacement parts is shown in figure 1-8. When damage is found on any part of the aircraft please contact your AEROPRO distributor when in any doubt about replacement or repair. No repairs must be done to any of the listed parts due to flight safety!

1.12 General safety information

This aircraft should never be operated at locations, airspeeds, altitudes or other circumstances from which a successful no-power landing cannot be made, after sudden engine stoppage. This aircraft must only be flown at VFR (daylight) conditions and it is not suitable for acrobatics.

Whether you are a qualified pilot or a novice, complete knowledge of the aircraft, its controls and operation is mandatory before venturing solo. Flying any type of aircraft involves a certain amount of risk. Be informed and prepared for any potentially hazardous situation associated with flying.

A recognized training program and continued education for piloting an aircraft is absolutely necessary for all aircraft pilots. Make sure you also obtain as much information as possible about your aircraft, its maintenance and operation from your dealer.

Respect all government or local rules pertaining to flight operation in your flying area. Fly only when and where conditions, topography and airspeeds are safest and legal. Select and use proper aircraft instrumentation -- only approved instrumentation may be installed.

Before flight, ensure that all engine controls are operative. Make sure all controls can be easily reached in case of emergency.

Unless in a suitable run up area, never run the engine with the propeller turning while on the ground. Do not operate engine if bystanders are close. In the interest of safety, the aircraft must not be left unattended while the engine is running.

Keep an aircraft log and respect engine and aircraft maintenance schedules. Keep the engine in top operating condition at all the times. Do not operate any aircraft which is not properly maintained or has engine operating irregularities which have not been corrected.

Since special tools, equipment and certification may be required, servicing should only be performed by repairmen specified in this manual.

To eliminate possible injury or damage, ensure any loose equipment or tools are properly secured before starting the engine.

When in storage, protect the engine and fuel system from contamination and exposure.

Certain areas, altitudes and conditions present greater risk than others.

Never operate the engine and gearbox without sufficient quantities of lubricating oil. Periodically verify level of coolant.

Never exceed maximum rated rpm. Allow the engine to cool at idle for several minutes before turning off.

1.13 Reporting possible Safety of flight concerns during inspection

If any concerns about safety of flight are found during inspection or maintenance this must be reported in the inspection form (refer to Section 2). If in doubt about the airworthiness of the aircraft, it is strongly recommended to contact your AEROPRO distributor. The aircraft must not be flown unless concerns about flight safety are resolved completely.

Section 2

Ground handling, servicing, lubrication and inspection

Table of contents		Page
2.1	Ground handling.....	2-0
2.2	Towing the aircraft.....	2-1
2.3	Hoisting.....	2-1
2.4	Jacking.....	2-1
2.5	Parking.....	2-1
2.6	Tie-down.....	2-2
2.7	Flyable storage.....	2-2
2.8	Returning aircraft to service.....	2-2
2.9	Temporary storage.....	2-3
2.10	Inspection during storage.....	2-3
2.11	Returning aircraft to service.....	2-3
2.12	Servicing.....	2-4
2.13	Fuel.....	2-4
2.14	Fuel drains.....	2-4
2.15	Engine oil.....	2-4
2.16	Engine induction air filter.....	2-4
2.17	Battery.....	2-5
2.18	Tires.....	2-5
2.19	Hydraulic brake system.....	2-9
2.20	Cleaning.....	2-9
2.21	Windshield and windows.....	2-9
2.22	Plastic trim.....	2-10
2.23	Painted surfaces.....	2-10
2.24	Aluminum surfaces.....	2-10
2.25	Engine and engine compartment.....	2-10
2.26	Upholstery and interior.....	2-11
2.27	Propeller.....	2-11
2.28	Wheels.....	2-11
2.29	Lubrication.....	2-11
2.30	Inspection.....	2-12
I.	Inspection requirements.....	2-12
II.	Inspection charts.....	2-12
III.	Inspection guide lines.....	2-13

2.1 Ground Handling

2.2 Towing the aircraft

Moving the aircraft by hand is done by using the wing struts and landing gear struts as push points. Since there is no tow bar applicable at the nose gear, you have to press down and hold on the left side of fuselage adjacent to the fin to raise the nose wheel off the ground. With the nose wheel clear of ground, the aircraft can be turned by pivoting it about the main wheels.

2.3 Hoisting

The aircraft may be lifted by points designed for this purpose - the aircraft rear section may be lifted by hand by use of the grip rail on the left side of the fuselage, or by the underside of the rear fuselage lattice-work, preferably by use of tube gussets if possible, so that the fuselage part being lifted can be supported with a soft pad on the lattice-work tubes of the fuselage, or on a stand under the tail-wheel landing gear. The aircraft must be chocked on all wheel to prevent any undesirable movement. Load relief of landing gear one side. To relieve the load on one side of the landing gear, lift that side of the aircraft by the wing strut attachments points to the required height. This method cannot be applied for a long-term aircraft supporting, it may be used for a momentary, short-term lifting of the aircraft only. When jacking the whole of the aircraft firstly make ready a block padded on one side with a soft material. We will use this block to support transversely the front part of the fuselage and, using two jacks, jack the aircraft fuselage up to the required height. Furthermore, prepare a fixing stand to be located underneath the aircraft, thus assuring stable support and positioning for the whole aircraft. To jack-up the aircraft, you can also use special jacking stands designed for large aircraft if the size and frame configurations are appropriate.

2.4 Jacking

Refer to paragraph 2.3. The aircraft does not feature further jacking points except for changing main wheels. Doing so requires one person to lift the aircraft by pushing up at the points where the struts connect to the wing, while a second person has to put a jack beneath the main wheel axle. A piece of foam must be inserted between the jack and the wheel axle so that no damage will occur to the paint.

2.5 Parking

Parking precautions depend principally on local conditions. As a general precaution, apply the parking brake or chock the wheels and lock the controls. It is often found a safe precaution to tie down the aircraft as outlined in paragraph 2.6. if a hangar is not available even in weather not deemed a threat to the aircraft. Weather conditions often change rapidly and many aircraft have been saved by the use of tie downs.

Caution

Do not apply the parking brakes during cold weather (when accumulated moisture may freeze the brakes) or when brakes are overheated.

2.6 Tie-down

When parking the aircraft in the open, point the aircraft into wind if possible. Secure control surfaces by using suitable locks or clamps and set brakes.

After completing this procedure, proceed to tie the aircraft down as follows:

Tie ropes to the wing tie-down fittings (strut-wing attachment point). Secure the opposite ends of ropes to the ground anchors.

Secure a tie-down rope (no chains or cables) to the exposed propeller shaft (between the cowling and the spinner) and secure the opposite end of the rope to a ground anchor.

Secure the middle of a rope to the tail tie-down ring. Pull each end of rope away at a 45-degree angle and secure to ground anchors at each side of tail.

Secure controls to the rearward position by using the seat belts.

2.7 Flyable storage

Flyable storage is defined as a maximum duration of 30 days non-operational storage and/or the first 20 hours of intermittent engine operation.

During the 30 day non-operational storage or the first 20 hours of intermittent engine operation, every seventh day the propeller should be rotated through 10 revolutions, without running the engine. If the aircraft is stored outside, tie-down in accordance with paragraph 2.6. In addition, the pitot tube, static airvents, air vents, openings in the engine cowling, and or similar openings should all have protective covers installed to prevent entry of any foreign material. After 30 days, aircraft should be flown for 30 minutes or ground run-up until oil has reached operating temperature.

2.8 Returning aircraft to service

After flyable storage, returning the aircraft to service is accomplished by performing a thorough pre-flight inspection. At the end of the first 25 hours of engine operation, drain engine oil and replace external oil filter element. Service engine with correct grade and quantity of engine oil. Refer to figure 1-3. and paragraph 1.6 for correct grade of engine oil.

2.9 Temporary storage

Temporary storage is defined as an aircraft in a non-operational status for a maximum duration of 90 days. The aircraft is made from metal material, composite materials and a fabric surface. This construction will allow the aircraft to be stored for long periods of time without damage to the airframe. Nevertheless we recommend to store the aircraft in a dry hanger to keep paintwork and metal parts in good condition. For storage periods not exceeding 90 days, the following methods of treatment are suggested:

- a. Fill fuel tank with correct grade of gasoline.
- b. Clean and wax aircraft thoroughly.
- c. Clean any oil or grease from tires and coat tires with a tire preservative.
Cover tires to protect against grease and oil.
- d. Rotate wheels every 30 days to change supporting points and prevent flat spotting the tires.
- e. Seal or cover all openings which could allow moisture and/or dust to enter.
- f. Remove battery (see paragraph 15.17) and store in a cool dry place, charge battery as required.
- g. Seal all engine openings exposed to the atmosphere using suitable plugs or none-hygroscopic tape. Attach a red streamer at each point that a plug or tape is installed.
- h. If the aircraft is to be stored outside, perform the procedures outlined in paragraph 2.6. In addition, the pitot tube, static ports, air vents, openings in the engine cowling and other similar openings should have protective covers installed to prevent entry of foreign material.
- i. Attach a warning placard to the propeller to the effect that the propeller should not be moved while the engine is in storage state.

2.10 Inspection during storage

Remove dust accumulations from airframe as frequently as possible, clean and wax as required.

2.11 Returning aircraft to service

After temporary storage, use the following procedures to return aircraft to service:

- a. Check tires for proper inflation.
- b. Check battery and install.
- c. Check the oil sump has proper quantity of engine oil (Refer to Pilot Operating Handbook and/or Rotax Operator's Manual for instructions).
- d. Service induction air filter and remove warning placard from propeller.
- e. Remove materials used to cover openings.
- f. Check fuel tank and fuel lines for moisture and sediment, drain enough fuel to eliminate any possible moisture and sediment within the fuel system.
- g. Perform a thorough pre-flight inspection, then start and warm-up engine.

2.12 Servicing

Servicing requirements are shown in figure 2-2. The following paragraphs supplement this figure by adding details not included in the figure.

2.13 Fuel

Fuel tank should be filled immediately after flight to lessen moisture condensation. Tank capacity is listed in Section 1. The recommended fuel grade to be used is given in figure 2-2.

2.14 Fuel drains

A fuel drain is located at the bottom of the fuselage. The drain valve is accessed from beneath the fuselage adjacent to the main left-hand undercarriage leg. To activate the drain, push the metal tube upwards. Fuel can be continuously drained from the tank by activating the lock mechanism by pulling the metal tube downwards until it locks.

2.15 Engine oil

To check the engine oil, use the oil dipstick located in the oil tank on the right hand side of the firewall. The level should be checked immediately after the engine has been stopped and the propeller turned in the operational direction until a bubbling noise can be heard from the oil expansion tank.

Caution

PLEASE ENSURE THAT THE IGNITION SWITCHES ARE OFF AND THE KEY IS REMOVED BEFORE TURNING THE PROPELLER!

This is the only way to check the engine oil level correctly. (Refer also to the ROTAX Engine Operator's Manual).

Engine oil should be drained while the engine is still hot so that more positive draining is obtained. Refer to the inspection charts for required intervals for oil and filter changes. Change oil at least every 12 months even if less than the specified hours have accumulated. Reduce this period for prolonged operation in dusty areas, in cold climates where sludging conditions exist, or

where short flights and long idle periods are encountered, which cause sludging conditions.

Caution

Never operate with less than the minimum engine oil level on dipstick marking.

2.16 Engine induction air filter

The induction air filter keeps dust and dirt from entering the induction system. The value of maintaining the air filter in a good clean condition could never be overstressed as contaminated air is responsible for considerable amounts of wear on the engine. The filter should be removed, inspected and cleaned as necessary at least every 50 hours and more frequently if warranted by use in non-ideal operating conditions. Due to reasons of flight safety the filter should be replaced after using 100 hours of engine operation time or one year, whichever should occur first.

Note

The aircraft is equipped with an oiled K&N Filter Element, which can be cleaned and re-oiled when necessary. Its special design provides extended servicing intervals. For proper cleaning and re-oiling the use of K&N air filter cleaner is recommended and K&N air filter oil is required.

Caution

The filter has to be replaced if damaged, if in doubt, the filter has to be replaced as a precaution to flight safety. Be sure air box is clean before installing a new filter.

2.17 Battery

The installed battery needs no further servicing, except checking cable connections. It is important to check battery voltage when the aircraft is out of service for more than two weeks. Battery voltage has to maintain at least 12.0 volts without engine running and all equipment switched off and master switch in "off" position (regular voltage 12.5 volts). If voltage does indicate 12.2 volts or less it has to be charged. Charging instructions can be found on the battery. If battery voltage is less than 11.8 volts a replacement battery is required.

2.18 Tires

Maintain the tire pressures at the air pressure specified in figure 1-1. When checking tire pressure, examine tires for wear, cuts, bruises and spillage. Remove oil, grease and mud from tires with soap and water.

Note

Recommended tire pressures should be maintained. Especially in cold weather, remember that any drop in temperature of the air inside a tire causes a corresponding drop in air pressure.

Figure 2-1.

1. Airbox (1.)
 2. Air intake to airbox (2.)
 3. Oil radiator (3.)
-

Figure 2-2.

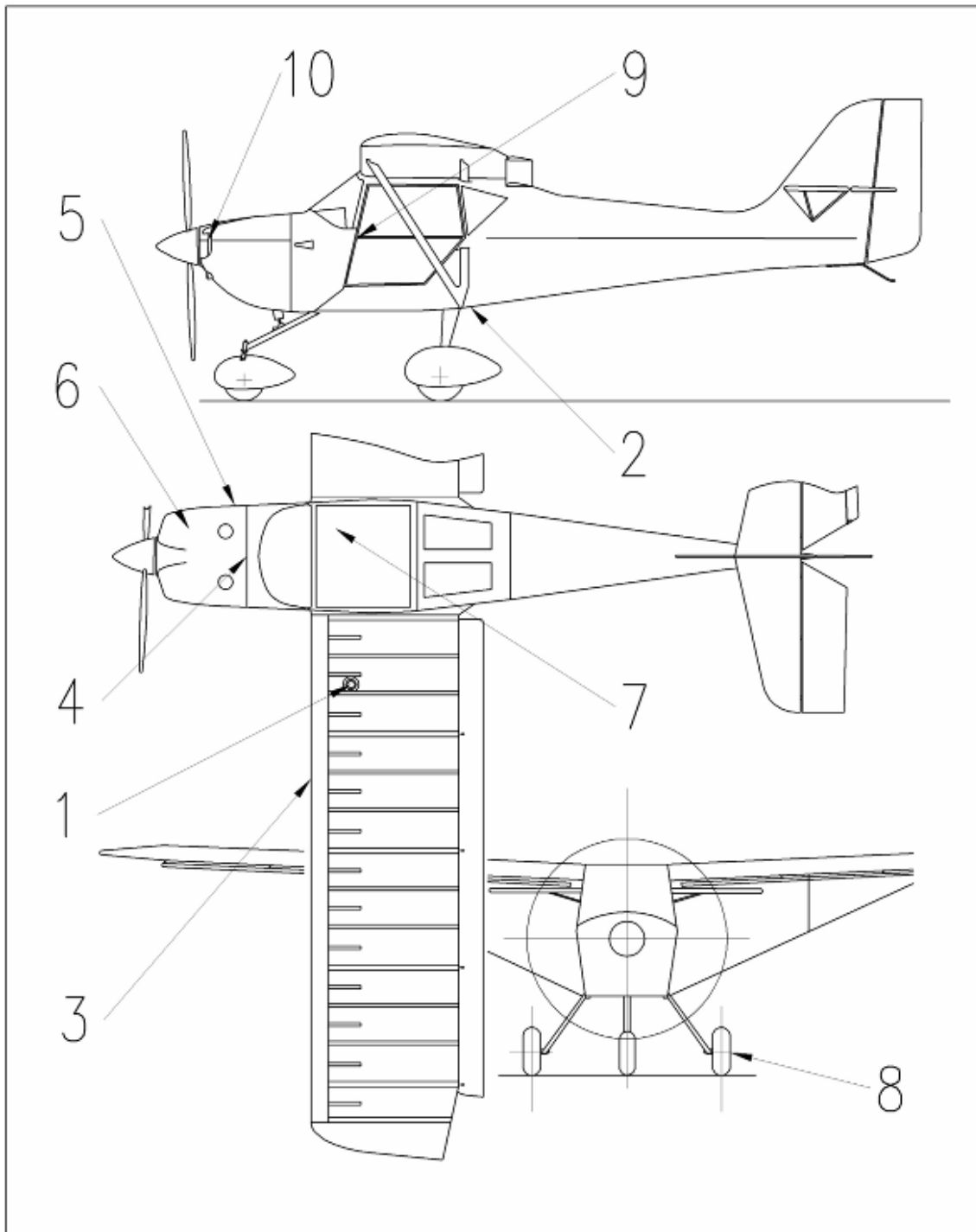

Figure 2-2.

Daily	
1	Fuel tank filler Service after each flight. Keep full to reduce the possibility of condensation in the fuel tank. Refer to paragraph 2.13.
2	Fuel tank sump drain Drain off sufficient amount to test for water or sediment contamination before first flight of the day.
3	Pitot and static ports Check for damage, alignment and blockages before first flight of the day.
4	Induction air filter Inspect and service regularly, give extra consideration when in dusty conditions. Refer to paragraph 2.16 for details.
5	Oil dipstick and oil filler cap Check oil on pre-flight. Add oil if necessary. Check base of cap for water contamination. Refer to paragraph 2.15 for details
10	Engine cooling system Check water level on preflight. Add specified coolant as required. Refer to the POH and latest engine manufactureres manual for details.
First 25 hours	
6	Engine oil system Drain and refill Oil with recommended engine oil grade, replace oil filter.
100 hours	
4	Induction air filter Clean filter per paragraph 2.16, replace as required.
7	Battery Check for correct voltage level. Charge or replace if required. Refer to paragraph 2.17 for details.
8	Tires Maintain correct tire inflation as listed in figure 1-1. Also refer to paragraph 2.18 for details.
200 hours	
9	Brake master cylindr Check fluid level and refill as required with DOT 4 automobile hydraulic fluid. Refer to paragraph 2.19 for details.
2	Fuel tank sump drain Drain sufficient amount to check for trances of water or sediment, refer to paragraph 2.14 for details.

2.19 Hydraulic brake system

Check brake master cylinder and refill with correct grade of brake fluid. To refill, DOT 4 automobile brake fluid is required, as specified in the inspection chart, and no aircraft hydraulic fluid should ever be used! Bleed the brake system to remove entrapped air whenever there is a spongy response to the brake lever. Refer to paragraph 5.40 for filling and bleeding the brake system.

2.20 Cleaning

Keeping the aircraft clean is important. Besides maintaining the appearance of the aircraft, cleaning makes inspection and maintenance easier and in some occasions may highlight defects missed in a pre-flight inspection.

2.21 Windshield and windows

Windows should be cleaned carefully with plenty of fresh water and a mild detergent, using the palm of the hand to feel and dislodge any caked dirt or mud. A sponge, soft cloth, or chamois may be used, but only as a means of carrying water to the acrylic. Rinse thoroughly, then dry with a clean moist chamois. Do not rub the acrylic with a dry cloth as this builds up an electrostatic charge which attracts dust. Oil and grease may be removed by rubbing lightly with a soft cloth moistened with a suitable solvent. Always use vertical strokes to prevent glare scratches.

Caution

When cleaning the windshields, do NOT use gasoline, alcohol, benzene, acetone, carbon tetrachloride, fire extinguisher fluid, de-icer fluid, laquer thinner, or glass window cleaning spray. These solvents will soften and craze the acrylic windows. After washing, the acrylic windshield and windows should be cleaned with an aircraft windshield cleaner. Apply the cleaner with soft cloths and rub with moderate pressure. Allow the cleaner to dry, then wipe it off with soft flannel cloths. A thin, even coat of special acrylic window polish will fill-in minor scratches and help prevent any further scratching. Do not use a canvas cover on the windshield or windows unless freezing rain or sleet is anticipated since the cover may scratch the acrylic surface.

Caution

Do not use any laquer polish like carnauba wax on the acrylic windows.

2.22 Plastic trim

Cleaning the instrument panels plastic trim and control levers need only be wiped with a damp cloth. Oil and grease on the control sticks and control levers can be removed with a cloth moistened with a suitable solvent. Volatile solvents, such as mentioned in paragraph 2.21. should never be used since they soften and craze the plastic.

2.23 Painted surfaces

The painted exterior surfaces of the aircraft, under normal conditions, require a minimum of polishing and buffing. Approximately two weeks are required for acrylic paint to cure completely; in most cases, the curing period will have been completed prior to delivery of the aircraft. In the event that polishing or buffing is required within the curing period, it is recommended that the work is done by an experienced painter. Generally, the painted surfaces can be kept bright by washing with water and mild soap, followed by a rinsing ther surfaces with water and drying with cloths or chamois. Harsh or abrasive soaps or detergents which could cause scratches should never be used. After the curing period, the aircraft may be waxed with a good automotive wax. A heavier coating of wax on the leading edge of the wing and tail and on the engine cowling will help reduce the abrasion encountered in these areas.

2.24 Aluminum surfaces

Some aluminum surfaces will require a minimum of care due to their anodized coating, but should never be neglected. Many good aluminum cleaners are available from commercial suppliers of aircraft products. Household type detergent soap powders are effective cleaners, but should only be used very cautiously since some of them are strongly alkaline and will cause damage.

2.25 Engine and engine compartment

The engine should be kept clean since dirty cooling fins may cause engine overheating. Also, cleaning is essential to minimize any danger of fire and provide for easier inspection of components. The entire engine cowling may be removed to facilitate engine and interior cowl cleaning. Wash down the engine and components with a suitable solvent, then dry thoroughly with compressed air if available.

Caution

Particular care should be given to electrical equipment before cleaning. Solvent should not be allowed to enter magnetos, starter, alternator, voltage regulator and the like. Hence, these components should be protected before saturating the engine with solvent. Any fuel, oil and air openings should be covered before washing the engine with solvent. Caustic cleaning solutions should not be used. After cleaning engine re-lubricate all control arms and moving parts.

2.26 Upholstery and interior

Keeping the upholstery and interior clean prolongs upholstery fabric and interior trim life. To clean the interior, proceed as follows:

- a. Brush or vacuum clean the upholstery and carpet to remove dust and dirt.
- b. Clean upholstery with a sponge moistened with fresh water
- c. Wipe plastic trim with a damp cloth.
- d. Oil spots and stains may be cleaned using household spot removers, sparingly. Before using any solvent, read the instructions on the container and test it on an obscure place in the fabric to be cleaned. Never saturate the fabric with volatile solvent; it may damage the padding and backing material. Scrape sticky material from the fabric with a dull knife, then spot clean the area.

2.27 Propeller

Wash hub and blades with a soft cloth and suitable cleaning solvent, then dry thoroughly with compressed air.

Caution

Do not use gasoline, alcohol, benzene, acetone, or laquer thinner. These solvents will soften and damage the laquer finish.

2.28 Wheels

The wheels should be washed periodically and examined for corrosion, cracks and dents in the wheel halves or hubs. If defects are found, remove and repair in accordance with Section 5. Discard cracked wheel hubs and install new parts.

2.29 Lubrication

The EuroFox has been designed to have as few lubrication points as possible. For areas that do require lubrication, regular grease should be used. The following list details the areas that will require frequent lubrication.

- a. Wing main bolts
- b. Wing folding mechanism hinge
- c. Wing flap push-pull rods connection and hinges
- d. Stabilizer mounting bolts
- e. All control surface hinges in general
- f. Undecarriage bearing and movable holder

Caution

Do not lubricate pulleys and bushings of control surface cables and rods. When changing wheels it is recommended to lubricate wheel axles before reassembling to prevent them from corrosion and keep wheel changing easier.

2.30 Inspection

I. Inspection requirements

As required by Federal Aviation Regulations, all civil aircraft of U.S. registry must undergo a complete inspection (annual) each twelve calendar months. In addition to the required Annual Inspection, aircraft operated commercially (for hire) must also have a complete aircraft inspection every 100 hours of operation.

II. Inspection charts

The following charts show the recommended intervals at which items are to be inspected.

As shown in the charts, there are items to be checked after the first 20 hours of service, each 100 hours and 200 hours.

To conduct these inspections it is mandatory to use the factory inspection form (**AEROPRO Checklist Service/Maintenance**) latest issue.

- a. When conducting the after sales 20 hour inspection, all items marked as 20 hour service would be inspected, serviced or otherwise accomplished as necessary to insure continued airworthiness.
- b. At each 100 hours, the 20 hour items would be accomplished in addition to the items marked as 100 hour service as necessary to insure continued airworthiness.
- c. At each 200 hours, the 100 hour items would be accomplished in addition to the items marked as 200 hour service as necessary to insure continued airworthiness.
- d. The numbers appearing in the "special inspection item" (S.i.i.) column refer to data listed at the end of the inspection charts. These items should be checked at each inspection interval to insure that applicable servicing and inspection requirements are accomplished at the specified intervals.
- e. A complete aircraft inspection includes all 20, 100 and 200 hour items plus those special inspection items which are due at the time of the inspection.

III. Inspection guidelines

- a. Moveable parts for: lubrication, servicing, security of attachment, binding, excessive wear, safety, proper operation, proper adjustment, correct travel, cracked fittings, security of hinges, defective bearings, cleanliness, corrosion, deformation, sealing and tension.
- b. Fluid lines and hoses for: leaks, cracks, dents, kinks, chafing, proper radius, security, corrosion, deterioration, obstruction and foreign matter.
- c. Metal parts for: security of attachment, cracks, metal distortion, broken spotwelds, corrosion, condition of paint and any other apparent damage.
- d. Composite parts for: cracks, dents and de-lamination.
- e. Wiring for: security, chafing, burning, defective insulation, loose or broken terminals, heat deterioration and corroded terminals.
- f. Bolts in critical areas for: correct torque in accordance with torque values given in the chart in Section 1, when installed or when visual inspection indicates the need for a torque check.

Caution

Torque values listed in Section 1 are derived from oil-free cadmium-plated threads and are recommended for all installation procedures contained in this manual except where other values are stated. They are not to be used for checking tightness of installed parts during service.

- g. Filters and fluids for: cleanliness, contamination and/or replacement at specified intervals.
- h. Aircraft file: Miscellaneous data, information and licences are a part of the aircraft file. Check that the following documents are up-to-date and in accordance with current Federal Aviation Regulations. Most of the items listed are required by the United States Federal Aviation Regulations.

To be displayed in the aircraft at all times:

1. Aircraft Airworthiness Certificate.
2. Aircraft Registration Certificate.

To be carried in the aircraft at all times:

1. Weight and Balance and associated papers (latest copy of the Repair and Alteration Form if applicable).
2. Aircraft Equipment List.

To be available upon request:

1. Aircraft Log Book

i. Engine run-up

Before beginning the step-by-step inspection, the pilot should start, run-up and shut down the engine in accordance with instructions in the Pilot Operating Handbook. During run-up, observe the following, making note of any discrepancies or abnormalities. It is strongly recommended that the “static-test-report form” included in the **AEROPRO Checklist – Service/maintenance** form is used during any run up inspection.

1. Engine temperatures and pressures.
2. Static rpm.
3. Magneto drop.
4. Engine response to changes in power.
5. Any unusual engine noises.
6. Fuel shut-off valve function.
7. Idling speed.
8. Charge control and battery voltage.

After the inspection has been completed, an engine run-up should again be performed to determine that any discrepancies or abnormalities have been corrected.

IMPORTANT

**Read all inspection requirements paragraphs
prior to using these charts.**

**These charts may only be used accompanied by the special factory
inspection**

form: AEROPRO Checklist- Service/Maintenance

Service/hours				Propeller
S.i.i.	50	100	200	
	✓	✓	✓	Spinner
	✓	✓	✓	Spinner bulkhead
	✓	✓	✓	Blades
	✓	✓	✓	Bolts and nuts
	✓	✓	✓	Spacer

Service/hours				Engine compartment
S.i.i.	50	100	200	
	✓	✓	✓	Check for evidence of oil and fuel leaks, then clean entire engine and compartment if needed, prior to inspection.
	✓	✓	✓	Engine oil, filler cap, dipstick, drain plug, filter element
	✓	✓	✓	Oil cooler
1	✓	✓	✓	Induction air filter
	✓	✓	✓	Induction air box, doors and controls
	✓	✓	✓	Cold and hot air hoses
	✓	✓	✓	Cylinders, rocker box covers and push rod housings
	✓	✓	✓	Crankcase, oil sump, accessory section and crankshaft seal
	✓	✓	✓	Gear drive case and propeller shaft seal
2	✓	✓	✓	Hoses, metal lines and fittings
3	✓	✓	✓	Intake and exhaust system
	✓	✓	✓	Ignition harness
	✓	✓	✓	Spark plugs
	✓	✓	✓	Compression check
	✓	✓	✓	Electrical wiring
4	✓	✓	✓	Engine controls and linkage
	✓	✓	✓	Engine shock mounts, mount structure and ground straps
	✓	✓	✓	Cabin heat doors and controls
	✓	✓	✓	Starter, solenoid and electrical connections
	✓	✓	✓	Voltage regulator mounting and electrical leads
	✓	✓	✓	Carburetors
	✓	✓	✓	Firewall
	✓	✓	✓	Engine Cowling

Service/hours	Fuel system
---------------	-------------

S.i.i.	50	100	200	
		✓	✓	Fuel drain valve
		✓	✓	Fuel tank vent, cap and placards
		✓	✓	Fuel tank sump drains
5		✓	✓	Drain fuel and check outlet screen
		✓	✓	Fuel shut-off valve and placards

Service/hours				Landing gear
S.i.i.	50	100	200	
		✓	✓	Main gear wheels and fairings
		✓	✓	Nose gear wheel and fairing
6		✓	✓	Wheel bearings
		✓	✓	Tires
		✓	✓	Brake fluid, lines and hoses, linings, discs, brake assembly, master cylinder and Parking brake
		✓	✓	Main gear struts

Service/hours				Airframe
S.i.i.	50	100	200	
		✓	✓	Aircraft exterior
		✓	✓	Aircraft frame structure
		✓	✓	Windows, windshield, doors and seals
		✓	✓	Seat belts and shoulder harnesses
		✓	✓	Seat structure, mounting and upholstery
		✓	✓	Control bearings, pulleys, cables and rod connections
		✓	✓	Instruments and markings
5		✓	✓	Magnetic compass compensation
		✓	✓	Instruments and wiring
		✓	✓	Instrument panel, ground straps, covers, decals
		✓	✓	Heating and ventilation system
		✓	✓	Lights, switches, circuit breakers
		✓	✓	Exterior lights
		✓	✓	Pitot and static system
		✓	✓	Radios and avionics
		✓	✓	Antennas and cables
7		✓	✓	Battery

Service/hours				Control systems
S.i.i.	50	100	200	
		✓	✓	In addition to the items listed below, always check for correct direction of movement, correct travel and correct cable tension.
		✓	✓	Trim control holder, rope and brake of the movement of lever
		✓	✓	Travel stops
		✓	✓	Flap control holder, brake of the movement of lever
		✓	✓	Flap and ailerons mixer and rods
		✓	✓	Decals and labeling

		✓	✓	Elevator and trim tab hinges and control rods
8		✓	✓	Elevator trim tab
		✓	✓	Rudder pedal assembly and linkage
		✓	✓	Skins of control surfaces

Special inspection items (S.i.i. as outlined in chart above)

1. Check filters per paragraph 2.16. Replace if required.
2. Replace hoses at engine overhaul or after 5 years, whichever comes first.
3. General inspection every 50 hours, Refer to Section 11 for 100 hour inspection.
4. Each 50 hours for general condition and freedom of movement. These controls are not repairable. Replace as required at each engine overhaul.
5. Each 1000 hours or to coincide with engine overhaul.
6. First 100 hours and each 200 hours thereafter. More often if operated under prevailing wet or dusty conditions.
7. Check battery voltage per paragraph 2.17 each 100 hours.
8. Check linkage for cracks and free play, lubricate with regular grease every 50 hours.

Note	A high-time inspection is merely a 100-hour inspection with the addition of an engine overhaul. Rotax recommends engine overhaul at 2000 hours for the 912 Series engine. At the time of overhaul, engine accessories should be overhauled.
-------------	---

Section 3

Structures - Fuselage

Table of contents	Page
3.1 Fuselage	3-1
3.2 Windshield and Windows.....	3-2
3.3 Description.....	3-2
3.4 Cleaning.....	3-2
3.5 Waxing.....	3-2
3.6 Repairs.....	3-2
3.7 Scratches.....	3-2
3.8 Cracks.....	3-3
3.9 Replacement.....	3-4
3.10 Removal.....	3-4
3.11 Installation.....	3-4
3.12 Cabin Doors	3-5
3.13 Removal and installation.....	3-5
3.14 Cabin door latches.....	3-6
3.15 Lock	3-6
3.16 Removal and installation.....	3-6
3.17 Seats	3-7
3.18 Description.....	3-7
3.19 Removal.....	3-7
3.20 Repair.....	3-7
3.21 Upholstery.....	3-7
3.22 Baggage compartment	3-7
3.23 Safety Provisions	3-8
3.24 Ballistic Recovery System.....	3-8
3.25 Description.....	3-8
3.26 Installation.....	3-8
3.27 Safety belts.....	3-9
3.28 Baggage for charts.....	3-9

3.1 Fuselage

The main supporting structure of the fuselage is a lattice-work welded of steel tubes. The cockpit is located in the middle section of the fuselage and is accessible through large, vertically opening doors hinged on to the top of the door frames. The aircraft is a side by side two seat configuration, the seats being constructed of a fiberglass frame with fabric upholstery. Pilots are fastened with four-point safety belts anchored to the fuselage framework. The engine is located in front of the cockpit, separated from the cockpit by the firewall. The nose of the fuselage consists of a two piece fiberglass engine cowling.

The rear fuselage section consists of the attachment points for the tail fin and the horizontal stabilizer. On the upper fuselage behind the wing is located a detachable cover allowing the wings to fold backward. The whole fuselage surface except for the forward section is fabric-covered.

3.2 Windshield and Windows

3.3 Description

The cockpit skylights and doors are of polycarbonate material. The windshield is of acrylic (Plexiglass) material and is glued and riveting to the fuselage supported by aluminium plates to achieve the best possible aerodynamics and eliminate wind noise.

3.4 Cleaning

Refer to Section 2.

3.5 Waxing

Waxing will remove minor scratches in clear plastic and help protect the surface from further abrasion. Use a good grade of commercial wax applied in a thin, even coat. Bring wax to a high polish by rubbing lightly with a clean, dry flannel cloth.

3.6 Repairs of Windshield

Damaged window panels and windshield may be removed and replaced if damage is extensive. However, certain repairs as prescribed in the following paragraphs can be made successfully on the acrylic front windshield without removing the damaged screen from aircraft. Three types of temporary repairs for cracked plastic are possible. No repairs of any kind are recommended on highly-stressed or compound curves where repair would be likely to affect pilot's field of vision. Curved areas are more difficult to repair than flat areas and any repaired area is both structurally and optically inferior to the original surface.

3.7 Scratches

Scratches on clear acrylic (but not polycarbonate) surfaces can be removed by hand-sanding operations followed by buffing and polishing, if steps below are followed carefully.

- a. Before attempting any scratch removal it is necessary to confirm the process and materials and tools being used with the EuroFox

manufacturer, distributor, a qualified aviation technician, or a distributor of the acrylic material.

- b. Wrap a piece of extremely fine sandpaper or abrasive cloth around a rubber pad or block of wood. Rub surface around scratch with a circular motion, keeping abrasive constantly wet with clean water to prevent scratching surface further. Use minimum pressure and cover an area large enough to prevent formation optical distortions.

Caution

Do not use a coarse grade of abrasive. No 400 is of maximum coarseness.

- c. Continue sanding operation, using progressively finer grade abrasives until scratches disappear. Do not skip one grade of abrasive!
- d. When scratches have been removed, wash area thoroughly with clean water to remove all gritty particles. The entire sanded area will be clouded with minute scratches which must be removed to restore transparency.
- e. Apply first tallow or buffing compound to a motor-driven buffing wheel. Hold wheel against plastic surface, moving it constantly over damaged area until cloudy appearance disappears. A 2000-feet-per-minute surface speed is recommended to prevent overheating and distortion. (Example: 750 rpm polishing machine with a 10 inch buffing bonnet)

Note

Polishing can be accomplished by hand but will require a considerably longer period of time to attain the same result as produced by a buffing wheel.

- f. When buffing is finished, wash area thoroughly and dry with a soft flannel cloth. Allow surface to cool and inspect area to determine if full transparency has been restored . Apply a thin coat of hard wax and polish surface lightly with a clean flannel cloth.

Note

Rubbing plastic surfaces with a dry cloth will build up an electrostatic charge which attracts dirt particles and may eventually cause scratching of surface, After wax has hardened, dissipate this charge by rubbing surface with a slightly damp chamois. This will also remove dust particles which have collected while wax is hardening.

- g. Minute hairline scratches can often be removed by rubbing with commercial automobile body cleaner or fine-grade rubbing compound. Apply with a soft, clean, dry cloth or imitation chamois.

3.8 Cracks

- a. When a crack appears, drill a hole at end of crack to prevent further spreading. The hole should be approximately 1/8 inch in diameter, depending on length of crack and thickness of material.
- b. Temporary repairs to flat surfaces can be accomplished by placing a thin strip of wood over each side of surface and inserting small bolts through wood and plastic. A cushion of sheet rubber or aircraft fabric should be placed between wood and plastic on both sides.
- c. A temporary repair can be made on a curved surface by placing fabric patches over affected areas. Secure patches with aircraft dope or laquer thinner.

Note	These type of repairs is used as a temporary measure ONLY , and as soon as facilities are available, panel should be replaced.
-------------	---

3.9 Replacement

3.10 Removal

- 3.10.1 Required Tools: Jig saw, crowbar, power drill, abrasive paper
- 3.10.2 Parts required: None
- 3.10.3 Level of Maintenance: **Heavy**
- 3.10.4 Certification required: **A&P Mechanic**

- a. Cut out the old windshield window using a jig saw without causing damage to the instrument board panel, windshield plate and fuselage, remove old rivets on the upper and side plates. Remove the instrument board panel.
- b. Remove the remaining border of the windshield by the use of an appropriate prybar and sand off old glue to get a smooth joining surface at the fuselage.

3.11 Installation

- 3.11.1 Required Tools: Jig saw, epoxy resin and hardener, abrasive paper (30 & 180 grain size), tape, Rivets 3,2x8mm and 4,2x8mm, lacquer and appropriate utilities.
- 3.11.2 Parts required: windshield as required
- 3.11.3 Level of Maintenance: **Heavy**
- 3.11.4 Certification required: **A&P Mechanic**
- a. Clip and fit the new windshield to the required size.

Caution

Use great care when cutting the windshield with a jig saw, the temperature of the window must be 65° F at least. Lower temperatures could more easily cause the material to crack or break when sawing.

- b. When the new windscreen is correctly positioned, fit the upper plate and fix it to the fuselage using three 2x8mm rivets, using silicone adhesive between the aluminium plate and window.
- c. Then you rivet the aluminium plates and the M4x4 holding screws.
- d. You glue transitionally the pplate between the leading edge and window, and let the epoxy cure again for 24 hours at 65° F at least. Apply polyester putty, primer and lacquer to finish your work.
- e. You glue the upper plate of board panel into place and let the epoxy cure again for 24 hours at 65° F at least.
- f. Reinstall the complete instrument board panel.

3.12 Cabin Doors

The cockpit is accessed via a clear, polycarbonate door on either side of the aircraft. The doors are fitted to the airplane by hinges along its upper edge. The doors are supported when in the open position by a gas pressure spring. Both doors are lockable and have a glazed finish.

Caution

The doors windows are polycarbonate material which is not protected of fuel

3.13 Removal and Installation

3.13.1	Required Tools:	8 & 10mm wench
3.13.2	Parts required:	None
3.13.3	Level of Maintenance:	Light
3.13.4	Certification required:	Owner

To remove cabin doors (refer to figure 3-1) unlock and open the doors, detach the support gas struts (3) from the door bracket (4). Withdraw safety pins from both rear hinges on the upper edge of the doors (2). Installation is carried out in reverse order.

Figure 3-1



1. Front Hinges
 2. Rear Hinges Screw M5x15
 3. Gas Struts
 4. Upper holder of Gas Struts on the door frame
 5. Down holder of Gas Strut on the Fuselage
 6. Rear door handle of the door
-

3.15 Lock

3.16 Removal and Installation

- 3.16.1 Required Tools: 2.5 mm allen wrench, needle-nosed pliers, screwdriver.
- 3.16.2 Parts required: Door handle set, Loctite 243 (medium strength).
- 3.16.3 Level of Maintenance: **Light**
- 3.16.4 Certification required: **Owner**

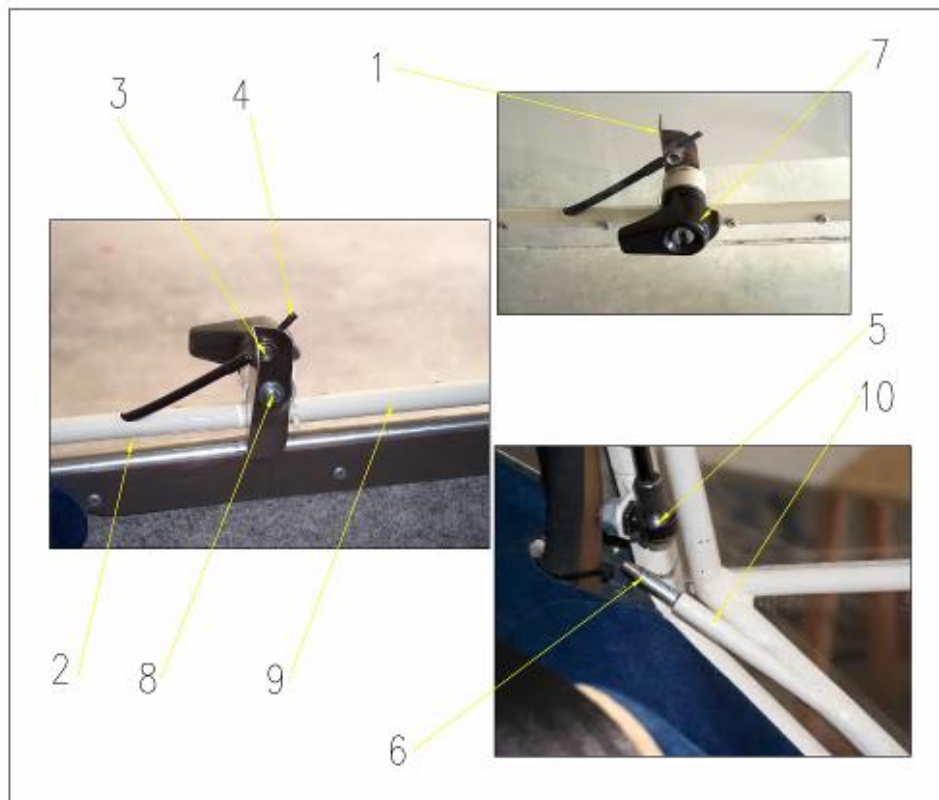
Figure 3-2



1. Inner Pawl
 2. Door frame
 3. Bowden
 4. Control rope for Pawl
 5. Fuselage holder of Gas Strut
 6. Retral Pawl
 7. Main Lock of door
 8. Screw for ropeholding
 9. Main screw of Lock
 10. Tube for Retral Pawl
-

For removal use the following steps. For installation reverse the sequence:

- a. Remove Screw (3) and take away Retral Pawl (6)
- b. Remove Screw (8) and take away Inert Pawl and from the oposite side take away the main door lock.
- c. For instalation use optimal lubricating Vaseline and use LOCTITE 243 (medium strength) to secure the screw.

3.17 Seats

3.18 Description

The pilot and co-pilot seats are manufactured as a one-piece fiberglass component, attached to the fuselage at nine points. The seats are not adjustable.

3.19 Removal of Seats

3.19.1 Required Tools:	for need
3.19.2 Parts required:	none
3.19.3 Level of Maintenance:	Light
3.19.4 Certification required:	Owner

Undo the seat belts. Carefully remove the fabric cushions from the composite seat frame. Unscrew and remove all 9 screw fittings from the seat frame and remove seat.

3.20 Repair

If cracks are detected in any of the glass fiber seat shells, they may be repaired using L285 Epoxy Resin or similar (R&G L20), reinforced with suitable glass fiber fabrics. Follow the instructions on the container for a successful repair.

3.21 Upholstery

Due to the wide selection of fabrics, styles and colors, it is impossible to depict each particular type of upholstery. The following paragraphs describes general procedures which will serve as a guide in removal and replacement of upholstery. Major work, if possible, should be done by an experienced mechanic.

Materials and tools will vary with the particular job. Scissors for trimming upholstery to size and a dull-bladed putty knife are the only tools required for most trim work. Use industrial rubber cement to hold mats and fabric edges in place.

3.22 Baggage Compartment

The baggage compartment of 700 x 530 x 570 mm size is located behind the cockpit seats. It is accessible from between the seats and can hold baggage up to 65 lb. It is not possible to remove the baggage compartment as it is installed before being covered by the fabric.

3.23 Safety provisions

3.24 Ballistic Recovery System

3.25 Description

The Eurofox may be installed with a BRS parachute rescue system.

3.26 Installation

- 3.26.1 Required tools: Power drill, 6.5 mm drill, phillips head screwdriver,
edge cutter, 4 & 5 mm allen wrench, 8 mm wrench.
- 3.26.2 Parts required: Bracket for rocket motor incl. screw kit, 50" of 6 mm nylon rope, Loctite 243/242 (medium strength), cable ties, socket screw (M6 x 25 mm) + washer and retainer.
- 3.26.3 Level of maintenance: **Heavy**
- 3.26.4 Certification required: **A&P Mechanic or Repairman Maintenance**

Figure 3-3

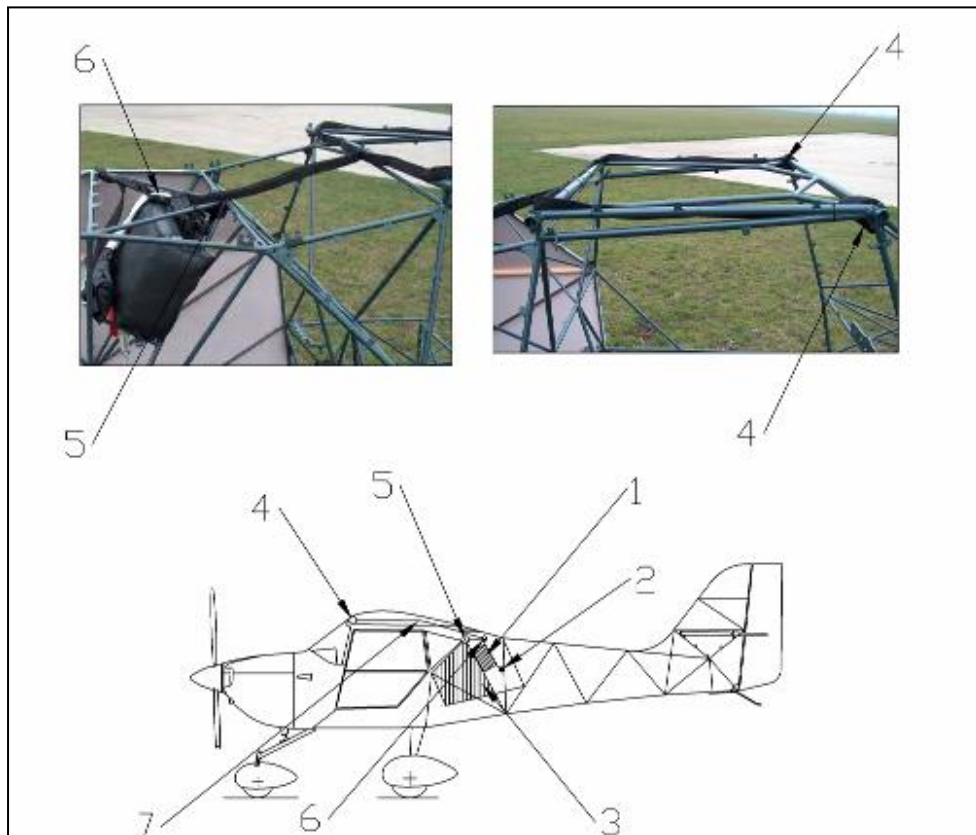

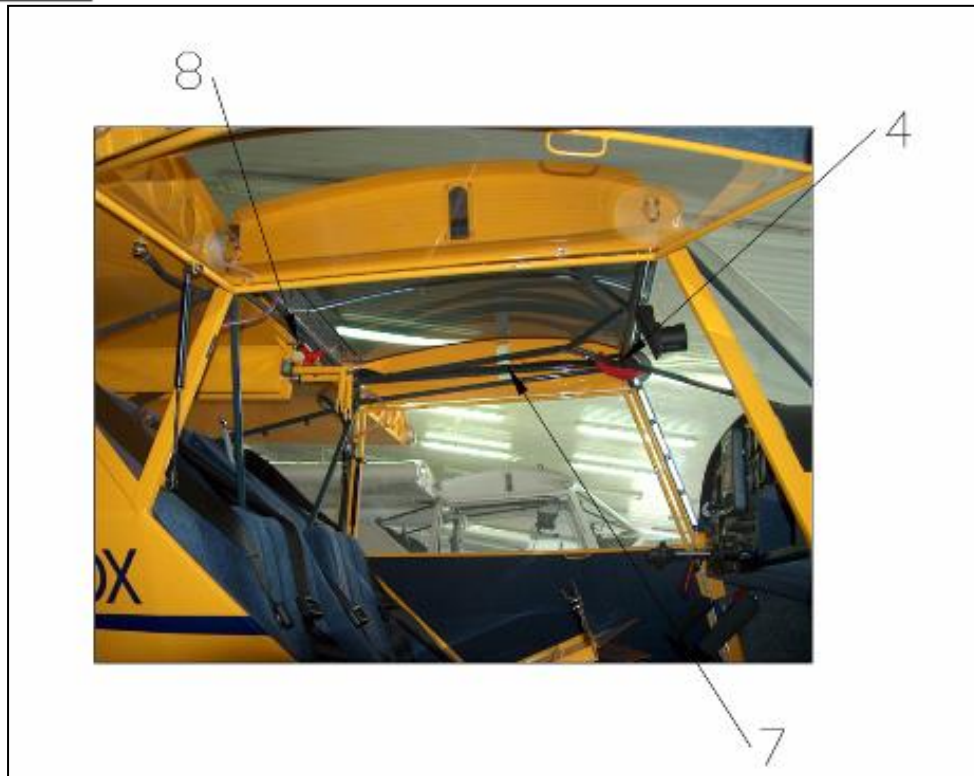

1. Parachute rescue system
2. Rocket motor
3. Baggage compartment
4. Front two points for installation front belts
5. Rear one point for installation rear belt
6. Clips for connection of belts
7. Belts
8. Holder for activation rocket motor

If the aircraft is to be equipped with the BRS system, follow the instructions in the rescue system installation manual. A special mounting kit, containing the bracket for the rocket motor and some miscellaneous parts can be obtained from Aeropro or the local distributor. Figure 3-3. illustrates the installation of the rescue system in the aircraft.

Warning

When working on the ballistic parachute system, ensure that the securing pin is installed to the system and always take great care. An unintended launch of the rocket motor could cause serious injury or death.

3.27 Safety belts

The seats are of a side-by-side arrangement, situated in the fuselage centre section. They consist of an upholstered fiberglass skeleton. Each pilot's

seat is equipped with four-point safety belts anchored in the fuselage lattice-work.

3.28 Baggage for charts

A small storage area is located on the lower right hand side of the board panel. This is ideal for the storage of such items as charts and other navigational equipment up to a maximum weight of 5 lb.

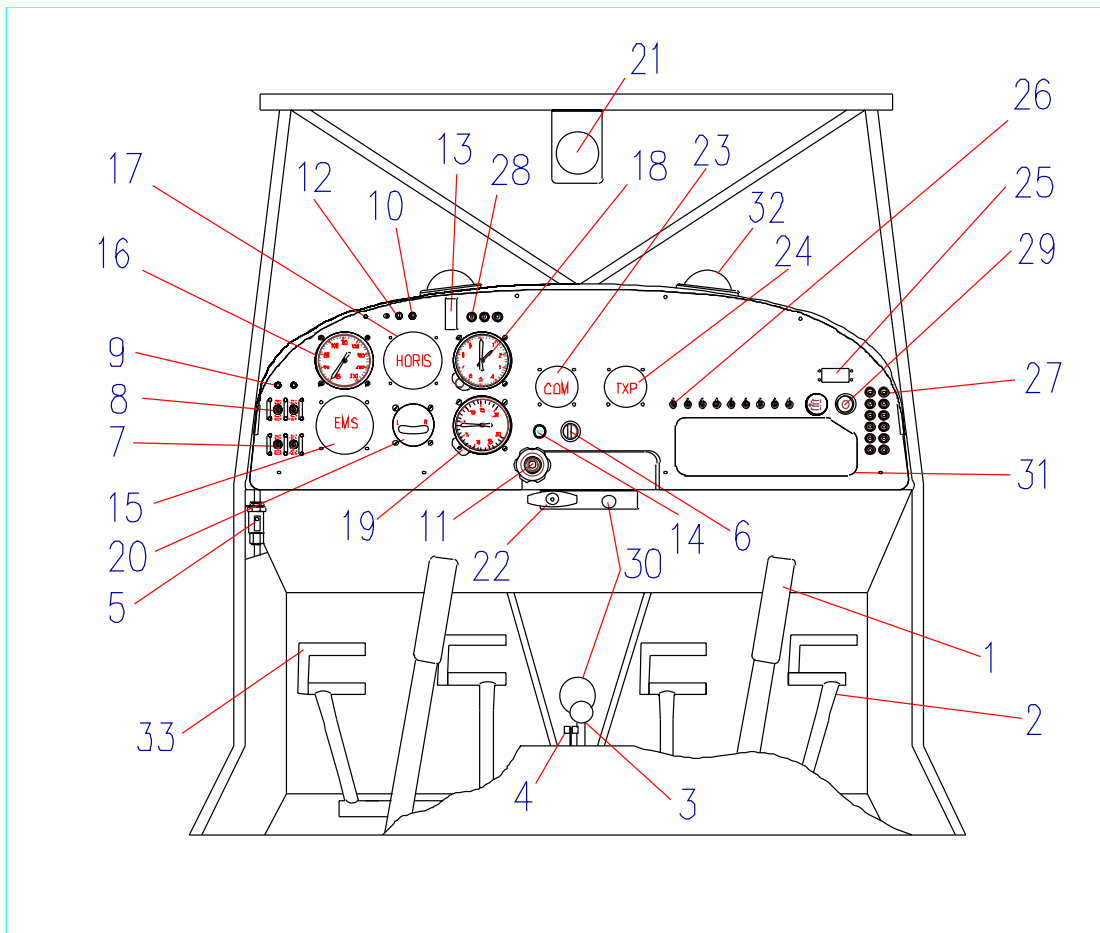

Figure 1 – Cockpit overview

LAYOUT OF CONTROLS AND INSTRUMENTS

(see following pages for details)

1. Control stick	16. Air speed indicator	e) Transponder
2. Rudder pedals	17. HORIS	f) GPS
3. Wing flaps	18. Altimeter	g) Free
4. Trim elevator	19. VSI	h) Free
5. Fuel valve	20. Slip indicator	i) USB
6. Master switch	21. Magnetic Compass	27. Service C/Bs
7. Fuel pump switches	22. Tow hook release	28. Engine C/Bs
8. ECU switches	23. COM Radio	29. USB port + 12V socket
9. ECU lights	24. Transponder	30. Cabin heating
10. Momentary switch light	25. ELT	31. Glove box
11. Throttle lever	26. Section Switches	32. Ventilation
12. Fuel reserve light	a) Landing lights	33. Pedal brakes
13. Backup battery switches	b) Position lights	
14. Startup button	c) Strobe lights	
15. Engine Mon. system	d) Radio	

LAYOUT OF CIRCUIT BREAKERS

Landing lights	10A	Free	5A
Position lights	2A	Free	5A
Strobe lights	3A	USB	3A
Radio COM	5A	Kanardia	2A
Transponder	3A	EMSIS	2A
GPS	2A	12V Socket	5A

Key Switch	30A	Backup battery	30A	Fuse box	30A
------------	-----	----------------	-----	----------	-----

II. List of installed instruments and other equipment:

Instrument	Type	Serial No.
Air Kanardia	Horis PFD (Master)	25254
	Airspeed Indicator (Slave)	25570
	Altimeter 80 (Slave)	24456
	Vertical Speed Indicator (Slave)	30306
	EMSIS	19865
	MiniDaqu	20093
TQ	KRT2-S-TQ	50001299T
	KTX2-S.V2	20001603T
ACK	E-04	45005
FALCON	MCPN2L	2202114

Section 4 Structures – Wings and Empennage

Table of contents	Page
4.1 Wings	4-0
4.2 Description.....	4-0
4.3 Retract wings for transport	4-2
4.4 Removal.....	4-2
4.5 Repair.....	4-5
4.6 Installation.....	4-5
4.7 Installing strut to fuselage.....	4-6
4.8 Installing wing to fuselage.....	4-6
4.9 Wing Struts	4-6
4.10 Description.....	4-6
4.11 Removal and installation.....	4-6
4.12 Tail Unit	4-7
4.13 Description.....	4-7
4.14 Removal and installation.....	4-7

4.1 Wings

4.2 Description

The rectangular-plan wing is of a steel frame structure. It is composed of two duralumin carrying tubes and a system of duralumin ribs and diagonal stiffeners. The duralumin rib system comprises of 14 full ribs and 13 false ribs, stiffening the skin in the leading-edge area of assembly. The horizontal plane section of the wing is strengthened with a system of steel diagonal tubular stiffeners. There is a 40 liter fuel tank built in the wing root section which is welded of aluminium alloy metal sheets. Correct shape of the wing leading edge is guaranteed due to a fiberglass die-formed shell glued on the leading edge tube. The trailing edge is formed of a duralumin shaped piece. The wing is fabric-covered.

Below the wing trailing edge are the flaperons incorporating both function of ailerons and wing flaps; they are attached to the rib ends by means of five hinges. The flaperon structure consists of a duralumin load-carrying tube swinging in the hinges and a fiberglass sandwich part, itself an inversely moulded airfoil.

The wings are attached to the fuselage by suspension points of load-carrying tubes in the upper section of the wing and are anchored by „V“ struts to the bottom fuselage edge. The system of attachment uses an axle common for the wing rear suspension and the strut makes it possible to swing the wings simply backward lengthwise the fuselage, thus reducing demands on storage space and road transport.

Figure 4-1



4.3 Retract wings for transport (according to figure 4-1)

4.3.1 Required Tools:	Screwdriver, 8,9,12 mm wrench
4.3.2 Parts required:	None
4.3.3 Level of Maintenance:	Line
4.3.4 Certification required:	Owner

To transport the aircraft, it is necessary to fold the wings to the transport position, i.e. to disconnect the wing front suspensions, to fold wings and fix them to the fuselage in transport position secured with connecting rods (pos. 7).

- for short distances the aircraft can be towed on its own landing gear behind a vehicle by means of a simple tow bar attached to the rear fuselage suspension section.

- For longer distances it is recommended to transport the aircraft on a two-wheel trailer, either open or covered.

To prepare the aircraft for transport:

- a. Unlock and remove the rear cockpit cover, put it aside on the seat (pos.1,2).
- b. Shut the wing tank fuel cocks.
- c. Discouple the flaperon tie rods on both wings (pos.3).
- d. Unlock the front clamping bolt connecting the wing to the fuselage.
- e. Move the wing slightly to relieve the front clamping bolt and pull it out. Holding the wing by one hand, fold it carefully backwards while simultaneously checking the movement of the flaperon using the other hand to prevent it from striking on fuselage while being folded into the transport position.
- f. Repeat points d. and e. for the second wing (pos.4).
- g. Fix wings to fuselage by means of connecting rods (pos.7).
- h. Aircraft unfolding is to be carried out in converse sequence beginning from .

4.4 Removal

4.4.1 Required Tools:	10/12/13/14 mm wrench, screwdriver and phillips head screwdriver, needle-nosed pliers.
4.4.2 Parts required:	None
4.4.3 Level of Maintenance:	Heavy
4.4.4 Certification required:	A&P Mechanic

Wing removal is most easily accomplished if three men are available to handle the wing. Otherwise, the wing should be supported with a sling when the fastenings are loosened. When using a sling, great care has to be taken not to damage the wing's surface. If too much pressure is applied to the surface due to unsuitable slings, dents may result. Details of the strut connections are given in figure 4-2. and figure 4-3.

- a. Drain fuel from wing tanks (2)
- b. Disconnect the pitot line at the fuselage (only on left wing).(1)

- c. Disconnect navigation light terminal at wing root.
- d. Disconnect the fuel pipe.(2)
- e. Disconnect the flaperon connection inside the cabin.
- f. Remove the support strut from the wing and main strut. (5)
- g. Support the wing at the outboard end and disconnect the strut at the fuselage.
- h. Disconnect the strut at the wing connection and remove.
- i. Remove and withdraw main wing attachment bolt.
- j. Separate the wing from the fuselage as much as possible, it may be required to lower the wing outboard end for a small amount (1-2 inches).
- k. Rotate the wing 90° so that the leading edge is pointing downwards while moving the outboard end backwards till the wing is aligned with the fuselage tail. Support wing at the root.
- l. Remove wing and lay on padded stand.

Figure 4-3

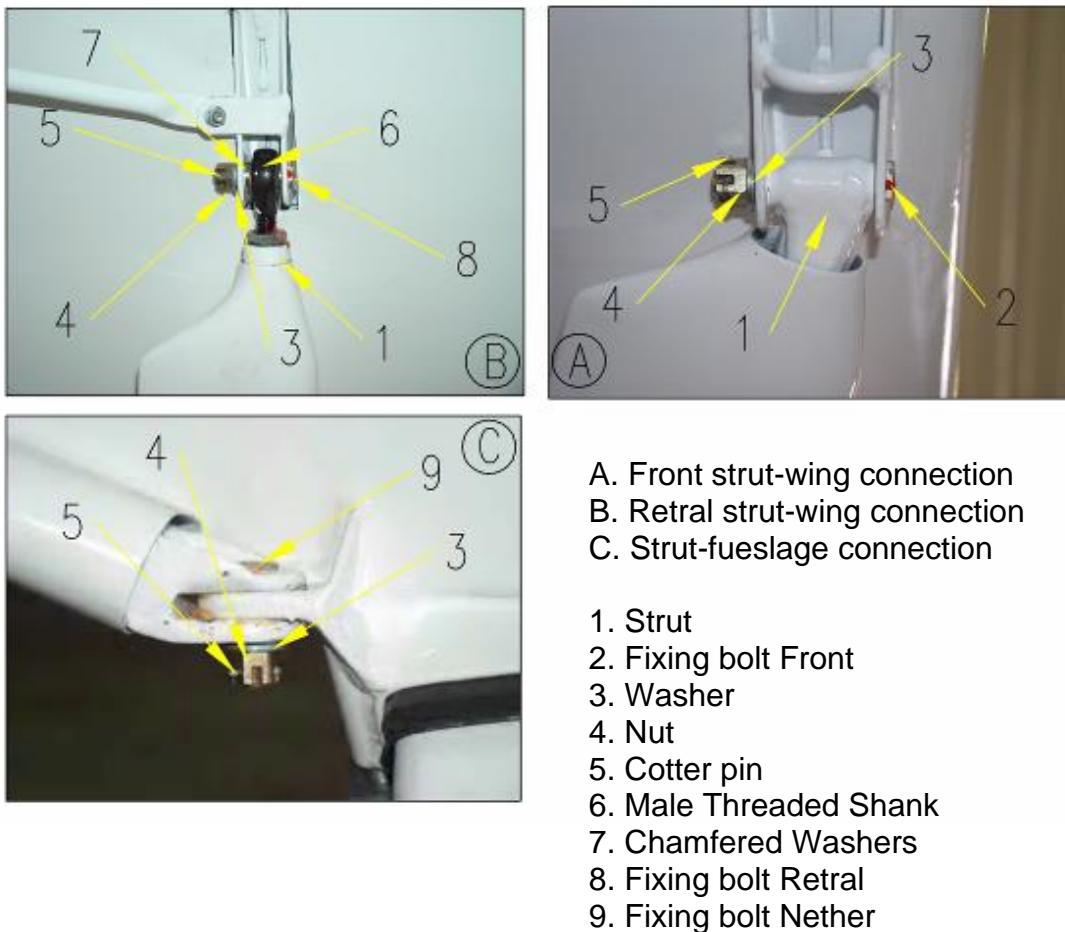

4.5 Repair

A damaged wing may be repaired in accordance with instructions outlined in Section 18. If main spar is damaged or alignment of the wing panel is of

concern, we recommend to replace the whole wing or return it for repair to the factory. Damaged fabric cover may be repaired following the instructions given by the fabric manufacturer (Polyfiber USA).

4.6 Installation

- | | |
|-------------------------------|-------------------------|
| 4.6.1 Required Tools: | Similar to removal. |
| 4.6.2 Parts required: | By the use of material |
| 4.6.3 Level of Maintenance: | Heavy |
| 4.6.4 Certification required: | A&P Mechanic |

The wing installation in general has to be carried out in reverse order to removal but we strongly recommend to read the following instructions prior to starting the installation:

4.7 Installing strut to wing

Connect main strut first to the wing and support as suitable, so that no damage occurs to the attachment and strut bearing. In figure 4-3. the correct installation of the strut-wing connection is given. Take care that the leading edge of the profiled main strut is pointing forward. It may be helpful to apply a small amount of grease to both chamfered washers prior to the installation. Take care to ensure correct orientation of the washers, otherwise the folding mechanism of the wings will not operate properly and this may cause damage to the strut.

Caution

Watch for the correct installation of the chamfered washers as shown in figure 4-3. Damage to the struts may occur and folding of the wings will not be possible if those washers are installed in a wrong way!
Tighten fixing bolt to max. torque of 24 Nm / 212 inlb.

4.8 Installing wing to fuselage

- for this operation 3 people are required
- one worker is required to hold the wing on the leading edge and steady the flaperon. The second worker is required to support the wing and flaperon at their roots. The third worker is needed to attach the wing strut.
- Bolt the wing to the fuselage as shown in figure 4-3 (C)
- After the wing is installed, attach the main strut, ensuring correct direction, then install the support struts as shown in figures 4-2 and 4-3.
- Finally reconnect all fuel hoses and wiring for position and strobe lighting.

Caution

DO NOT REUSE SELF-LOCKING NUTS!

4.9 Wing struts

4.10 Description

The wings are attached to the fuselage by suspension points of load-carrying tubes in the upper section of the wing and are anchored by „V“ struts to the bottom fuselage edge. The system of attachment uses an axle common for the wing rear suspension and the strut enables it to swing the wings simply backward lengthwise along the fuselage, thus reducing demands on storage space and road transport.

4.11 Removal and installation

(Refer to paragraph 4.4 and 4.6)

Warning

Wing strut repair is not permitted, if any damage to the strut is detected, the complete strut assembly has to be replaced.

4.12 Tail unit

4.13 Description

The tail unit is of the conventional arrangement with its load-bearing frame welded using steel tubes. A fabric-covered rudder is fixed to the tail by three hinges. The rudder control cables are connected to the bottom of the Rudder. The horizontal stabilizer is supported on both sides by struts attached to the lower / rear fuselage section. The elevator with its one piece leading edge (singular tube) is attached by five suspension points in total, with the drive located in the middle. All the rudder, stabilizer and elevator surfaces are fabric-covered.

4.14 Removal and installation

- | | |
|--------------------------------|-------------------------|
| 4.14.1 Required Tools: | Similar to removal. |
| 4.14.2 Parts required: | By the use material |
| 4.14.3 Level of Maintenance: | Heavy |
| 4.14.4 Certification required: | A&P Mechanic |

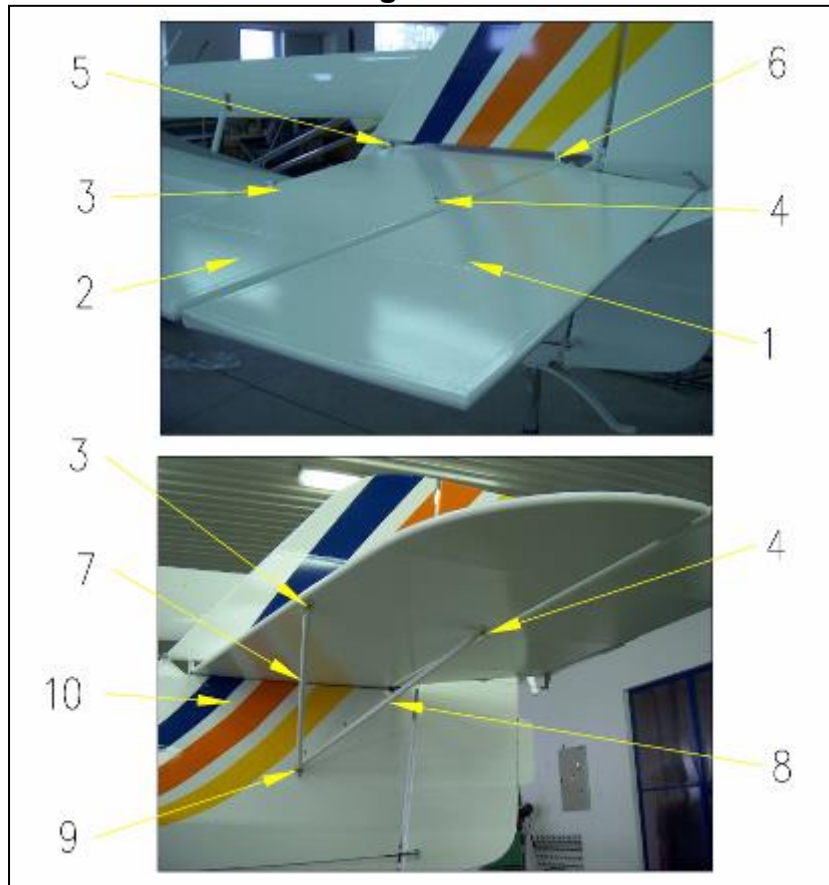
Figure 4-4

1. Elevator
2. Stabiletor
3. Fixing bolt between front strut and stabilizer
4. Fixing bolt between Retral strut and stabilizer
5. Front holder
6. retral holder
7. Front stabilizer strut
8. Retral stabilizer strut
9. Fuselage holder for struts
10. Covering plate under stabilizer

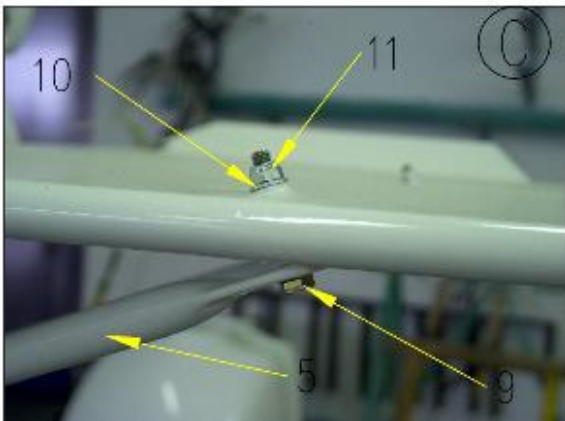
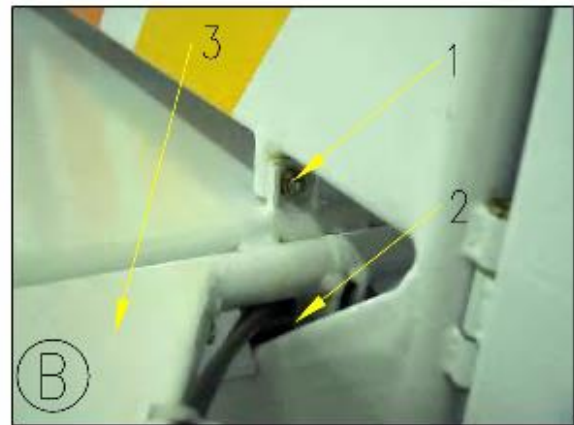
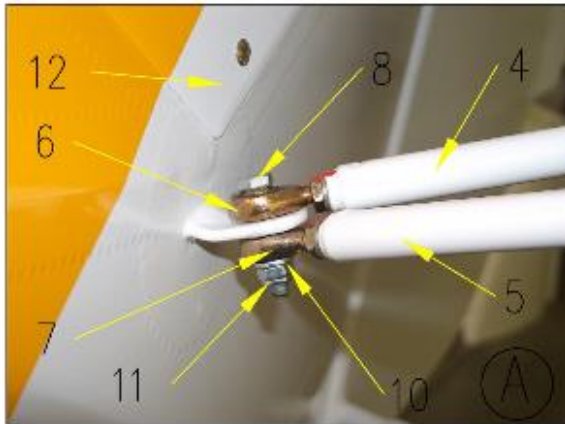
Figure 4-5

A. Fuselage holder for struts
 B. Retrall holder
 C. Fixing bolt between front strut and stabilizer

1. Screw for fuselage and stabilizer
2. Lever for elevator control
3. Elevator
4. Retrall strut
5. Front strut
6. Male threaded shank for retrall strut
7. Male threaded shank for front strut
8. Screw for fuselage and strut
9. Screw for stabilizer and strut
10. Washer
11. Self-locking nut

- a. Remove the plate covering on the fuselage under the stabilizer. Disconnect route of the elevator trim. see figure 4-4 N.10
- b. Disconnect the five hinges between stabilizer and elevator.
- c. Unscrew and remove all struts and holders shown in figure 4-4 N.3, 4, 5, 6, 9
- d. Disconnect and remove the elevator control rod.
- e. Remove elevator from fuselage
- f. For re-installation repeat the above in the reverse order

Caution	DO NOT REUSE SELF-LOCKING NUTS!
----------------	--

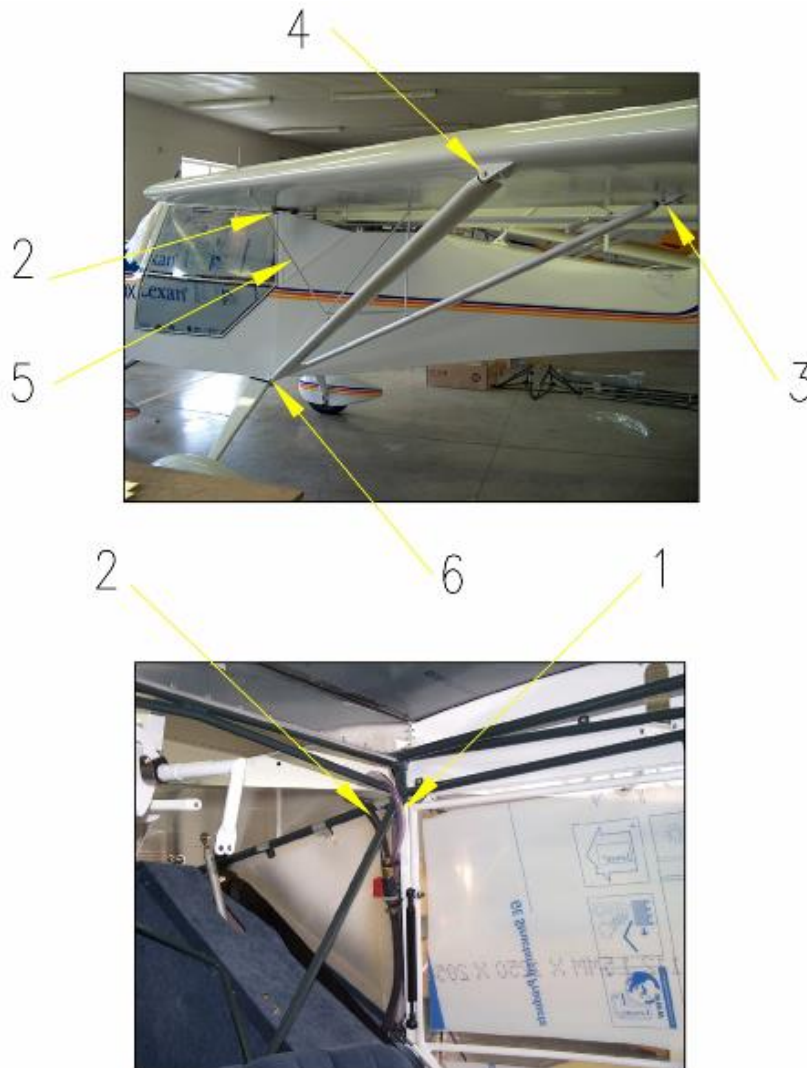
Figure 4-2

1. Pitot line at fuselage
2. Fuel pipe
3. Retral strut-wing connection
4. Front strut-wing connection
5. Support strut
6. Strut-fueslage connection

Section 5

Structures – Landing Gear and Brakes

Table of Contents		Page
5.1	Landing Gear	5-1
5.2	General Description	5-1
5.3	Trouble Shooting	5-1
5.4	Main Gear	5-1
5.5	Removal and Installation.....	5-3
5.6	Repair.....	5-3
5.7	Main Wheel Removal.....	5-3
5.8	Main Wheel Disassembly	5-5
5.9	Inspection and Repair	5-5
5.10	Main Wheel Reassembly	5-6
5.11	Nose Gear	5-6
5.12	Removal and Installation.....	5-6
5.13	Repair.....	5-7
5.14	Nose Wheel Removal and Installation.....	5-7
5.15	Disassembly.....	5-7
5.16	Inspection and Repair.....	5-7
5.17	Reassembly.....	5-9
5.18	System Wheel Balancing.....	5-9
5.19	Nose Wheel Steering.....	5-9
5.20	Steering Adjustment.....	5-9
5.21	Brake System	5-10
5.22	General Description.....	5-10
5.23	Trouble Shooting.....	5-10
5.24	Brake Master Cylinder.....	5-10
5.25	Removal and Installation.....	5-11
5.26	Repair.....	5-12
5.27	Hydraulic Brake Hoses.....	5-12
5.28	Wheel Brake Assemblies.....	5-12
5.29	Removal.....	5-12
5.30	Inspection and Repair.....	5-12
5.31	Reassembly.....	5-13
5.32	Installation.....	5-13
5.33	Checking Brake Lining Wear.....	5-13
5.34	Brake Lining Installation	5-13
5.35	Brake System Bleeding.....	5-13
5.36	Parking Brake System.....	5-14

5.1 Landing Gear

5.2 General Description

The EuroFox has a tricycle undercarriage with a controllable nose wheel. The main landing gear is formed of lever-type swinging legs of laminate, Wheels with low-pressure tires of 14x4 size are provided with hydraulic disc brakes operated from control lever located on the instrument panel. The nose-wheel landing gear is constructed by welded steel tubes. The nose wheel is equipped with a 12x4 sized tire.

5.3 Trouble Shooting

Trouble	Probable Cause	Remedy
Aircraft leans to one side	Incorrect tire inflation	Inflate to pressure specified in figure 1-1.
Tires wears excessively	Incorrect tire inflation	Inflate to pressure specified in figure 1-1.
	Dragging brakes	Refer to paragraph 5.28.
	Wheel bearing damaged	Install new part (s)
	Wheels out of balance	Correct in accordance with paragraph 5.22.
Wheel bounce evident on smooth surface	Out of balance condition	Correct in accordance with paragraph 5.22.

5.4 Main Gear

Figure 5-1. illustrates the main landing gear. The illustrations should be used in conjunction with the following procedures during removal and installation of component parts. Disassembly, inspection and repair, and reassembly of the main undercarriage configurations are described in separate paragraphs for each configuration. The webbed wheels having two aluminum flanges and a hub that are manufactured by an Aeropro supplier. The flanges are attached to the wheel hub by thru-bolts and nuts as shown in figure 5-2. During assembly of the main wheel the thru-bolts or capscrews, as applicable, shall be tightened evenly and torqued to the value specified in figure 5-2.

Figure 5-1

1. Main undercarrage legs
2. Main wheel assembly
3. Wheel fairing
4. Brake
5. Main holder
6. Screw for main holder 2xM8
7. Rubber template
8. Safety wire
9. Bolt for holder on fuselage
10. Washer
11. Nut
12. Cotter pin

5.5 Removal and Installation

- 5.5.1 Required Tools: 10/11/17 mm wrench, phillips head screwdriver, wire cutting pliers, bleed kit.
- 5.5.2 Parts required: 2 x cotter pin (2 x 25 mm).
- 5.5.3 Level of Maintenance: **Heavy**
- 5.5.4 Certification required: **A&P Mechanic**

The following procedural steps remove the landing gear as a complete assembly.

Refer to applicable paragraphs for removal of the individual components. You continue according to Figure 5-1

1. We lift aeroplane and remove seat
2. Remove the wheels spats
3. Remove cable ties securing the brake line distributor to the fuselage (accessible when baggage compartment is removed).
4. Drain hydraulic brake fluid from brake lines.
5. Disconnect hydraulic brake line at the brake line distributor.
6. Hoist or jack aircraft in accordance with figure 5-1
7. Remove both bolts attaching main gear to fuselage.
8. Remove main gear assembly.

Installation of the main gear has to be carried out in reversed order to removal.

5.6 Repair of fuselage and wheels fairings

- 5.6.1 Required Tools: As required
- 5.6.2 Parts required: Epoxy Resin, glass fiber tape, rovings, fabrics.
- 5.6.3 Level of Maintenance: **Heavy**
- 5.6.4 Certification required: **A&P Mechanic**

Repair of main gear is limited to the repair of the wheel fairings. If cracks are detected in the glass fiber fairings, they may be repaired using L285 Epoxy Resin or similar (R&G L20), reinforcing with suitable carbon fiber fabrics. Follow the instructions on the container for a successful completion of the repair. If cracks in the undercarriage legs are present, the main gear has to be replaced, except if cracks are only related to the paint finish. If in doubt, always replace the main gear.

5.7 Main Wheel Removal

- 5.7.1 Required Tools: 11/17/19 mm wrench, wire cutting pliers, plastic hose.
- 5.7.2 Parts required: None
- 5.7.3 Level of Maintenance: **Line**
- 5.7.4 Certification required: **Repairman Maintenance or Owner**

To remove main wheel follow steps 1 and 3, outlined in paragraph 5.5 and then proceed as described below (refer to figure 5-2.):

Figure 5-2



- 1, 2, 3. Screw for fitting brake disc
4. Nut on the main wheel axis
5. 6x screw M6
6. Wheel half include Wheel hub
7. Wheel half

-
- a. Hoist or jack aircraft in accordance with Section 2.
 - b. Remove wheel axis from the wheel fairing.

- c. Withdraw main wheel assembly from the wheel fairing.
- d. Deflate the tyre, remove thru-bolts and separate wheel halves, removing tire, tube, hub and torque plate.
- e. Remove wheel bearings from wheel hub.

Note	If tire, brake pads or brake disc have to be replaced, it is not necessary to drain and disconnect the brake line.
-------------	--

5.8 Main wheel disassembly

- 5.8.1 Required Tools: 2 x 6mm wrench,
- 5.8.2 Parts required: None
- 5.8.3 Level of Maintenance: **Light**
- 5.8.4 Certification required: **Repairman Maintenance**

- a. Remove valve core and deflate tire. Break tire beads loose from wheel rims.

Warning	Injury can result from attempting to separate wheel halves with the tire inflated. Avoid damaging wheel flanges when breaking tire beads loose. A scratch, gouge, or nick may cause wheel failure.
----------------	--

- b. Remove thru-bolts and separate wheel halves, removing tire, tube, hub and torque plate.
- c. Remove wheel bearings from tire

5.9 Main wheel inspection and repair

- 5.9.1 Required Tools: Depending on condition
- 5.9.2 Parts required: Depending on condition
- 5.9.3 Level of Maintenance: **Light**
- 5.9.4 Certification required: **A&P**

- a. Clean all metal parts in solvent and dry thoroughly.
- b. Inspect wheel halves for cracks. Cracked wheel halves shall be discarded and new parts used. Sand out nicks, gouges, and corroded areas. When the protective coating has been removed, the area should be cleaned thoroughly, primed with zinc chromate and painted with aluminum lacquer.
- c. If excessively warped or scored, or worn to a thickness of 0.160-inch, brake disc should be replaced with a new part. Sand smooth small nicks and scratches.
- d. Carefully inspect bearings for damage and discoloration or noises when rotating.

Note	Do not try to re-lubricate the sealed bearings. If in doubt about bearing condition, replace bearings.
-------------	--

5.10 Main Wheel Reassembly.

- 5.10.1 Required Tools: 2x 6 mm wrench.
 5.10.2 Parts required: Loctite 243 (medium strength), 6 x self-locking nut (M6), safety wire (1.0 mm).
 5.10.3 Level of Maintenance: **Light**
 5.10.4 Certification required: **Repairman Maintenance**

- a. Insert wheel bearing to the wheel hub.
- b. Insert thru-bolts through wheel hub, wheel half.
- c. Position tire and tube on outboard wheel half with the tube inflation valve through the hole in wheel half.
- d. Place the outboard wheel half to position on inboard wheel half. Apply a light force to bring wheel halves together.
- e. While maintaining the light force assemble a washer and nut on one thru-bolt and tighten snugly.
- f. Assemble the remaining washers and nuts on the thru-bolts and torque to 88 in. lb. (10 Nm). Use Loctite 243 to secure nuts.

Caution

Uneven or improper torque of thru-bolt nuts can cause failure of bolts, with resultant wheel failure.

Note

It may be helpful when bleeding all air off the hydraulic system, to lower the aircrafts tail.

Caution

Do not use aircraft hydraulic fluid, doing so will cause damage to the cylinder seals. Yellow automobile brake fluid must be used only.

5.11 Nose Gear (see Figure 5-3)

5.12 Removal and Installation

- 5.12.1 Required Tools: Screwdriver, 8/10/17 mm wrench.
 5.12.2 Parts required: Self-locking nut (M6), 2 x self-locking nut (M5), and safety-wire (1.0 mm).
 5.12.3 Level of Maintenance: **Heavy**
 5.12.4 Certification required: **A&P Mechanic**

- a. Remove engine cowling for access.
- b. Weight or tie-down tail of aircraft to raise nose wheel off the floor.
- c. Remove control bowden cable from nosewheel fork
- d. To be disconnected the control Bowden cables from the front steering fork and pull them out of the grips on the lower part of the undercarriage leg.

- e. The front wheel to be under laid so that it is freely suspended on the washer and the cable stop is to be loosened
- f. to locate an absorber of the front leg through the binding cable so that it does not throw out and the bottom absorber pin on the front leg to be disconnected
- g. Disconnect the absorber stop from undercarriage leg.
- h. Unscrew the 4 x screws that hold the bearings on the front undercarriage leg.

5.13 Repair

If damage to any of the nose gear parts is detected then replace the affected parts, no part of the nose gear assembly can be repaired.

5.14 Nose Wheel Removal and Installation

5.15 Disassembly

- 5.19.1 Required Tools: 10 & 17 mm wrench.
- 5.19.2 Parts required: None
- 5.19.3 Level of Maintenance: **Light**
- 5.19.4 Certification required: Repairman Maintenance or Owner

- a. Remove nose wheel axle from wheel fairing then withdraw wheel from fairing.

Note	Remember position of spacers for reassembly.
-------------	--

- b. Remove valve cover and deflate tire. Break tire beads loose from wheel rims. Injury can result from attempting to separate wheel halves with the tire inflated. Avoid damaging wheel flanges when breaking tire beads loose. Any scratches, gouges, or nicks may cause wheel failure.
- c. Remove thru-bolts and separate wheel halves, removing tire, tube and hub.

5.16 Inspection and Repair

- 5.20.1 Required Tools: Depending on condition
 - 5.20.2 Parts required: Depending on condition
 - 5.20.3 Level of Maintenance: **Line**
 - 5.20.4 Certification required: **A&P Mechanic**
- a. Clean all metal parts in solvent and dry thoroughly.
 - b. Inspect wheel halves for cracks. Cracked wheel halves shall be discarded and new parts used. Sand out nicks, gouges, and corroded areas. When the protective coating has been removed, the area should be cleaned thoroughly, primed with zinc chromate and painted with aluminum lacquer.
 - c. Carefully inspect bearings for damage and discoloration or noises when rotating. Do not try to re-lubricate the sealed bearings. If in doubt about bearing condition, replace bearings.

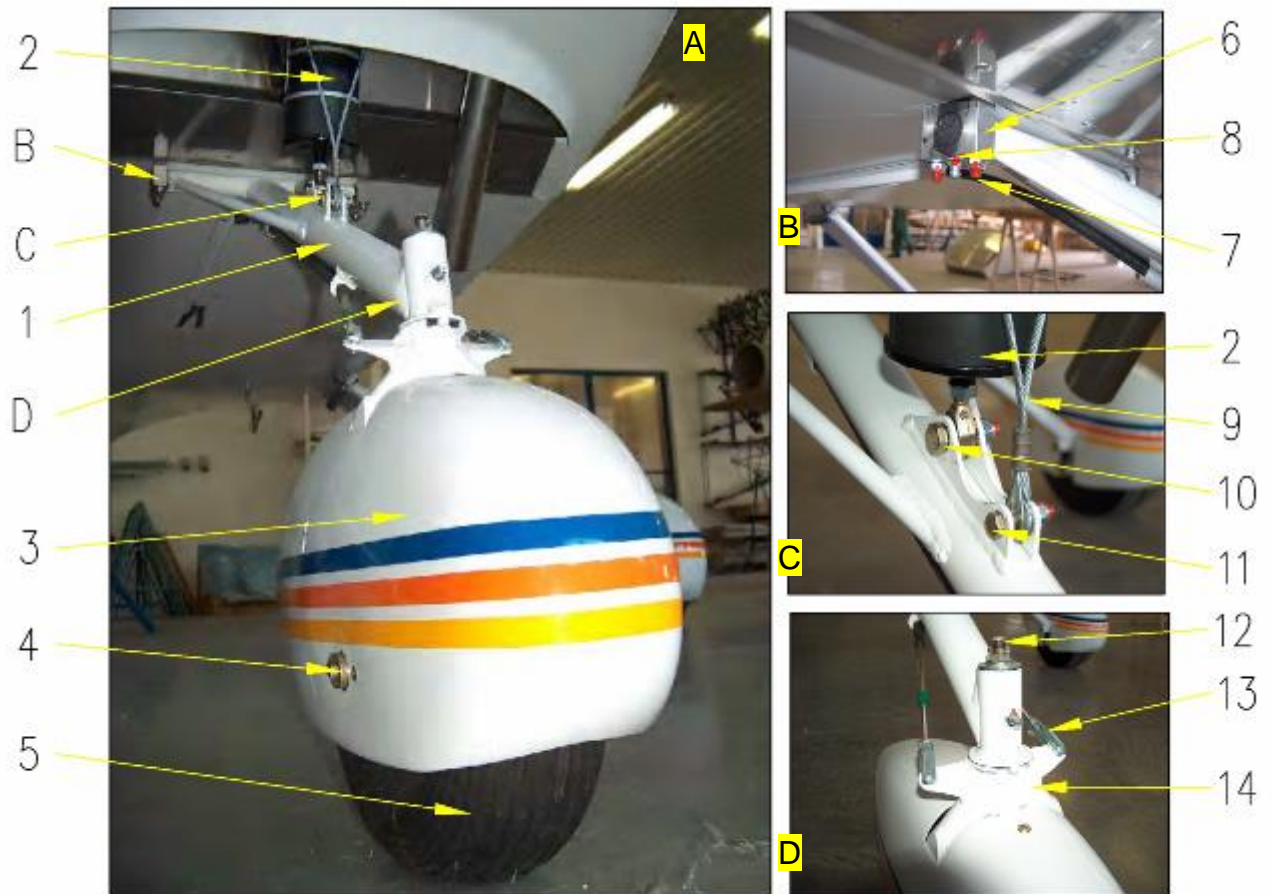
Figure 5-3

- A. Nose gear assembly
- B. Assembly main bearing for holder of nose gear
- C. Holder for shock absorber and stop of nose leg
- D. Control lever of nose leg
- 1. Nose leg
- 2. Shock absorber
- 3. Wheel fairing
- 4. Axis nose wheel
- 5. Nose wheel
- 6. Holder for bearing
- 7. Screws 4x M6 necessary for two site
- 8. Lubrication cup
- 9. Absorber stop cable
- 10. Pin for shock absorber
- 11. Pin for absorber stop
- 12. Axle fork nose leg
- 13. Control of nose leg
- 14. Fork nose leg

5.17 Reassembly

- 5.21.1 Required Tools: 10 & 17 mm wrench.
5.21.2 Parts required: Loctite 243 (medium strength), 5 x self-locking nut (M6), cotter pin (2 x 40 mm).
5.21.3 Level of Maintenance: **Light**
5.21.4 Certification required: **A&P Mechanic or**
- a. Insert thru-bolts through wheel half.
 - b. Position tire and tube on second wheel half with the tube inflation valve through hole in wheel half.
 - c. Place one wheel half to position on other wheel half. Apply a light force to bring wheel halves together.
 - d. While maintaining the light force assemble a washer and nut on one thru-bolt and tighten snugly.
 - e. Assemble the remaining washers and nuts on the thru-bolts and torque to 88 in. lb. (10 Nm). Use Loctite 243 to secure nuts.
 - f. Press one wheel bearing into wheel hub, ensure to place spacer into the wheel hub before installing the second bearing to the hub.

Caution

Uneven or improper torque of thru-bolt nuts can cause failure of bolts, with resultant wheel failure.

5.18 Wheel balancing

Since uneven tire wear is usually the cause of wheel unbalance, replacing the tire probably will correct this condition. Tire and tube manufacturing tolerances permit a specified amount of static unbalance. If a wheel shows evidence of unbalance during service, it may be statically balanced.

5.19 Nose wheel steering system

Nose wheel steering is accomplished through the bowden cables which are connected to the rudder pedals. Steering rod assemblies connect the nose gear steering.

5.20 Steering adjustment

Since the nose wheel steering and rudder system are interconnected, adjustment to one system may affect the other system. Section 10 of this manual contains rigging instructions for the rudder system as well as the nose wheel steering system.

5.21 Brake system

5.22 General description

The hydraulic brake system consists of a master cylinders, located on the pedals. A brake hose connects the master cylinders to a distributor, located behind the cabin bulkhead. Two brake hoses run from the distributor to each wheel brake cylinder.

5.23 Trouble shooting

Trouble	Probable Cause	Remedy
Dragging Brakes	Brake lever binding.	Check and adjust properly.
	Worn or broken piston return spring (in master cylinder).	Install a new cylinder.
	Restrictions in hydraulic lines or restriction in master cylinder valve.	Drain brake lines and clean inside of the brake line with filtered compressed air.
	Worn, scored or warped brake disc.	Install new disc and brake linings.
	Damaged or accumulated dirt restricting free movement of wheel brake parts.	Clean and repair or install new parts as necessary.
Brakes Fail to Operate	Leak in system.	Install new parts.
	Air in system.	Bleed system.
	Lack of fluid in master cylinder.	Fill and bleed system.
	Master cylinder defective.	Install a new cylinder.

(refer to figure 5-4.)

The brake master cylinder, located on the pedals, is activated by gently pushing on the brake pedals positioned on the cockpit floor. A small reservoir is incorporated onto the master cylinder for the fluid supply.

Figure 5-4

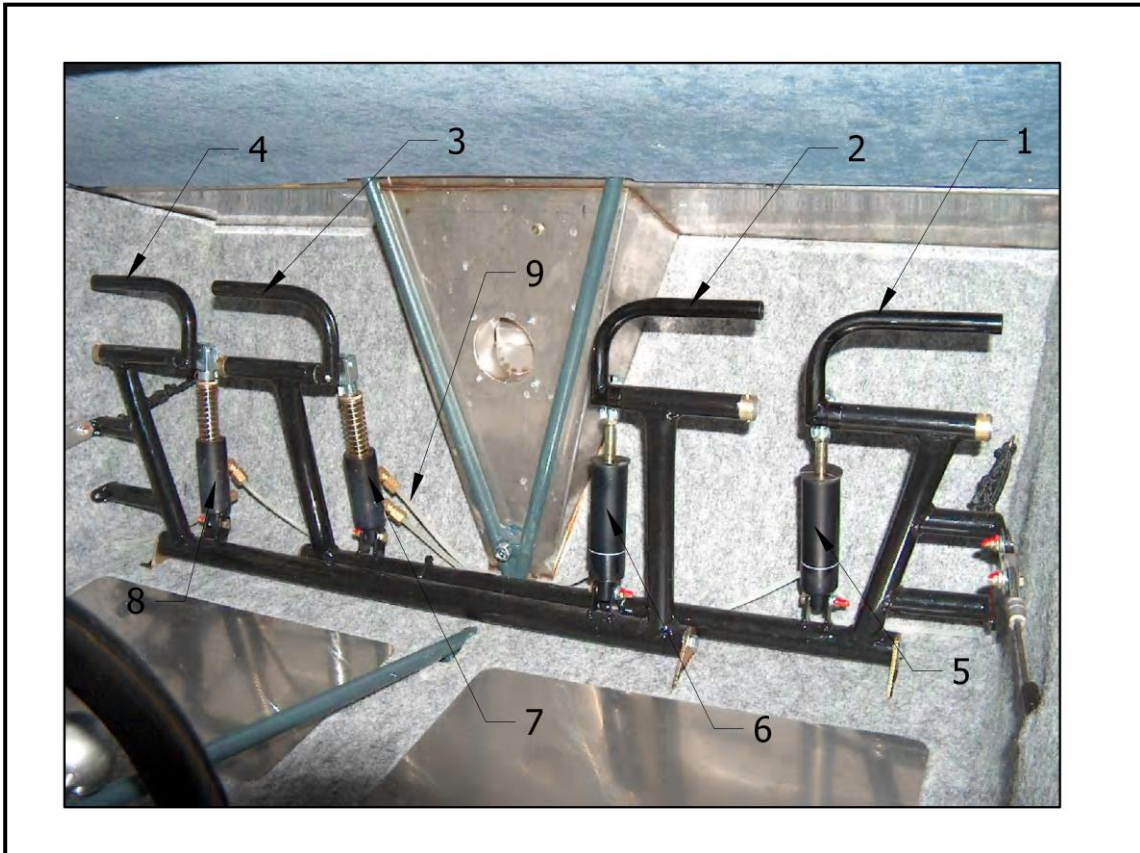

1. Brake pedal on the right side
2. Brake pedal on the right side
3. Brake pedal on the left side
4. Brake pedal on the left side
5. Master cylinder with fluid container for right wheel
6. Master cylinder with fluid container for left wheel
7. Master cylinder for right wheel
8. Master cylinder for left wheel
9. Hydraulic tube for connection master cylinder and brake

5.25 Removal and installation

- | | |
|--------------------------------|--|
| 5.29.1 Required Tools: | Head screwdriver, 10 & 13 mm wrench. |
| 5.29.2 Parts required: | Bleed kit |
| 5.29.3 Level of Maintenance: | Light |
| 5.29.4 Certification required: | A&P Mechanic or LSA Repairman
Maintenance |

- a. Drain the brake fluid and disconnect the distributing tubes see. 9
- b. Unscrew the screw for gripping the casing of the break cylinder.

5.26 Repair

The master cylinder is limited to cleaning, always install a new master cylinder if any defects are detected. Use automobile clean hydraulic fluid or new Yellow car brake fluid.

Caution

Do not use aircraft hydraulic fluid because this will damage the master cylinder sealings.

5.27 Hydraulic brake hoses

All hydraulic hoses used for the brake system are flexible plastic hoses. All hoses provide appropriate connectors to provide an easy replacement.

5.28 Wheel brake assemblies

The wheel brake assemblies use a disc which is attached to the main wheel fixed by the thru-bolts and a floating brake assembly, when the aircraft is equipped with the standard AEROPRO brakes.

5.29 Removal

To remove brake system from the wheel, refer to figure 5-2 and paragraphs 5.7 and 5.8 when the aircraft is equipped with AEROPRO brakes. Drain hydraulic fluid from brake hoses prior to disconnecting the brake assembly.

After the brake assembly is disconnected you can remove disc and brake linings from the assembly.

5.30 Inspection and repair

5.34.1 Required Tools:	Depending on condition
5.34.2 Parts required:	Depending on condition
5.34.3 Level of Maintenance:	Light
5.34.4 Certification required:	A&P Mechanic or LSA Repairman Maintenance

- a. Clean all parts except the brake linings and O-rings with a dry cleaning solvent and dry thoroughly.
- b. New O-rings are usually installed each time they are removed. If O-ring re-use is necessary, they should be wiped with a clean cloth saturated in new automobile hydraulic fluid (Yellow for car) and inspected for damage.

Note

Thorough cleaning is important. Dirt and chips are the most common cause of malfunctions in the hydraulic brake system.

- c. Check brake lining for deterioration and maximum permissible wear. See paragraph 5.37.
- d. Inspect brake cylinder bore for scoring. A scored cylinder will leak or cause rapid O-ring wear. Install new brake cylinder if scoring is found.
- e. If the anchor bolts on the brake assembly are nicked or gouged, they should be sanded smooth to prevent binding with the pressure plate or torque plate.
- f. Inspect wheel brake disc for a minimum thickness of 0.118-inch. If brake disc is below minimum thickness, replace the disc.

5.31 Reassembly

Lubricate parts with clean yellow automobile brake fluid and assemble components with clean automobile yellow car brake fluid and assemble components with care to prevent damage to O-rings.

5.32 Installation

Installation of wheel brake assembly is done in reversed order to removal, refer to paragraph 5.33.

5.33 Check brake lining wear

New brake lining should be installed when the current lining is worn to a minimum thickness of 0.118 inch. Visually compare 118 inch strip of material held adjacent to each lining to measure the thickness of the lining.

5.34 Brake lining installation

5.34.1 Required Tools:	None
5.34.2 Parts required:	Brake Linings, Copper Grease
5.34.3 Level of Maintenance:	Light
5.34.4 Certification required:	LSA Repairman Maintenance or Owner

- a. Pull out back plate.
- b. Apply copper grease to back plate and piston, replace brake linings.

5.35 Brake system bleeding

5.35.1 Required Tools:	11 mm wrench, bleed kit.
5.35.2 Parts required:	Yellow car brake fluid
5.35.3 Level of Maintenance:	Light
5.35.4 Certification required:	LSA Repairman Maintenance

Bleeding with a clean hydraulic pressure source connected to the wheel cylinder bleeder is recommended.

- a. Remove brake master cylinder filler plug and screw flexible hose with appropriate fitting into the filler hole at top of the master cylinder.
- b. Immerse the free end of the flexible hose in a container with enough hydraulic fluid to cover the end of the hose.
- c. Connect a clean hydraulic pressure source, such as a hydraulic hand pump or Hydro Fill unit, to the bleeder valve in the wheel cylinder.
- d. As fluid is pumped into the system, observe the immersed end of the hose at the master brake cylinder for evidence of air bubbles being forced from the brake system. When bubbling has ceased, remove bleeder source from wheel cylinder and tighten the bleeder valve.

Note	Ensure that the free end of the hose from the master cylinder remains immersed during the entire bleeding process.
-------------	--

Caution	Do not use aircraft hydraulic fluid because this will damage the master cylinder sealings. Automobile brake fluid must be used only.
----------------	--

5.36 Parking brake system (refer to figure 5-4.)

When using the parking brake the same lever is used as for operating the brake. After pulling the lever as for normal brake operation, (see 2) twisting the lever to the right or left to lock the brake in the on position.

Section 6

Structures – Aileron and flap control system

Table of contents	Page
6.1 <i>Aileron and Flaps Control System</i>	6-0
6.2 Description.....	6-0
6.3 Trouble shooting.....	6-1
6.4 Control stick linkage.....	6-1
6.5 Description.....	6-1
6.6 Removal and installation.....	6-3
6.7 Aileron and flaps control rods.....	6-3
6.8 Description.....	6-3
6.9 Removal and installation.....	6-5
6.10 Bellcranks.....	6-5
6.11 Description.....	6-5
6.12 Removal and installation.....	6-5
6.13 Ailerons and flaps.....	6-5
6.14 Description.....	6-5
6.15 Removal and installation.....	6-5
6.16 Repair.....	6-6
6.17 Rigging.....	6-6

6.1 Aileron and flaps control system

6.2 Description

The aileron control system is comprised of push-pull rods and bellcranks, that which link the control stick to the ailerons.

6.3 Trouble shooting

For some of the remedy procedures in the following trouble shooting chart it may be necessary to re-rig system, and if so then refer to paragraph 6.17.

Trouble	Probable Cause	Remedy
Lost motion in the control stick.	Broken brackets or worn rod end bearings.	Replace worn or broken parts.
	Sprung bellcranks.	Replace bellcrank.
Resistance to the control stick movement.	Bellcranks distorted or damaged.	Replace bellcrank.
Control stick not centering with aileron neutral.	Improper adjustment of aileron push-pull rods.	Adjust in accordance with paragraph 6.17.
Incorrect aileron travel	Push-pull rods not adjusted properly.	Adjust in accordance with paragraph 6.17.
	The control stick adjustment-screws are not adjusted properly.	Adjust in accordance with paragraph 6.17.

6.4 Control stick linkage

6.5 Description

Both control sticks are linked together by a control rod system to ensure synchronized movement. The linkage consists of two bearings connected on the floor of the cabin in front of the seats. A translator connects the control sticks linkage to the aileron linkage, which uses several bellcranks to establish the connection to the control surfaces. An illustration of the aileron system is given in figure 6-1.

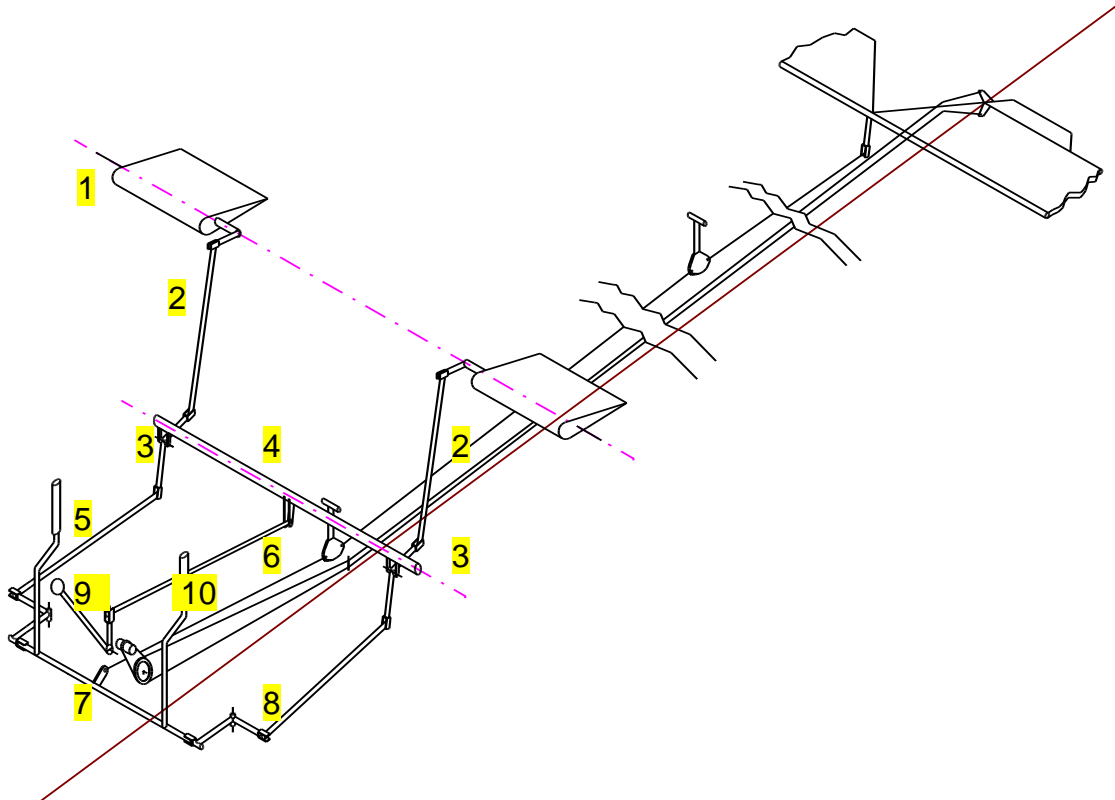
Figure 6-1

1. Ailerons and flaps
2. Rod between flaps and mixer
3. Controls lever
4. Mixer controls lever
5. Rod on the bottom
6. Rod for control of flap
7. Holder of controls Column
8. Controls lever
9. Flap lever
10. Controls stick

6.6 Removal and installation

- 6.6.1 Required Tools: 3/32 allen wrench, 10 mm wrench, wire cutting pliers, soldering iron.
- 6.6.2 Parts required: Cable ties, solder, 3 x self-locking nut (M6).
- 6.6.3 Level of Maintenance: **Heavy**
- 6.6.4 Certification required: **A&P Mechanic or Repairman Maintenance**

In general the control stick linkage needs no regular servicing, due to replacement of other parts of the aileron control system, it may however require readjustment to ensure the correct travel of the ailerons and access to the linkage will be required for this purpose.

- a. Remove seats from the cabin.
- b. Remove the control stick grips and disconnect wiring from the control stick switches.
- c. Remove wiring from the control stick tubes and linkage (remember position of the control stick wiring and cable ties, for reinstallation purposes).

Caution

If the control stick wiring is not installed correctly, binding of the control stick and cracking or chafing of wiring will occur and may cause fire.

Reassembly is done in reverse order to the steps outlined above. Tighten screws and bolts to the torque settings in accordance to the values given in Section 1.

Caution

DO NOT REUSE SELF-LOCKING NUTS.

6.7 Aileron and Flap Control Rods

6.8 Description

Aileron and flap control rods run from the control stick linkage joint through the fuselage to the aileron control surfaces through a series of bellcranks. The whole aileron control rod system requires no regular servicing. For details see Figure 6-2

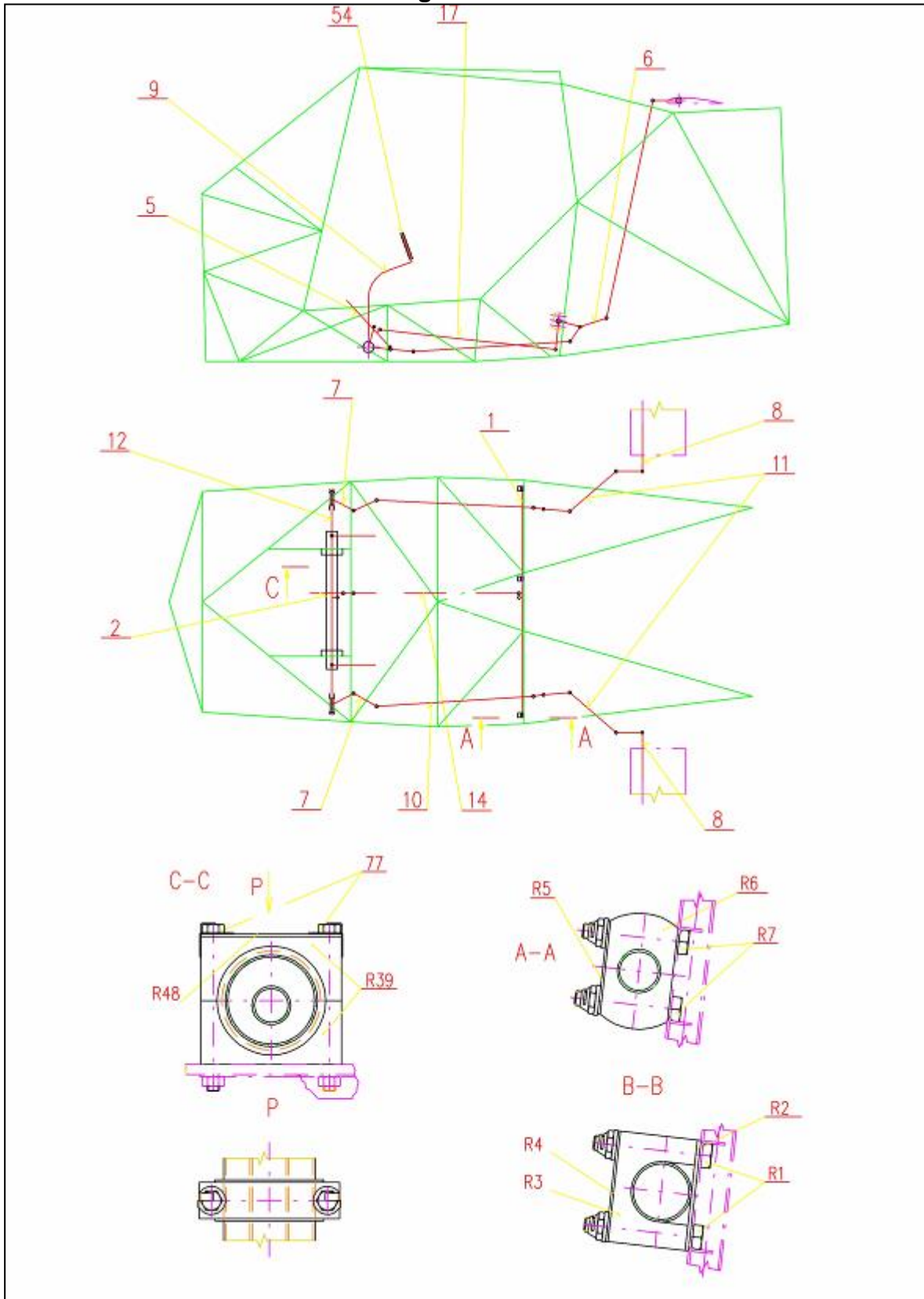
Figure 6-2

6.9 Removal and installation

6.9.1 Required Tools:	10 mm wrench
6.9.2 Parts required:	self-locking nuts as required.
6.9.3 Level of Maintenance:	Heavy
6.9.4 Certification required:	A&P Mechanic or Repairman Maintenance

The ailerons and flaperons control levers are located on the floor in the central part of the cockpit. The motion is transferred via a tie rod to the countershaft for lateral control in the control system of ailerons / flaperons.

Additionally, the center cover (located between the seats) and the control stick floor covers can be removed if required. When it is necessary to replace parts of the control rod system, always use new self-locking nuts and torque to the values given in Section 1.

6.10 Bellcranks

6.11 Description

The aileron and flaps control rod system is driven by various bellcranks located in the fuselage, refer to figure 6-1. for a detailed illustration. Bellcranks need no regular servicing.

6.12 Removal and installation

Refer to paragraph 6.9.

6.13 Ailerons and flaps

6.14 Description

The ailerons are constructed from a fiberglass composite material, hinged to the trailing edge of the wings.

6.15 Removal and installation

6.15.1 Required Tools:	2 pieces 8 mm wrench
6.15.2 Parts required:	10 x self-locking nut (M6)
6.15.3 Level of Maintenance:	Heavy
6.15.4 Certification required:	A&P Mechanic or Repairman Maintenance

- a. Disconnect the aileron rods.
- b. Remove screws and nuts attaching aileron hinges to 5 holders of the trailing edge of the wing.
- c. Using care, detach the aileron from the wing and fuselage.
- d. Install aileron in reverse order to the preceding steps.
- e. Secure outboard hinge screw with safety-wire.

- f. If rigging was correct and the push-pull rod adjustment was not disturbed, it should not be necessary to rig system. Otherwise rig aileron system in accordance with paragraph 6.17.

Caution Use new self-locking nuts and torque to the values given in Section 1.

6.16 Repair

Repair is limited to replacing the copper bushings or hinge bolts and restoring dents or smaller cracks on edges. Since ailerons are designed as a sandwich construction, it is strongly recommended to replace or return to factory for repair, if significant damage is detected on the aileron structure.

6.17 Rigging

- | | |
|-------------------------------------|--|
| 6.17.1 Required Tools: | 10 & 13 mm wrench, screwdriver, Jig for adjustment |
| 6.17.2 Parts required:
required. | Safety wire, self-locking nuts as required. |
| 6.17.3 Level of Maintenance: | Heavy |
| 6.17.4 Certification required: | A&P Mechanic or Repairman Maintenance |
- a. For the flaperon control levers to apply the correct range of input but will stabilize in the neutral position, (pattern see 1 pict. 6-2) ensure the control stick and wing flap lever are both set to the neutral position before completing the rig.
- b. Gradually set the length of the rods from the control stick casing up to the rods linked to the ailerons ensuring that both the aileron and control stock are in the neutral position before completing the rig.
- c. Check the maximum deflections of the ailerons and flaperons to make sure the correct range of movement can be reached for both the controls.

Section 7

Structures – Elevator control system

Table of contents	Page
7.1 Elevator control system.....	7-1
7.2 Description.....	7-1
7.3 Trouble shooting.....	7-1
7.4 Elevators.....	7-2
7.5 Removal and installation.....	7-2
7.6 Repair.....	7-2
7.7 Bellcranks.....	7-3
7.8 Removal and installation.....	7-3
7.9 Rigging.....	7-4

7.1 Elevator control system

7.2 Description

The elevator is operated by the forward and rearwards movement input on the control stick, acting through a bellcrank and a push-pull tube. An elevator trim tab is installed on the elevator trailing edge and is described in Section 8.

7.3 Trouble shooting

Note	Due to remedy procedures in the following trouble shooting chart it may be necessary to re-rig the system; if so, refer to paragraph 7.9.
-------------	---

Trouble	Probable Cause	Remedy
No response to control stick fore-and-aft movement.	Quick release connector at aft end of push-pull tube disconnected.	Join quick release connector properly.
	Forward end of push-pull tube disconnected.	Attach push-pull tube correctly.
	Connection between bellcrank and push-pull tube disconnected.	Attach push-pull tube correctly.
Binding or jumpy motion felt in movement of elevator.	Defective bellcrank pivot bearing.	Replace bellcrank bearing.
	Nylon grommet bearings binding.	Replace grommet.

	Defective elevator hinges or lubrication needed.	Replace defective hinges or lubricate per Section 2.
Elevator fails to attain prescribed travel.	Interference beneath center cover or behind rear cabin bulkhead.	Rig system in accordance with paragraph 7.9.

7.4 Elevator

7.5 Removal and installation (refer to figure 4-3 and 4-4)

8.5.1 Required Tools:	According to 4.15
8.5.2 Parts required:	self-locking nut (M8)
8.5.3 Level of Maintenance:	Heavy
8.5.4 Certification required:	A&P Mechanic or Repairman Maintenance

7.6 Repair

The tail unit is of a conventional design with its load-bearing frame welded of steel tubes. A fabric-covered rudder is attached by three hinges. The control lever situated on its underside. The horizontal stabilizer surfaces are braced (both sides) by two struts attached to the bottom edge of the main fuselage. The elevator has a one piece leading edge which is attached to the horizontal stabilizer by five suspension points as a total, with drive arm attached in the middle. The surface of all the horizontal tail unit is fabric-covered.

Repair of elevator skin

If damage occurs under operation, the skin can be repaired by replacing a whole section of the damaged fabric, or for minor damage, by a local repair using a patch. Such repairs may only be carried out using the same materials as used for the aircraft fabrication.

Repairs of the lattice-work

The operator is only allowed to carry out repairs on the lattice-work that does not require either use of any welding equipment or application of thermal treatment for straightening. Straightening of such structural members is permitted however, if the deflection of which does not exceed 3% member length-member diameter ratio. A local deflection (depression) not exceeding 5% of the tube dimension in its diameter can be considered admissible providing the tube is not damaged by cracks or some other non-reversible deformation.

7.7 Bellcrank

7.8 Removal and installation (refer to figure 7-1.)

8.8.1 Required Tools:	head screwdriver, 10 mm wrench.
8.8.2 Parts required:	4 x self-locking nut (M6).

8.8.3 Level of Maintenance:

Heavy

8.8.4 Certification required:

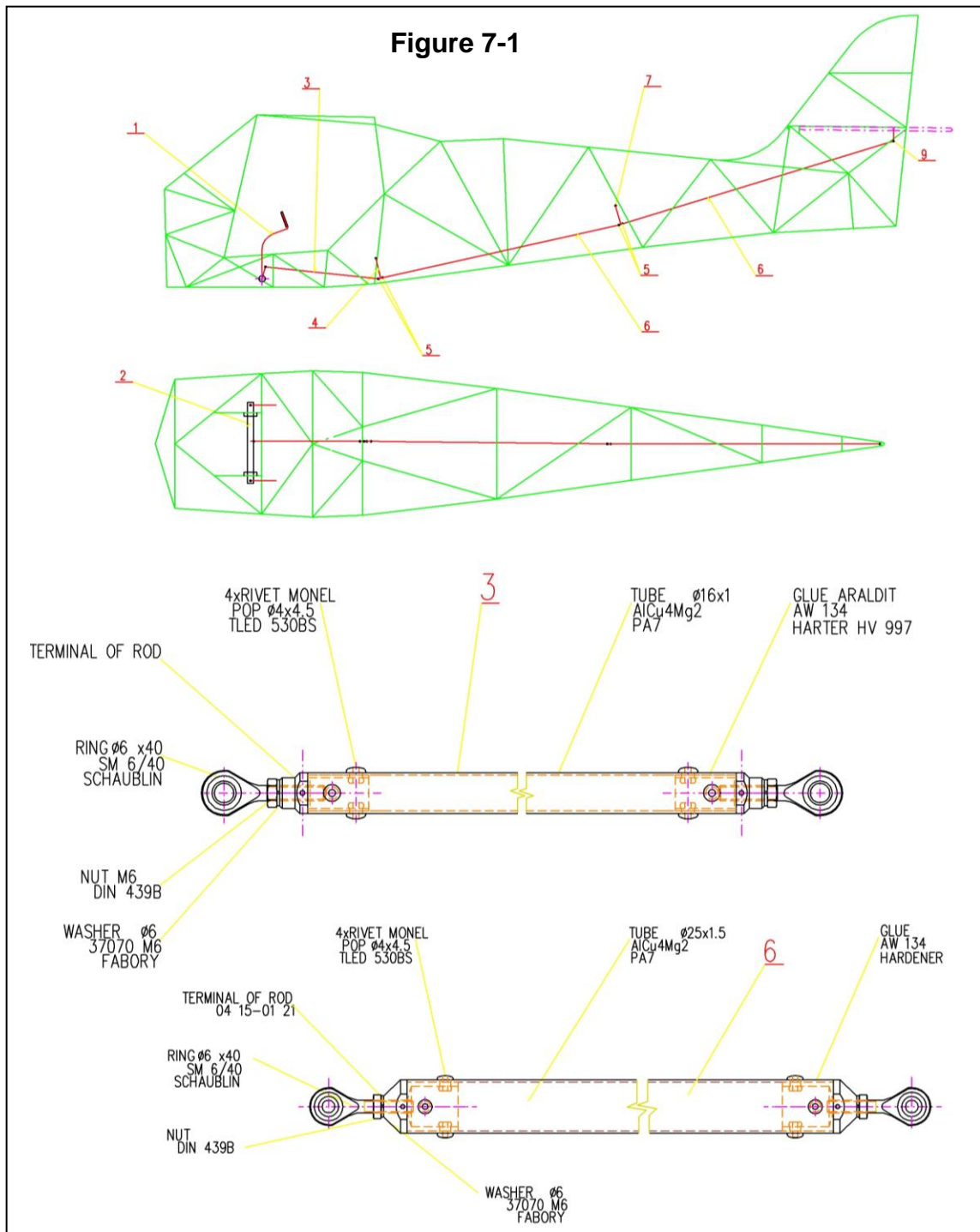
**A&P Mechanic or Repairman
Maintenance**
Figure 7-1

1. Controls stick
 2. Holder controls stick
 3. Short rod
 4. Front bellcrank
 5. Bearing
 6. Long rod
 7. Center bellcrank
 8. Bearing on the elevator
-

- a. Remove pilot seat (refer to Section 3).
- b. Disconnect forward and aft push-pull tube from bellcrank.
- c. Remove pivot bolt and remove bellcrank.
- d. Reverse preceding steps for installation.
- e. Check for free play of push-pull tubes and bellcrank.

7.9 Rigging

8.9.1 Required Tools:	14 mm open-end wrench
8.9.2 Parts required:	Loctite 243 (medium strength)
8.9.3 Level of Maintenance:	Heavy
8.9.4 Certification required:	A&P Mechanic or Repairman Maintenance

- a. Locate neutral position of elevators by streamlining elevators with stabilizer.
- b. Place an inclinometer on the elevator and set to zero.
- c. Check for centered position of control stick.
- d. If required, adjust stick center position at the aft end of push-pull tube and secure with **Loctite 243**.
- e. Check elevator travel as outlined in figure 1-1.

Section 8

Structures – Elevator trim control system

Table of contents		Page
8.1	Elevator trim control system.....	8-0
8.2	Description.....	8-0
8.3	Trouble shooting.....	8-0
8.4	Trim tab.....	8-2
8.5	Inspection and repair.....	8-2
8.6	Trim lever	8-2
8.7	Removal and installation.....	8-2
8.8	Rigging.....	8-4

8.1 Elevator trim control system

8.2 Description

The aircraft trim control Lever is located on the floor on a longitudinal tube and its motion is directed by means of cables and bowden cables to the elevator trim tab.

8.3 Trouble Shooting

Trouble	Probable Cause	Remedy
Trim tab fails to move.	Broken controls cable	Replace cable
	Unconnected cable on the trim tab lever	Check all controls road
Incorrect trim tab travel.	Inside in the bowden is dirt	Check and clean cable and lubricate
	Controls cable is rusty	Removal cable and clean bowden and lubricate

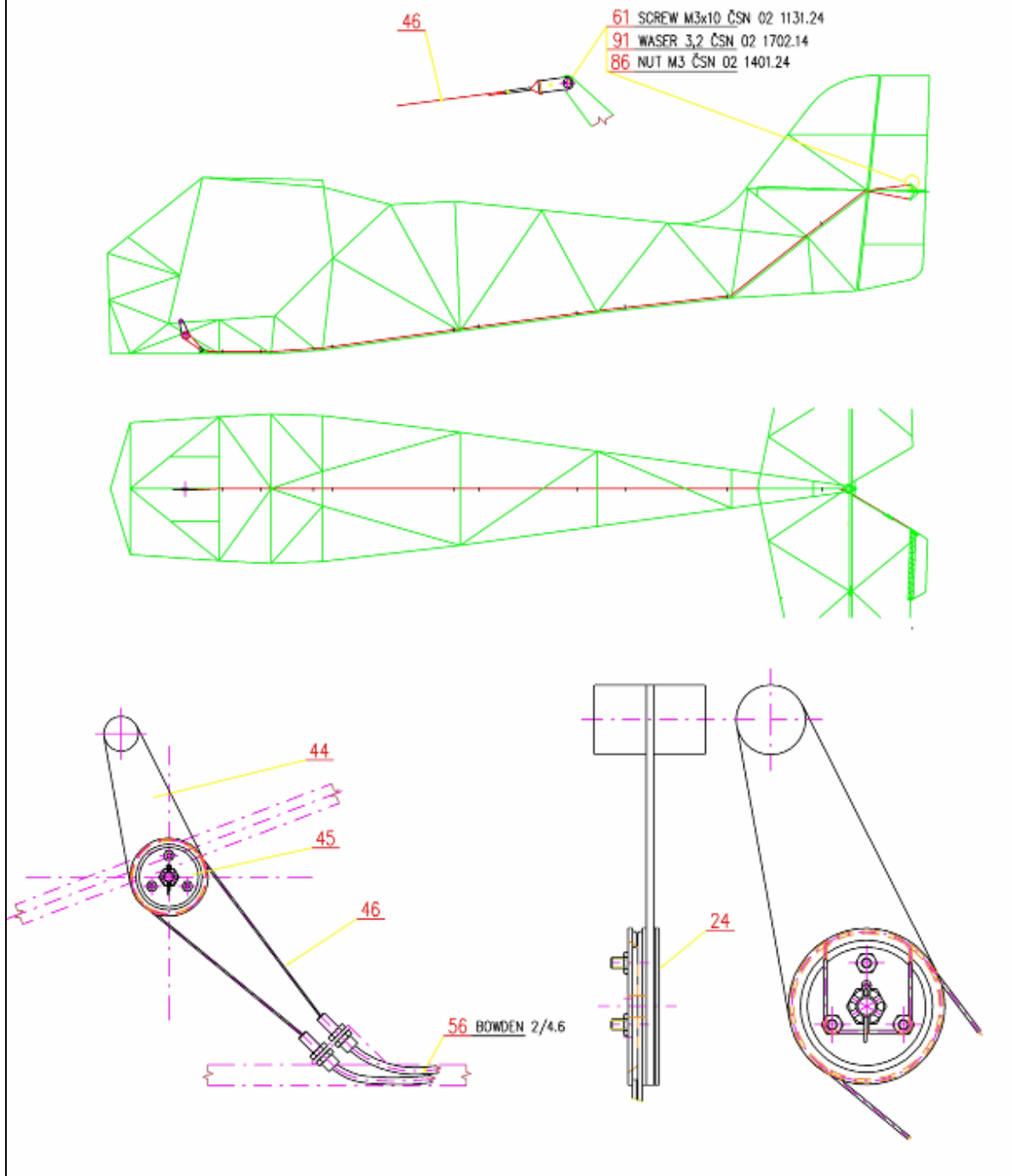
Figure 8-1

24. Leathern circllet
 45. Circllet for holder of cable
 56. Bowden cable
 91. Washer

44. Controls lever
 46. Controls cable
 61. Screw
 86. Nut

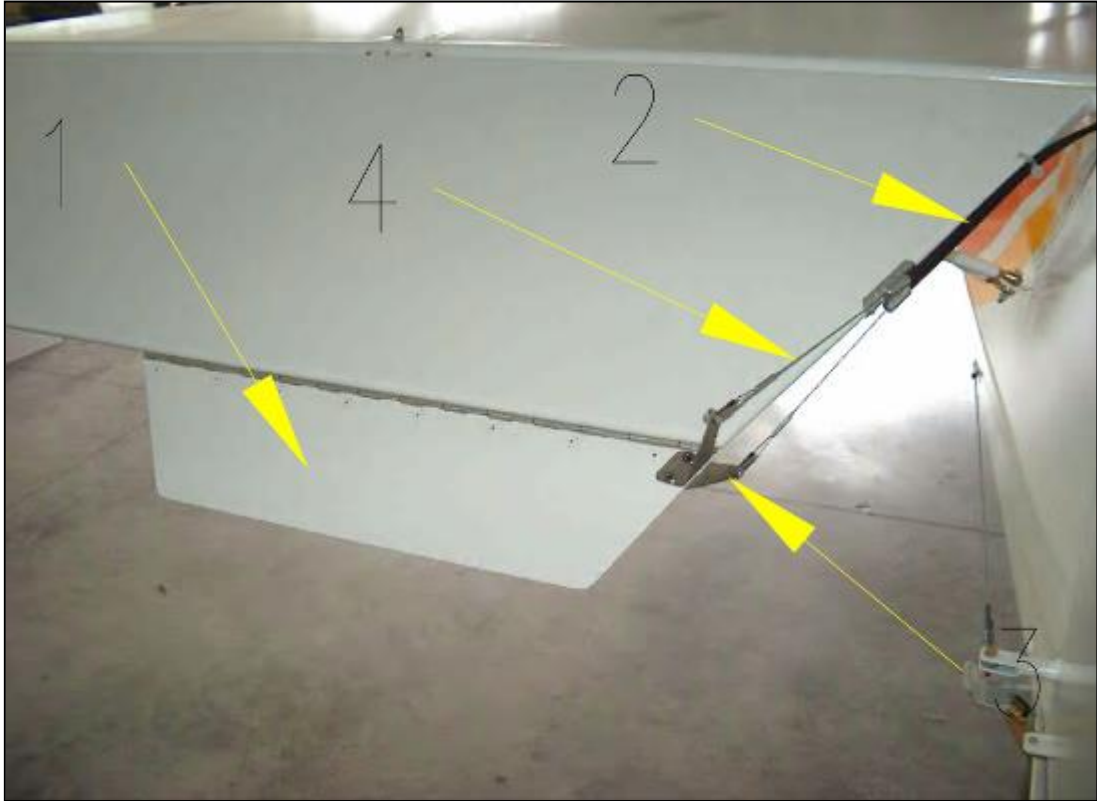
Figure 8-2

1. Trim tab
2. Bowden Cable
3. Lever on the trim tab
4. Control cable

8.4 Trim tab

8.5 Inspection and repair

The trim tab panel is attached to the elevator by an aluminium hinge, therefore it can not be removed from the elevator. The hinge should be inspected for cracks at regular service intervals. If cracks are found in the paint of the hinge, ensure cracks are not structural and if so, will require no further servicing.

8.6 Trim lever

8.7 Removal and installation

- | | |
|-----------------------|-----------------------------------|
| 8.7.1 Required Tools: | screwdriver, 7 mm open-end wrench |
| 8.7.2 Parts required: | Loctite 243 (medium strength) |

8.7.3 Level of Maintenance: **Light**
8.7.4 Certification required: **A&P Mechanic or Repairman Maintenance**

- a. Remove the seats
- b. Unscrew the rod screws of the bowden cable in the cockpit under the seat.
- c. Unscrew the screws of the fork at the end of the cable on the elevator trim. See 3 pict. 8-2
- d. Release the cable and unscrew the securing screw as seen at 45 pict. 8-1
- e. Carefully remove the lever from the cockpit area considering the trim control cable.
- f. Follow the procedures above in the reverse sequence during reinstallation

8.13 Rigging

8.13.1 Required Tools: allen wrench
8.13.2 Parts required: Cotter pin (1.6 x 20 mm)
8.13.3 Level of Maintenance: **Light**
8.13.4 Certification required: **Repairman Maintenance or Owner**

- a. Move controls lever to the center position.
- b. Trim tab must be in the center position
- c. Check for correct movement of trim tab. Pushing the control lever to the "forward" and checking the Trim Tab moves "downward".

Note	Always use a new cotter pin when reestablishing the connection of push-pull rod at the trim tab bracket.
-------------	--

Section 9

Structures – Rudder control system

Table of contents	Page
9.1 Rudder control system.....	9-0
9.2 Description.....	9-0
9.3 Trouble shooting.....	9-0
9.4 Rudder pedal assembly.....	9-1
9.5 Removal and installation.....	9-1
9.6 Rudder.....	9-2
9.7 Removal and installation.....	9-2
9.8 Repair.....	9-2
9.9 Cables and pulleys.....	9-2
9.10 Removal and installation.....	9-2

9.1 Rudder control system

9.2 Description

Rudder control is maintained through the use of conventional rudder pedals which also control nose wheel steering. The system is comprised of rudder pedals, a bellcrank, cables and pulleys, all of which link the pedals to the rudder and nose wheel steering.

Rudder pedals are located in the front of the cockpit on the floor. The pedal motion is transferred by steel cables to the rudder.

9.3 Trouble Shooting

Note	Due to remedy procedures in the following trouble shooting chart it may be necessary to de-rig the system, refer to paragraph 9.11.
-------------	---

Trouble	Probable Cause	Remedy
Rudder does not respond to pedal movement.	Broken or disconnected cables.	Connect or replace cables.
Binding or jumpy movement of rudder pedals.	Cables too tight.	Adjust cable tension in accordance with paragraph 10.11.
	Cables not riding properly on pulleys. Binding, broken or defective pulleys or cable guards.	Route cables correctly over pulleys. Replace defective pulleys and install guards properly.

	Defective pedal bar bearings.	Replace bearings.
	Nose gear strut needs lubrication.	Lubricate copper bushings of nose gear strut.
Lost motion between rudder pedals and rudder.	Insufficient cable tension.	Adjust cable tension in accordance with paragraph 10.11.
Incorrect rudder travel.	Incorrect rigging.	Rig system in accordance with paragraph 10.11.

9.4 Rudder Pedal Assembly (refer to figure 9-1.)

9.5 Removal and Installation

- 9.5.1 Required Tools: 8/10/17 mm wrench.
- 9.5.2 Parts required: self-locking nuts (M6).
- 9.5.3 Level of Maintenance: **Heavy**
- 9.5.4 Certification required: **A&P Mechanic or Repairman Maintenance**

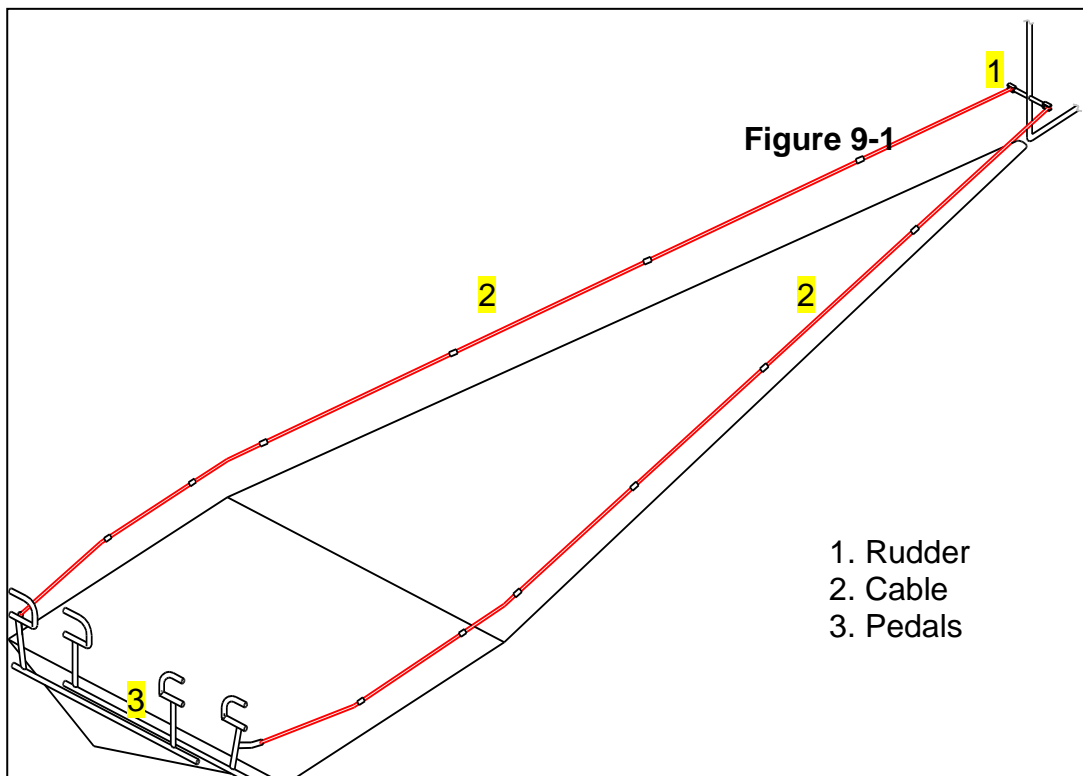

- a. Disconnect cables from rudder pedals.
- b. Disconnect cable for nosewheel control from rudder pedals.
- c. Unscrew brackets from fuselage and remove pedal linkage assemblies.

- d. Reverse preceding steps for reinstallation.
- e. Rig system in accordance with applicable paragraph in this section, safety clevises and reinstall all items removed in step **a** and **b**.

Note	Rudder bar assemblies should be checked for excessive wear before installation. The bearing requires no lubrication unless binding occurs. A few drops of general purpose oil should eliminate such binding.
-------------	--

9.6 Rudder

9.7 Removal and installation

- 9.7.1 Required Tools: 10mm wrench.
- 9.7.2 Parts required: Self-locking nut (M6), safetying
- 9.7.3 Level of Maintenance: **Heavy**
- 9.7.4 Certification required: **A&P Mechanic or Repairman Maintenance**

- c. Disconnect cables from rudder.
- d. Remove all hinge bolts upward to disengage
- e. Reverse preceding steps for installation.
- f. Rig system in accordance with applicable paragraph in this section.

9.8 Repair

If damage occurs under operation, the skin can be repaired by replacing a whole part of the damaged fabric, or by a local repair using a patch. Such repairs may only be carried out using the same materials as applied at aircraft fabrication. (Polyfyber)

9.9 Cables

9.10 Removal and installation

9.10.1 Required Tools: 10 mm wrench, new cable and Nicopress tools

9.10.2 Parts required: 2 x self-locking nut (M6) and 2x M5

9.10.3 Level of Maintenance: **Heavy**

9.10.4 Certification required: **A&P Mechanic or Repairman
Maintenance**

- a. Disconnect cables at rudder pedals.
- b. Disconnect cables at rudder.
- c. Cut cables on the rudder side of the cable and remove cables from the cockpit end.
- d. Only use new cables when carrying out the reinstallation.
- e. When installing the new cable, feed the cable through the cockpit end of the cable at the same point from where it was removed.
- f. When installing the cables you will have to use Nicopress tools to seal the ends of cables, you can prepare the front end outside of fuselage before starting the installation.
- g. Set the rudder pedals in the neutral position and ensure the rudder surface is also set to neutral. Then make sure the cables are of suitable, equal tension. Now secure the second ending by compressing with the Nicopress tool.
- h. Check quality of connections of the cables to rudder and pedals.

WARNING

Be sure rudder moves in correct direction when operated by pedals.

Section 10

Engine

Table of Contents		Page
10.1	Engine Cowling.....	10-2
10.2	Removal and Installation.....	10-2
10.3	Cleaning and Inspection.....	10-4
10.4	Repair.....	10-4
10.5	Engine.....	10-4
10.6	Engine Date	10-4
10.7	Trouble Shooting.....	10-5
10.8	Removal.....	10-8
10.9	Cleaning.....	10-10
10.10	Accessoires Removal.....	10-10
10.11	Inspection	10-11
10.12	Engine Build-Up	10-11
10.13	Installation.....	10-11
10.14	Flexible Fluid Hoses.....	10-13
10.15	Leak Test.....	10-13
10.16	Replacement.....	10-14
10.17	Static Run-Up Procedures.....	10-14
10.18	Engine Mount.....	10-15
10.19	Removal and Installation.....	10-15
10.20	Repair.....	10-15
10.21	Shock-Mount Pads.....	10-15
10.22	Engine Oil System.....	10-15
10.23	Trouble Shooting.....	10-16
10.24	Filter Element Removal and Installation.....	10-17
10.25	Engine Fuel System.....	10-18
10.26	Carburator Removal and Installation.....	10-18
10.27	Idle Speed Adjustment.....	10-19
10.28	Carburetor sychronizing.....	10-19
10.29	Induction Air System.....	10-19
10.30	Removal and Installation.....	10-20
10.31	Iginition System.....	10-20
10.32	Magneto Removal and Installation	10-20
10.33	Magneto Check.....	10-20
10.34	Spark Plugs	10-21
10.35	Engine Controls.....	10-21
10.36	Rigging.....	10-22
10.37	Throttle Control.....	10-23
10.38	Choke Control.....	10-23
10.39	Carburetor Heat Control.....	10-24

Table of Contents (continued)		Page
10.40	Starting System.....	10-24
10.41	Trouble Shooting	10-24
10.42	Removal and Installation	10-25
10.43	Exhaust System.....	10-25
10.44	Removal.....	10-25
10.45	Inspection.....	10-26
10.46	Extreme Weather Maintenance.....	10-27
10.47	Cold Weather.....	10-27
10.48	Hot Weather.....	10-27
10.49	Dusty Conditions.....	10-27
10.50	Seacost and Humid Areas	10-27

10.1 Engine Cowling

The engine cowling is comprised of an upper and lower cowl segment. Quick-release fasteners are used at the cowling fuselage mount attach points to facilitate detachment of the cowling at the firewall. Special screws are used along the side parting surfaces to hold lower cowling and cowling fuselage segments together. Both cowl segments are constructed from carbon fibre composites.

10.2 Removal and Installation

11.2.1 Required Tools:	Screwdriver
11.2.2 Parts required:	None
11.2.3 Level of Maintenance:	Line
11.2.4 Certification required:	Owner

Removal and installation of engine cowling is accomplished by releasing the quick release fasteners at side parting surfaces. First remove the upper cowling by disengaging it from the lower cowling at the nose of the cowling, then lift up upper cowling segment. Disconnected controls of Carburettor heater (according of fitting 11-1) N.1 Remove the elastic tube (N.2), Remove holder of Oil cooler (N.3), release the oil cooler but do not disconnected oil hoses. Remove holder of water cooler (N.5,6)

Loosen screws of the lower cowling segment (N.8) and remove to the front. Disconnected during removal. Disconnect electrical wiring to landing light in lower cowling (if installed N.7).

If you want do installation cowlings – continue reverse direction.

Figure 10-1 /10-3

1. Intercooler
2. Expanse bottle for coolant
3. Airbox cap
4. Oil filter
5. Oil container

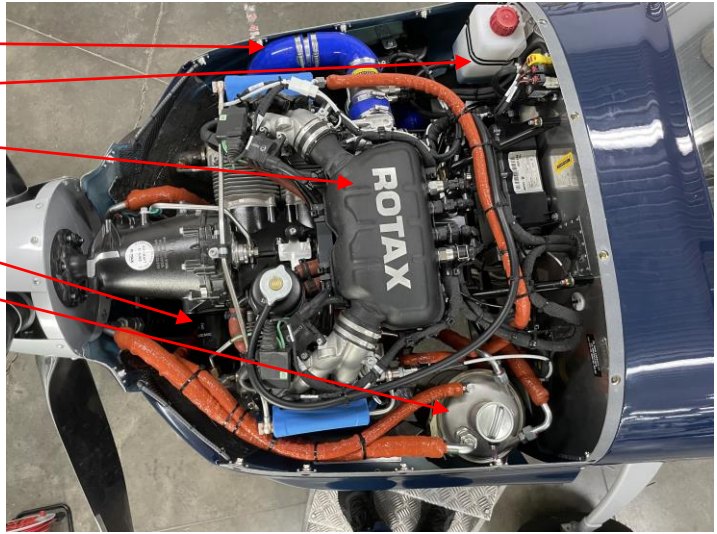

6. Engine mount
7. Oil cooler
8. Clip for elastic air tube
9. Air intake & Air filter
10. TBO

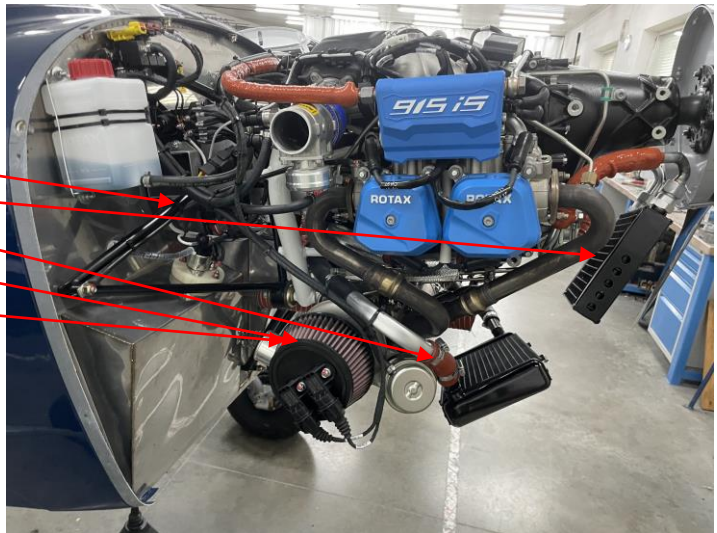

11. Socket head screws M8x80/10.9
12. Rubber chock mount pads
13. Collar bush
14. Shaped washer
15. Shelf-locking nut M8

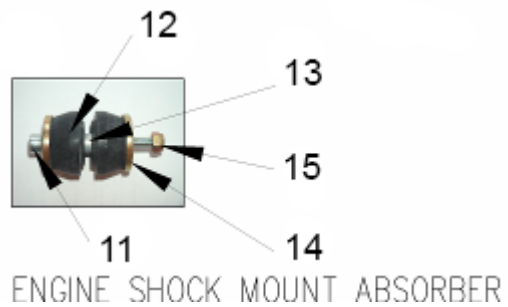

10.3 Cleaning and Inspection

Wipe the inner surfaces of the cowling segments with a cloth saturated with cleaning solvent. If the inside surface of the cowling is coated heavily with oil and dirt, allow solvent to soak until foreign material can be removed. Wash painted surfaces of cowling with a solution of mild soap and water and rinse thoroughly. After washing, a coat of wax applied to painted surface is recommended to prolong paint life. After cleaning, inspect cowling for cracks. Repair all defects to prevent spread of damage.

10.4 Repair

- 11.4.1 Required Tools: As required
 11.4.2 Parts required: Epoxy Resin, carbon fibre tape, roving, fabrics.
 11.4.3 Level of Maintenance: **Heavy**
 11.4.4 Certification required: **A&P Mechanic or Repairman Maintenance**

If cowling skins are extensively damaged, new complete sections of the cowling should be installed. If cracks are detected in the carbon fibre cowl segments, they may be repaired using L285 Epoxy Resin or similar (R&G L20), reinforcing with suitable carbon fibre fabrics. Follow the instructions on the container for a successful completion of the repair.

10.5 Engine

The ROTAX 915 Series engines are 4-stroke, 4 cylinder horizontally opposed, featuring one central camshaft with push rods and OHV (overhead valves). Cylinder heads are liquid cooled. Lubrication system is a dry sump forced type. Prop drive is via reduction gear with integrated shock absorber and overload clutch. Specific engine data are given in figure 11-2.

10.6 Engine Data

Figure 10-2

Engine manufacturer	ROTAX GmbH., Austria
Engine model	ROTAX 915 iS2 SPORT /141hp
Max. power	- take-off 104 kW / 141 HP
	- continuous 99 kW / 135 HP
Max. engine speed (MSL)	- take-off 5800 r.p.m. (max. 5 min)
	- continuous 5500 r.p.m.
Max. cooling liquid temperature	120,0 °C
Max. oil temperature	130,0 °C
Oil pressure	- minimum 0,8 bar
	- maximum 7,0 bar

Oil consumption	max. 0.06 l/h
Fuel pressure - minimum	2,5 bar
- maximum	3,5 bar
Consumption at starting	27,16 l/h
Consumtion at 75% of power rating	23 l/h
Specific consumption	280 – 310 g/(kW·h)
Propeller gearbox reduction ration	2.43 : 1

10.7 Trouble Shooting

Refer to Rotax 912/912S Maintenance Manual, latest issue. This table should be understand as a general guide to locate engine failures.

Trouble	Probable Cause	Remedy
Engine will not start.	Fuel tank empty.	Fill with proper grade of gasoline.
	Improper use of starting procedure.	Review starting procedure.
	Fuel shut-off valve closed.	Turn shut-off valve ON.
	Tank screen, or fuel lines plugged.	Remove and clean thoroughly. Remove moisture.
	Engine flooded.	Refer to paragraph 10.50.
	Defective ignition system.	Refer to paragraph 10.32.
	Excessive induction air leaks.	Correct the cause of leaks.
	Defective magneto switch or grounded magneto leads.	Check continuity. Repair or replace switch or wiring.
	Defective carburettor.	Repair or replace carburettor.
	Spark plugs fouled or improperly gapped.	Remove and clean: Check gaps and insulators. Check cables to persistently fouled plugs. Replace defective plugs.
	Defective magnetos or ignition amplifiers.	Replace defective parts in accordance with Rotax maintenance manual.
	Spark plugs loose.	Tighten to specified torque.
Water in fuel system.	Drain fuel tank sump, fuel	

		lines and carburettors.
	Excessive starter slippage.	Replace starter motor.
Engine will not run at idling speed.	Idle speed incorrectly adjusted.	Refer to paragraph 10.27.
	Carburettor idling jet plugged.	Clean carburettor.
	Air leak in intake manifold.	Tighten loose connections or replace damaged parts.
	Spark plugs fouled by oil escaping past piston rings.	Top overhaul engine.
Rough idling.	Idle speed incorrectly adjusted.	Refer to paragraph 10.27.
	Fouled spark plugs.	Remove and clean, adjust gaps. Test harness cables. If persistent perform top overhaul.
	Small air leak into induction system.	Tighten connections or replace damaged parts.
	Defective engine.	Check compression and listen for unusual engine noises. Engine repair is required.
Engine does not accelerate properly.	Cold engine.	Warm up longer.
	Restriction in carburettor air intake.	Remove restriction and clean filter.
	Restriction in carburettor jets, low float level.	Clean and repair carburettor.
	Incorrect carburettor synchronizing.	Synchronize carburettors in accordance to Rotax maintenance manual.
	Incorrect idle setting.	Refer to paragraph 10.27.
Engine does not shut off with ignition key in off position.	Broken wiring or defective magneto switch.	Repair wiring or replace magneto switch.
Engine runs rough at high speed.	Loose mounting bolts or rubber pads defective.	Tighten bolts or replace mounting pads.
	Propeller out of balance.	Remove and balance.
	Spark plug gap too large or insulator damaged.	Replace damaged parts.
	Ignition cable insulation damaged.	Test for leakage at high voltage and replace damaged ignition lead.
	Float chamber bleed hoses disconnected or broken.	Connect or replace bleed hoses.

Sluggish operation and low power.	Throttle not opening completely.	Rig per paragraph 10.37.
	Spark plugs fouled or improperly gapped.	Remove, clean and regap or install new plugs.
	Incorrect carburettor synchronizing.	Synchronize carburettors in accordance to Rotax maintenance manual.
	Incorrect carburettor mixture setting.	Adjust carburettors in accordance with Rotax maintenance manual.
High cylinder head temperature.	Low grade fuel.	Drain and fill with correct grade of fuel. Refer to Section 2.
	Excessive carbon deposits in cylinder head and on pistons.	Install new cylinders and piston rings or new engine.
	Low water level in cooling system.	Refill with suitable coolant and check for leaks.
	Dirt between cylinder fins.	Clean thoroughly.
High oil temperature.	Low oil supply.	Replenish.
	Oil viscosity too high.	Refer to Section 2 for seasonal grades.
	Oil regulator flap closed.	Set oil regulator flap to open position.
	Prolonged high speed operation on ground.	Hold ground running above 2500 rpm to a minimum.
Low oil pressure.	Low oil supply.	Replenish.
	Oil viscosity too low.	Drain and refill with correct seasonal grade. Refer to Section 2.
	Foam in oil due to emulsification of alkaline solids.	Drain and refill with fresh oil. Refer to Section 2 for seasonal grade.
	Defective pressure sensor.	Replace pressure sensor.
	Oil pump defective.	Remove and inspect. Examine engine. Metal particles from damaged pump may have entered engine oil passages.
	Oil pressure line broken, disconnected or pinched.	Inspect, replace or connect line.
	Internal leak, burned bearings, or damaged gasket.	Major overhaul.
Oil leak at propeller shaft.	Damaged propeller driveshaft seal.	Replace in accordance with Rotax maintenance

		manual.
Low compression.	Cylinder wall-coating worn.	Replace cylinder and rings.
	Intake valves guides worn.	Top overhaul.
	Valves seats and faces worn.	Top overhaul.
	Piston rings excessively worn.	Top overhaul.
	Valves sticking in guides.	Top overhaul.

10.8 Removal

10.8.1 Required Tools: Screwdriver, Phillips head screwdriver, edge cutter, gripper, 4-10 mm Allen wrench, 8-17 mm wrench.

10.8.2 Parts required: Insulating tape

10.8.3 Level of Maintenance: **Heavy**

10.8.4 Certification required: **A&P Mechanic or Repairman Maintenance**

If the engine is to be placed in storage or returned to the manufacturer for overhaul, proper preparatory steps should be taken prior to beginning the removal procedure. Refer to Temporary Storage in Section 2 for preparation of the engine for storage. The following engine removal procedure is based upon the engine being removed from the aircraft with the engine mount attached to the engine and all engine hose and lines being disconnected at the firewall. The reason for engine removal will determine where components are to be disconnected.

Note	Tag each item disconnected to aid in identifying wires, hoses, lines and control cables when engine is being installed. Protect openings, exposed as a result of removing or disconnecting units, against entry of foreign material by installing covers or sealing with tape.
-------------	--

- a. Place all cabin switches and fuel valves in the OFF position.
- b. Remove engine cowlings and open area behind Board panel. (See paragraph 10.2.)
- c. Remove Site and open battery circuit by disconnecting battery cable(s) at the battery. Insulate cable terminal(s) as a safety precaution.
- d. Disconnect all wiring at the terminals on the firewall (located in the right-hand side of the firewall).
- e. Disconnect wiring at voltage regulator terminal (located on lower right-hand side of the firewall) and remove cable ties and clamps as required.
- f. Disconnect ground wiring from right side of firewall.
- g. Drain oil from engine Remove propeller and spinner.
- h. Drain water from the engine cooling system by disconnecting one water radiator hose and opening the expansion tank cap.
- i. Disconnect hose connection to overflow bottle at upper right side of the firewall.

Note	During the following procedures, remove any clamps or cable ties which secure controls, wires, hose, or lines to the engine, engine mount, or attached brackets, so that they will not interfere with removal of the engine. Omit any of the items which are not present on a particular engine installation.
-------------	---

- k. Disconnect throttle and choke control at carburettor and oil-temperature control. Pull these controls free of engine and engine mount, using care not to damage them by bending too sharply.

WARNING	Residual fuel and oil draining from disconnected lines and hose is a fire hazard. Use care to prevent accumulation of such fuel and oil when lines or hose are disconnected.
----------------	--

- l. Disconnect oil hoses from oil tank (located on the right-hand side of the firewall).
- m. Disconnect fuel-, fuel-return- and fuel pressure (if installed) hose from firewall.
- n. Disconnect stopper and shock absorber of nose leg from engine mount

Caution	Attach a tail stand to the tail before removing the engine. The loss of engine weight will allow the tail to drop. Do not raise engine higher than necessary when removing mount-to-firewall bolts. Raising the engine too high places a strain on the attach bolts and hinders their removal.
----------------	--

- o. Attach a hoist to the inlet manifolds on top of the engine and take up engine weight on hoist.
- p. Remove bolts attaching mount-to-firewall. Note direction of bolt installation and position and numbers of washers. Balance the engine by hand as the last of the bolts are removed.

Caution	Hoist engine slowly and ascertain that all items attaching engine and accessories to airframe are disconnected.
----------------	---

- q. Disengage exhaust retaining springs and remove exhaust system.
- r. Remove exhaust down pipes from cylinder head (mark each down pipe location for reinstallation).
- s. Unscrew engine-to-mount screws and remove engine mount.
- t. Carefully guide disconnected components out of engine assembly.

10.9 Cleaning

The engine may be cleaned with a suitable solvent, then dried thoroughly.

Caution	Particular care should be given to electrical equipment before cleaning. Solvent should not be allowed to enter magnetos, starter, alternator and the like. Hence, protect these components before saturating the engine with solvent. Cover any fuel, oil and air openings on the engine and accessories before washing the engine with solvent. Caustic cleaning solutions should be used cautiously and should always be properly neutralized after their use.
----------------	---

10.10 Accessories Removal

Removal of engine accessories for overhaul or for engine replacement involves stripping the engine of parts, accessories, and components to reduce the engine assembly to the bare engine. During removal, carefully examine removed items and tag defective parts for repair or replacement by a new part.

Note	Items easily confused with similar items should be tagged to provide a means of identification when being installed on a new engine. All openings exposed by the removal of an item should be closed by installing a suitable cover or cap over the opening. This will prevent entry of foreign particles. If suitable covers are not available, tape may be used to cover the opening.
-------------	---

10.11 Inspection

For specific items to be inspected refer to engine manufacturer's manual.

- a. Visually inspect the engine for loose nuts, bolts, cracks and fin damage.
- b. Inspect brackets for cracks, deterioration and breakage.
- c. Inspect all hoses for internal swelling, chafing through protective plys, cuts, breaks, stiffness, damaged threads and loose connections. Excessive heat on hoses will cause them to become brittle and easily broken. Hoses and lines are most likely to crack or break near the end fittings and support points.
- d. Inspect for colour bleaching of the end fittings or severe discoloration of the hoses.

Note	Avoid excessive flexing and sharp bends when examining hoses for stiffness.
-------------	---

- e. All flexible fluid carrying hoses in the engine compartment should be replaced at engine overhaul or every five years, whichever occurs first.
- f. For major engine repairs, refer to the manufacturer's overhaul and repair manual.

10.12 Engine Build-Up

Engine build-up consists of installation of parts, accessories and components to the basic engine to build-up an engine unit ready for installation on the aircraft. All safety wire, lockwashers, palnuts, elastic stop nuts, gaskets and rubber connections should be new parts.

10.13 Installation (refer to figure 10-3.)

10.13.1 Required Tools: Refer to paragraph 10.8

10.13.2 Parts required: Various self-locking nuts, cable ties, hose clamps, safetying wire (1.0 mm).

10.13.3 Level of Maintenance: **Heavy**

10.13.4 Certification required: **A&P Mechanic / Repairman Maintenance**

Before installing the engine on the aircraft, install any items that were removed from the engine after it was removed from the aircraft.

Note	Remove all protective covers, plugs, caps and identification tags as each item is connected or installed.
-------------	---

- a. Hoist engine assembly at the inlet manifold on top of the engine.
- b. Install engine to the engine mount use screws M12 (refer to N.6 figure 10-3.)
- c. Place engine mount to the engine brackets and tighten engine-to-mount bolts to a torque value of 40 Nm/350 in.lb. Secure screws by wire, refer to figure 10-3 for installation details.
- d. Install exhaust down pipes and exhaust system, do not tighten retaining screws at that time.
- e. Move complete assembly to firewall and align screw and engine shock absorbers to the holes of the engine mount-firewall. (refer to N.7 figure 10-3)
- f. Install engine-to-firewall screws and tighten to a torque value of 24Nm/350 in.lb. Remove hoist and stand placed under the tail.

- g. Connect Air box and carburetors to the arm of engine mount and engine assembly
- h. Connect oil temperature control to oil regulator flap assembly and secure by cable tie to air intake hose (if fitted).
- i. Route throttle and mixture controls to the carburettor and connect as noted in step “k” of paragraph 10.8.
- j. Connect lines and hoses as follows:
 1. Fuel- and fuel-return hose at firewall.
 2. Fuel pressure hose at firewall (if fitted).
 3. Oil hoses to oil tank.
 4. Cooling fluid hose from overflow bottle to expansion tank.
 5. Cabin heat hose to heater shell on exhaust system.
 6. Install all clamps attaching lines and hoses to engine, engine mount, or attached brackets.
- k. Connect wires and cables as follows:
 1. Ground wiring to firewall.
 2. Wiring to voltage regulator at firewall.
 3. Engine wiring to terminal at Connector-Box on firewall.
- l. Install all clamps attaching wires and cables to engine, engine mount, or attached brackets.
- m. Install propeller and spinner (refer to Section 12).
- n. Make sure that routing of exhaust pipes does not interfere with surrounding components and tighten retaining screws on cylinder heads to a maximum torque value of 26 Nm/230 in.lb.
- o. Service engine with proper grade and quantity of engine oil. Refer to engine manufacturers manual or EuroFox Pilot Operating Handbook.
- p. Make sure all switches are in the OFF position, and connect battery cable(s) to battery.
- r. Rig throttle, choke and carburettor heat controls in accordance with paragraph 10.36 through 10.40.
- s. Check engine installation for security, correct routing of controls, lines, hoses and tightness of all components.
- t. Bleed engine oil system in accordance with engine manufacturer maintenance manual.
- u. Clean and install carburettor air filter. Be sure all hot and cold air ducts are installed and connected.



- v. Perform engine run-up and make final adjustments on engine controls.
- w. Install engine cowling.

10.14 Flexible Fluid Hoses

10.15 Leak Test

After each 100 hours of engine operation, all flexible fluid hoses in the engine compartment should be checked for leaks as follows:

- a. Examine the exterior of hoses for evidence of leakage or wetness.
- b. Hoses found leaking should be replaced.
- c. Refer to paragraph 10.11. for detailed inspection procedures for flexible hoses.

10.16 Replacement

- a. Hoses should not be twisted on installation. Pressure applied to a twisted hose may cause failure or loosening of the nut.
- b. Provide as large a bend radius as possible.
- c. Hoses should have a minimum of one-half inch clearance from other lines, ducts, hoses or surrounding objects or be butterfly clamped to them.
- d. Rubber hoses will take a permanent set during extended use in service.
- e. Straightening a hose with a bend having a permanent set will result in hose cracking. Care should be taken during removal so that hose is not bent excessively, and during reinstallation to assure hose is returned to its original position.

10.17 Static Run-Up Procedure

In a case of suspected low engine power, a static RPM run-up should be conducted as follows:

- a. Run-up engine, using take-off power, with the aircraft facing 90° right and then left to the wind direction.
- b. Record the RPM obtained in each run-up position.

Note	Daily changes in atmospheric pressure, temperature and humidity will have a slight effect on static run-up.
-------------	---

- c. Average the result of the RPM obtained. At all models it should be within 100 RPM of 5000 RPM.
- d. If the average results of the RPM obtained are lower than stated above, the following recommended checks may be performed to determine a possible deficiency:
 1. Check carburettor heat control for proper rigging. If partially open it would cause a slight power loss.
 2. Check choke control for proper rigging.
 3. Check spark plugs and ignition harness for settings and conditions.

4. Check both magnetos are working properly.
5. Check condition of induction air filter. Clean if necessary.
6. Perform an engine compression check. (Refer to engine Manufacturer's Manual.)

10.18 Engine Mount (refer to figure 10-2.)

The engine mount is composed of sections of tubing welded together and reinforced with welded gussets. The purpose of the engine mount, is to support the engine and attach the engine to the airframe. The engine is attached to the mount with Screws and mount is attached to the airframe through shock mount assemblies which absorb engine vibrations.

10.19 Removal and Installation

- | | |
|---------------------------------|---|
| 10.19.1 Required Tools: | 8 mm Allen wrench |
| 10.19.2 Parts required: | Loctite 243 |
| 10.19.3 Level of Maintenance: | Heavy |
| 10.19.4 Certification required: | A&P Mechanic / Repairman Maintenance |

Removal of the engine mount necessitates removal of the engine, followed by removal of the bolts attaching the engine-to-mount. The engine and engine mount may be removed from the aircraft and then engine removed from the mount. Refer to paragraph 10.13. for detailed information.

10.20 Repair

Perform engine mount repair as outlined in Section 18. The mount should be painted with heat-resistant grey enamel after welding or whenever original finish has been removed.

10.21 Shock-Mount Pads

The rubber shock-mounts are designed to reduce transmission of engine vibrations to the airframe. The rubber parts should be wiped with a clean dry cloth. Inspect rubber parts for swelling, cracking, or pronounced set of the part. Replace with new parts all parts that show evidence of wear or damage.

10.22 Engine Oil System

The Rotax 915 Series engine is provided with a dry sump forced lubrication system with a main oil pump with integrated pressure regulator and oil pressure sensor. The oil pump is driven by the camshaft. The oil pump sucks the motor oil from the oil tank via the oil cooler and forces it through the oil filter to the points of lubrication in the engine. The surplus oil emerging from the points of lubrication accumulates on the bottom of crankcase and is forced back to the oil tank by the blow-by gases. A vent line on the oil tank provides venting of the circuit. An oil temperature sensor for reading of the oil inlet temperature is located on the oil pump housing. Refer also to the engine Operators Manual for detailed information.

10.23 Trouble Shooting

The following listing should be understood as quick reference guide to locate particular trouble which may occur to the engine oil system. For detailed information refer to the engine manufacturers Maintenance Manual.

Trouble	Probable Cause	Remedy
No oil pressure.	No oil in system.	Fill system with proper grade and quantity of oil. Refer to Section 1.
	Oil pressure line broken, disconnected or pinched.	Replace or connect.
	Oil pressure line broken, disconnected or pinched.	Replace or connect.
	Defective oil pressure sensor.	Replace oil pressure sensor.
	Wiring of oil pressure sensor broken or disconnected.	Connect or repair wiring.
	Oil pump defective.	Remove and inspect in accordance with the Rotax Maintenance Manual.
Low oil pressure.	Defective oil pressure sensor.	Replace oil pressure sensor.
	Defective oil pressure gauge.	Replace or repair Rotax Flydat.
	Low viscosity oil.	Drain oil and refill with proper grade and quantity of oil.
	Oil pump defective.	Remove and inspect in accordance with the Rotax Maintenance Manual.
	Oil pump suction tube screen plugged or internal oil leak.	Engine overhaul required.
	Secondary result of high oil temperature.	Observe oil temperature gauge for high indication. Determine and correct reason for high oil temperature.
	Oil system not bled correctly.	Bleed oil system in accordance with Rotax Maintenance Manual.
	Oil filter element not tight.	Tighten oil filter in accordance with Rotax Operators Manual.

High oil pressure.	Defective oil pressure sensor.	Replace oil pressure sensor.
	Defective oil pressure gauge.	Replace or repair Rotax Flydat.
	High viscosity oil.	Drain oil and refill with proper grade and quantity of oil
Low oil temperature.	Defective oil temperature sensor.	Replace oil temperature sensor.
	Defective oil temperature gauge.	Replace or Repair Rotax Flydat.
High oil temperature.	Excessive rate of climb.	Avoid low airspeed.
	Closed oil cooler flap.	Move flap to "open" position.
	Defective oil temperature sensor.	Replace oil temperature sensor.
	Defective oil temperature gauge.	Replace or Repair Rotax Flydat.
	Low oil supply.	Refer to Rotax Maintenance Manual.
	Oil viscosity too high. Dirty oil.	Drain oil and refill with proper grade and quantity of oil.
	Prolonged high speed operation on the ground.	Hold ground running above 2500 rpm to a minimum.

10.24 Filter Element Removal and Installation

- 10.24.1 Required Tools: Head screwdriver, edge cutter.
 10.24.2 Parts required: New filter element, cable ties.
 10.24.3 Level of Maintenance: **Line**
 10.24.4 Certification required: **Repairman Maintenance or Owner**

- a. Remove engine cowling as necessary for access.
- b. Unscrew oil filter from oil pump at the front of the engine. Oil will drain from oil filter as it is removed from engine.
- c. Inspect engine gasket seat for gouges, deep scratches, wrench marks, and mutilation.
- d. Lubricate gasket of the new filter and screw to engine, do not over tighten filter element.
- e. Install parts removed for access, and service the engine with proper grade and quantity of engine oil.
- f. Start engine and check for proper oil pressure. Check for oil leaks after warming up engine.

- g. Again check for oil leakage after engine has been run at a high power setting (preferably a flight around the field).

Note	Before discarding removed filter element, cut the outer skin and check inside for evidence of internal engine damage such as chips or particles from bearings. In new or newly overhauled engines, some small particles or metallic shavings might be found, these are generally of no consequence and should not be confused with particles produced by impacting, abrasion, or pressure. Evidence of internal engine damage found in the oil filter element justifies further examination to determine the cause.
-------------	---

Note	When installing a new filter element, it is important that the gasket is clean, lubricated and positioned properly, and that the correct amount of torque is applied to the filter. If the filter is under-torque, oil leakage will occur. If the filter is over-torque, the filter can possibly be deformed, again causing oil leakage. Lubricate rubber gasket of new filter element with clean engine oil. A dry gasket can cause a false torque value, again resulting in oil leakage.
-------------	--

10.25 Engine Fuel System

The engine is equipped with two carburetors mounted at the upper side of the engine. The carburetors are of the constant velocity type, installed to each manifold of the engine. For overhaul and repair of the carburetors refer to the manufacturer's maintenance and repair manual.

10.26 Carburettor Removal and Installation

- 10.26.1 Required Tools: Head screwdriver, 8/10/13 mm wrench, 13 mm socket wrench.
- 10.26.2 Parts required: Self-locking nut (M6), cable ties, lock screw.
- 10.26.3 Level of Maintenance: **Line**
- 10.26.4 Certification required: **A&P Mechanic or Repairman Maintenance**

- a. Place fuel shut-off valve in the OFF position.
- b. Remove engine cowling.
- c. Disconnect flexible hose from intake heater carburettor.
- d. Remove manifold temperature sensor from top of the air box if it is installed, remove air box
- e. Disconnect throttle and choke controls from arms on carburettor. Note EXACT position and size of bushings for reference on reinstallation.
- f. Disconnect and plug the fuel and air lines at carburettors.
- g. Loosen bolts and clamps attaching carburettor to intake manifold. Remove carburettors.
- h. Reverse the preceding steps for reinstallation.
- i. Rig controls in accordance with applicable paragraph in this Section.
- j. Check carburettor throttle arm to idle stop arm attachment for security and proper safteying at each normal engine inspection.

10.27 Idle Speed Adjustment

- 10.27.1 Required Tools: Screwdriver
 10.27.2 Parts required: Lock screw
 10.27.3 Level of Maintenance: **Line**
 10.27.4 Certification required: **Repairman Maintenance or Owner**

Note	Idle speed adjustment should be accomplished after the engine has been warmed up. Engine idle speed may vary among different engines. An engine should idle smoothly, without excessive vibration, and the idle speed should be high enough to maintain idling oil pressure and to preclude any possibility of engine stoppage in flight when the throttle is closed.
-------------	---

- a. Set the throttle stop screws to obtain between 1700 and 1800 rpm, with throttle control pulled full out against idle stop.
- b. Check that both idle stop screws contact its idle stop brackets at the same time and readjust if necessary.
- c. Apply laquer to each idle stop screw to secure proper safteying.

10.29 Induction Air System

Ram air to the engine enters the induction air box through an opening in the forward part of the upper engine cowling nose. The air is filtered through a filter which is located at the inlet of the air box. From the induction air box the filtered air is directed to the inlet of each carburettor, mounted on the upper side of the engine, and through the carburettor, where fuel is mixed with the air, to the intake manifold. From the intake manifold, the fuel-air mixture is distributed to each cylinder by separate intake pipes. The intake pipes are attached to the cylinders with a two bolt flange which is sealed with a gasket. A distributor box on the air intake contains a valve, operated by a carb heat control in the cabin, which permits air from an exhaust



heated source to be selected in the event carburettor icing or filter icing should be encountered.

10.30 Removal and Installation

Remove and install air box system as outlined in paragraph 10.26

10.34 Spark Plugs

Two spark plugs are installed in each cylinder. The spark plugs are shielded to prevent spark plug noise in the radio and the spark plugs have an internal resistor to provide longer terminal life. Spark plug life will vary with operating conditions. A spark plug that is kept clean and properly gapped will give better and longer service than one that is allowed to collect lead deposits and is improperly gapped. The correct spark plug and gap setting is given in paragraph 10.1.

Note	At each 100-hour inspection, remove, clean, inspect, and regap all spark plugs. Install lower spark plugs in upper portion of cylinder and install upper spark plugs in lower portion of cylinder at each 100-hour inspection. Since deterioration of lower spark plugs is usually more rapid than that of the upper spark plugs, rotating them helps prolong spark plug life.
-------------	--

10.35 Engine Controls

Engine controls of the push-pull type include the throttle, choke and carburettor heat controls. The engine controls are equipped with position-locking devices which prevent vibration-induced “creeping” of the controls.

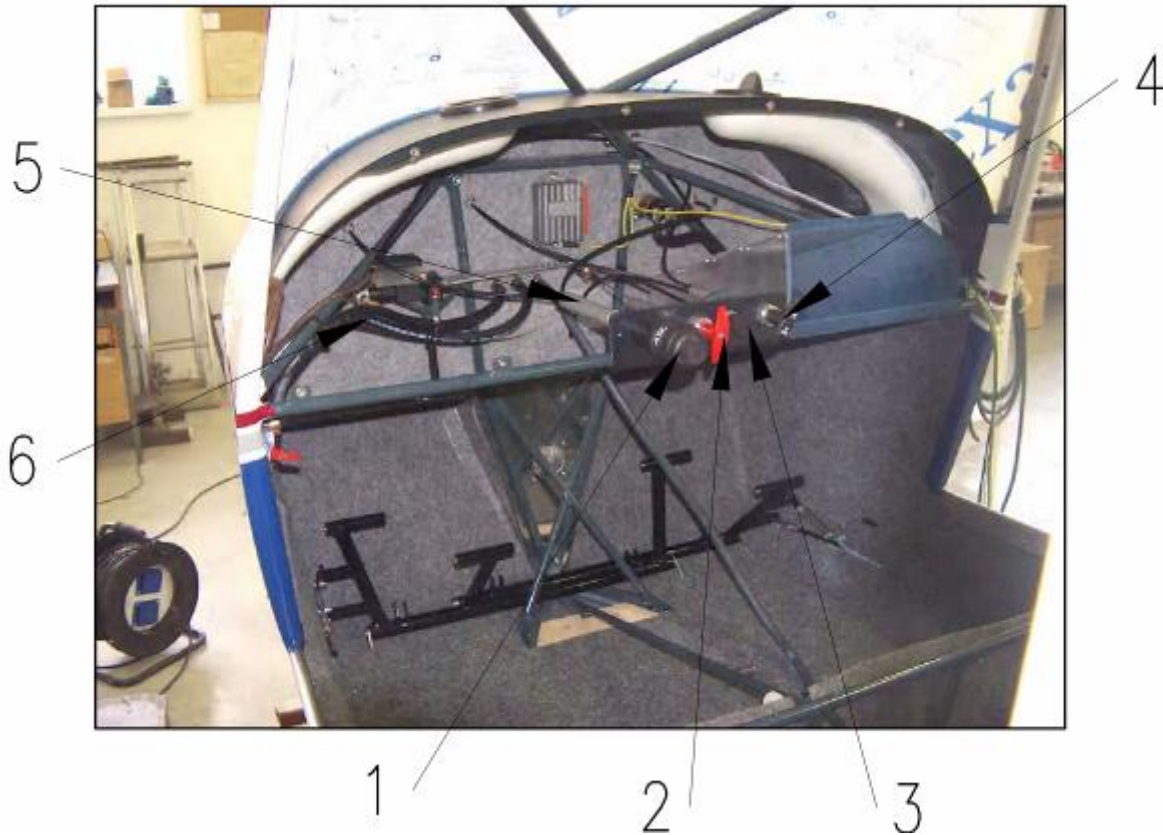
Figure10-4

1. Throttle knob
2. Brake and Parking brake (Depend of version)
3. Carburettor Heater lever
4. Chock control lever (N/A – for Rotax 912 iS)
5. Mixer for control wire for thtottle flap
6. Fuel hoses

10.36 Rigging

When adjusting any engine control, it is important to check that the control slides smoothly throughout its full range of travel, that it locks securely if equipped with a locking device, and the arm or lever which it operates moves through its full arc of travel.

Caution

Whenever engine controls are being disconnected, pay particular attention to the exact position, size, and number of attaching washers, spacers or bushings. Be sure to install attaching parts as noted when connecting controls.

10.37 Throttle Control

- 10.37.1 Required Tools: 8 & 10 mm open-end wrench
10.37.2 Parts required: Lock screw
10.37.3 Level of Maintenance: **Line**
10.37.4 Certification required: **A&P Mechanic or Repairman Maintenance**

Note	Before rigging throttle control ensure that control cable are in proper condition.
-------------	--

- a. Push throttle to full throttle position and check that both actuator arms on carburettor achieve maximum position.
- b. Adjust locknut at carburettor end of control as required to achieve the maximum travel of each actuator lever.
- c. Pull throttle control to idle position.
- d. Check that both idle stop screws contact its idle lock and adjust if required. e. Check idle speed in accordance with paragraph 10.27.
- f. Check carburettor synchronizing in accordance with paragraph 10.28.
- g. Tighten rod end locknuts at carburettor end of control. Be sure to maintain sufficient thread engagement between rod end and control.

Note	Refer to the inspection chart in Section 2 for inspection and / or replacement interval for the throttle control.
-------------	---

Note	Before rigging carburetors heat control ensure that control cable are in proper condition.
-------------	--

- a. Push carburettor heat control to off-position.
- b. Check cable tension for proper setting on end of control, adjust if required (carburettor heat arm must touch to its locks in the off position).
- c. Pull carburettor heat control to on-position.
- d. Check that both arm on carburet heat achieve their maximum travel. If required readjust controls at the locknut on carburettor heat arm.

10.40 Starting System

The automatically engaged starting system employs an electric starter motor mounted at the rear of the engine housing. A starter solenoid is activated by the unlock key and pushing knob on the instrument panel. For activated of ignition is on the instrument panel about knobs two switchers When the solenoid is activated, its contacts close and electrical current energizes the starter motor.

10.41 Trouble Shooting

Trouble	Probable Cause	Remedy
Starter will not operate.	Defective master switch or circuit.	Install new switch or wires.
	Defective starter switch or switch circuit.	Install new switch or wires.
	Defective starter motor.	Remove, repair or install new starter motor.
Starter motor runs, but does not turn crankshaft.	Starter motor shaft broken.	Install a new starter motor.
Starter motor drags.	Low battery.	Charge or install a new battery.
	Starter switch or relay contacts burned or dirty.	Install serviceable unit.
	Defective starter motor power cable.	Install new cable.
	Loose or dirty connections.	Remove, clean and tighten all terminal connections.
	Defective starter motor.	Repair or install a new starter motor.

10.42 Removal and Installation

- 10.42.1 Required Tools: Screwdriver, 10 mm wrench.
10.42.2 Parts required: Self-locking nut (M6), insulating tape.
10.42.3 Level of Maintenance: **Line**
10.42.4 Certification required: **A&P Mechanic or Repairman Maintenance**

- a. Remove cowling as required for access.
- b. Disconnect starter power cable at starter. Insulate terminal on power cable to prevent accidental shorting.
- c. Remove carburettor on the right side of engine and remove necessary equipments in this area important for Remove bolts, unattached starter to crankcase.
- d. Withdraw starter motor from engine housing.
- e. Reverse preceding steps for reinstallation.
- f. Torque starter motor retaining bolts to a torque value in accordance to the engine manufacturer's maintenance manual.

10.43 Exhaust System

The exhaust system consists of a muffler with an exhaust pipe from each cylinder to the muffler. The muffler assemblies are enclosed in shrouds which captures ram air to be heated by the exhaust gases in the muffler. This heated air is used to heat the aircraft cabin. A tail pipe from the muffler routes exhaust gases overboard through the lower cowling. The complete exhaust system is manufactured from stainless steel.

10-44. Removal

- 10.44.1 Required Tools: Screwdriver, gripper, 12 & 13 mm wrench
10.44.2 Parts required: Heat resistant silicone, 8 x self-locking copper nut (M8).
10.44.3 Level of Maintenance: **Line**
10.44.4 Certification required: **A&P Mechanic or Repairman Maintenance**

- a. Remove engine cowling as required for access.
- b. Disconnect flexible hose from heater shell on muffler assembly.
- c. Remove nuts securing the down pipes to the cylinders.
- d. Disengage retaining springs from muffler and remove muffler.
- e. Carefully remove down pipes and unscrew exhaust probes from each of the downpipes.

10.45 Inspection

Inspection of the exhaust system must be very thorough because the cabin heating system uses air heated by the heat exchangers of the exhaust system. Since exhaust system of this type are subject to burning, cracking, and general deterioration from alternate thermal stresses and vibration, inspection is very important and should be accomplished every 100-hour of operation. In addition, an inspection of the exhaust system shall be performed anytime exhaust fumes are detected in the cabin area.

- a. Remove engine cowling, and remove muffler and heater shell so that ALL surfaces of the exhaust system can be visually inspected. Especially check areas adjacent to welds. Look for exhaust gas deposits in surrounding areas, indicating that exhaust gas is escaping through a crack or hole.
- b. For a more thorough inspection, or if fumes have been detected in the cabin, the following inspection is recommended.
 1. Remove exhaust pipe and mufflers.
 2. Use rubber expansion plugs to seal openings.
 3. Using a manometer or gauge, apply approximately 1-1/2 psi air pressure while the mufflers and each exhaust pipe is submerged in water. All leaks will appear as bubbles and can be readily detected.
- c. It is recommended that any exhaust pipe or muffler found defective be replaced with a new part before the next flight.

10.46 Extreme Weather Maintenance

10.47 Cold Weather

Generally, an engine service should be carried out before the start of the cold season. For selection of coolant and mixing ratio refer to the Rotax operator manual. For selection of oil refer to Section 1.

Start engine with throttle closed and choke activated (open throttle renders starting carb ineffective). As performance of electric starter is greatly reduced when cold, limit starting to periods not longer than 10 seconds and with a well charged battery (adding a second battery will not improve cold starts).

10.48 Hot Weather

Engine miss-starts characterized by weak, intermittent explosions followed by puffs of black smoke from the exhaust are caused by flooding. This situation is more apt to develop in hot weather or when the engine is hot. If it occurs, repeat the starting routine with the throttle full OPEN. As the engine fires, decrease the throttle setting to desired idling speed.

Caution

Never operate the starting motor more than 10 seconds at a time. Allow starter motor to cool between cranking periods to avoid shortening the life of the starter.

10.49 Dusty Conditions

Dust inducted into the intake system of the engine is probably the greatest single cause of early engine wear. When operating under high dust conditions, the induction air filter should be serviced daily as outlined in paragraph 2.16.

10.50 Seacoast and Humid Areas

In salt water areas, special care should be taken to keep the engine and accessories clean to prevent oxidation. In humid areas, fuel and oil should be checked frequently and drained of condensed moisture.

Section 11

Fuel system

Table of contents		Page
11.1	Fuel system.....	11-0
11.2	Description.....	11-0
11.3	Precautions.....	11-1
11.4	Trouble shooting.....	11-1
11.5	Fuel tank.....	11-2
11.6	Description.....	11-2
11.7	Removal and installation.....	11-2
11.8	Fuel filter.....	11-4
11.9	Removal and installation.....	11-4
11.10	Fuel vent.....	11-4
11.11	Checking.....	11-4
11.12	Fuel shut-off valve.....	11-4
11.13	Removal and installation.....	11-4
11.14	Fuel drain valve.....	11-5
11.15	Removal and installation.....	11-5
11.16	Fuel distributor system.....	11-6
11.17	Removal and installation.....	11-6
11.18	Inspection.....	11-7

11.1 Fuel system

11.2 Description

The fuel is gravity fed from the right-hand or left-hand wing tank into the link tank depending which wing tank fuel cock is open. The fuel is then further directed from the link tank via the main fuel cock and fuel filter into the mechanical fuel pump on the engine which delivers the fuel to the carburettors. The amount of fuel in the tank is indicated by a visual sight gauge which is a part of each tank. Minimum fuel quantity in the link tank is visually indicated by the lighting of a warning light on the instrument panel. The remaining fuel, i.e. 1.05 gal is sufficient enough for 15 minutes of flight. The drain cock outlet is behind the left seat on the outside bottom side of the fuselage; to drain off water and dirt, the drain pipe is to be pressed into fuselage and subsequently a fuel sample can be taken.

11.3 Precautions

Note	There are certain general precautions and rules concerning the fuel system which should be observed when performing the operations and procedures in this section. These are as follows.
-------------	--

1. During all fuelling, defuelling, tank purging, and tank repairing or disassembly, ground the aircraft to a suitable ground stake. Use the engine or negative battery terminal for grounding.
2. Residual fuel draining from lines and hose constitutes a fire hazard. Use caution to prevent the spillage of fuel when lines or hoses are disconnected.
3. Cap any open fuel lines and cover connection points to prevent thread damage and the entrance of any foreign matter.

11.4 Trouble shooting

Trouble	Probable Cause	Remedy
No fuel to carburettor.	Fuel shut-off valve not turned on.	Turn valve on.
	Fuel tanks empty.	Service with proper grade and amount of fuel.
	Fuel line disconnected or broken.	Connect or repair fuel lines.
	Fuel tank outlet screen plugged.	Drain fuel, remove outlet screen and clean thoroughly.
	Fuel filter plugged.	Replace fuel filter.
	Defective shut-off valve.	Replace shut-off valve.
	Fuel line plugged.	Clean out or replace fuel line.
	Defective mechanical fuel pump.	Replace fuel pump.
Fuel starvation after starting.	Partial fuel flow from the preceding causes.	Use the preceding remedies.
	Plugged fuel vent.	See paragraph 11.14.
	Water in fuel.	Drain fuel tank sumps, fuel lines and carburettors.
No fuel quantity indication.	Fuel tanks empty.	Service with proper grade and amount of fuel.
	Blown fuse / circuit breaker.	Replace fuse / reset circuit breaker.

	Loose connection or open circuit.	Tighten connections, repair or replace wiring.
	Defective fuel quantity indicator or transmitter.	Refer to Section 15.
Fuel overflow from carburettor.	Binding float valve or dirt in floater chamber.	Clean and repair carburettor.
	Plugged fuel distributor or fuel return line jet.	Clean fuel distributor thoroughly.
Pressurized fuel tank.	Plugged fuel vent.	See paragraph 11.14.

11.5 Fuel tank

11.6 Description

The fuel system includes two aluminium wing tanks of 10.6 gal fuel capacity each, a special plastic (manufactured for contact with gas) link tank of 1.32 gal capacity, a drain cock, three fuel cocks, a fuel filter, an engine fuel pump and a connecting line.

As the fuel tanks are glue to the wing frame, it is not possible to remove them once installed.

11.7 Removal and installation link tank

12.7.1 Required Tools:	Set of wrench, screwdriver, pliers.
12.7.2 Parts required:	Fuel resistant sealant fluid.
12.7.3 Level of Maintenance:	Heavy
12.7.4 Certification required:	A&P Mechanic or Repairman Maintenance

- a. Push up sump drain valve, to drain all fuel from the tanks. (Observe precautions outlined in paragraph 11.3.)
- b. Remove seats as outlined in Section 3.
- c. Disconnect fuel hose for right and left wing-tank
- d. Disconnect fuel hose connected to the fuel pump
- e. Remove the two metal strips securing the link tank
- i. To install tank, reverse the preceding steps. Be sure grounding is secure in accordance with paragraph 11.3.

Note	Apply appropriate liquid sealant to the threads of drain valve and fuel line connector while reassembling the system.
-------------	---

Figure 11-1

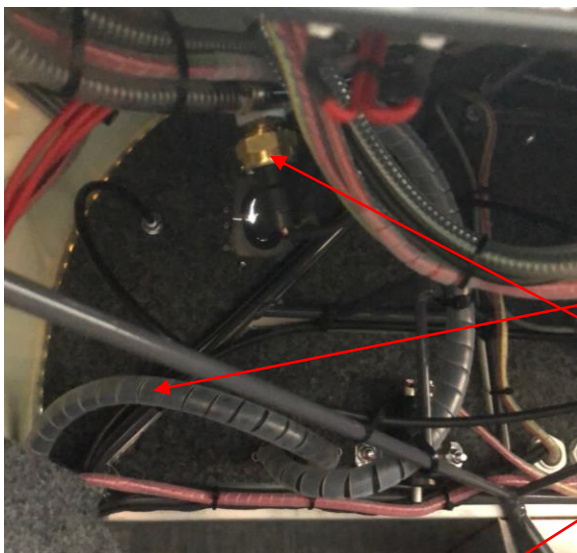

1. Fuel hose for left wing-tank
2. Fuel hose from right wing-tank
3. Header tank vents
4. Fuel pumps box
5. Fuel Filter
6. Header tank
7. Sensor of last 4 liters fuel
8. Fuel hose connected
9. Fuel return to the tank
10. Hose to fuel pressure gauge
11. Hose to intake to injection unit
12. Hose back track line from injection

11.8 Fuel filter

An additional screen type fuel filter is attached to the fuel hose at the inlet of the fuel pump. Refer to Section 2 for replacement intervals of the fuel filter.

11.9 Removal and installation

11.9.1 Required Tools:	screwdriver, clamp tongs.
11.9.2 Parts required:	Hose clamps, fuel filter.
11.9.3 Level of Maintenance:	Light
11.9.4 Certification required:	Repairman Maintenance or Owner

- a. Unplug fuel hoses connected to the filter by loosening the two hose clamps.
- b. Disconnect the fuel hoses from the filter.
- c. Replace filter.
- d. To install filter, reverse the preceding steps. Be sure grounding is secure in accordance with paragraph 11.3.

11.10 Fuel vent (N.3, Figure 11-1)

A vent line is installed to each tank cap and extends overboard in a vertical direction from each wing tank.

11.11 Checking

Dirt may cause the fuel vent to become blocked, with possible fuel starvation of the engine or collapse of the fuel tank. The following procedure may be used to check the vent line.

- a. Attach a rubber tube to the end of the vent line above the Wing Tank.
- b. Blow gently into tube to slightly pressurize the tank. If air can be blown into tank, vent line is open.
- c. After tank is slightly pressurized, insert end of rubber tube into a container of water and watch for a continuous stream of bubbles, which indicates the vent line is clear from obstacles.

11.12 Fuel shut-off valve

There is a two-position ON-OFF fuel shut-off valve for each wing tank, located above the pilots head on either side of the cockpit (N.9 Figure 11-1) and a master on-off fuel valve is located below the instrument panel on the left hand side of the cabin. It is recommended that the valve be replaced and not repaired if damaged.

11.13 Removal and installation

11.13.1 Required Tools:	set of wrench, edge cutter, screwdriver.
11.13.2 Parts required:	Fuel line fittings, cable ties.
11.13.3 Level of Maintenance:	Heavy
11.13.4 Certification required:	A&P Mechanic or Repairman Maintenance

- a. Completely drain all fuel from tank and fuel lines (Observe the precautions in paragraph 11.3).
- b. Remove instrument panel
- c. Disconnect fuel line at the firewall and at the rear end hose connection.

Caution

For reconnection of fuel line to firewall a new fuel line fitting has to be used, to avoid leakage.

- d. Remove screws attaching shut-off valve.
- e. Withdraw shut-off valve assembly from the holder on the fuselage.
- f. Disconnect fuel lines from shut-off valve.
- g. Reverse the preceding steps for installation.

11.14 Fuel drain valve

A fuel drain valve is installed to the bottom of the link tank. Access is possible from beneath the fuselage adjacent to the main gear. To drain fuel, push the white plastic tube upwards.

11.15 Removal and installation

- 11.14.1 Required Tools: Set wrench, screwdriver.
11.14.2 Parts required: Fuel resistant sealant fluid.
11.14.3 Level of Maintenance: **Heavy**
11.14.4 Certification required: **A&P Mechanic or Repairman Maintenance**

- a. Push up sump drain valve , to drain fuel completely from the tank (Observe precautions outlined in paragraph 11.3).
- b. Remove the seats as outlined in Section 3.
- c. Remove the plastic link tank according 11.7
- d. Reverse the preceding steps for installation. Be sure grounding is secure in accordance with paragraph 11.3.

Note

Apply appropriate liquid sealant to the threads of the drain valve during reassembling.

11.16 Fuel distributor system (refer to Figure 11-2.)

A fuel distributor is installed to provide fuel for both carburetors. The fuel distributor is located on top of the engine. Pressurized fuel from the fuel pump is routed to both carburetors while surplus of fuel flows back to the fuel tank through a return hose. A 0.02 inch jet is provided to the return hose fitting to ensure the required fuel pressure. A fuel pressure gauge may be connected to check fuel pressure at the opposite side of the return hose connection.

Figure11-2

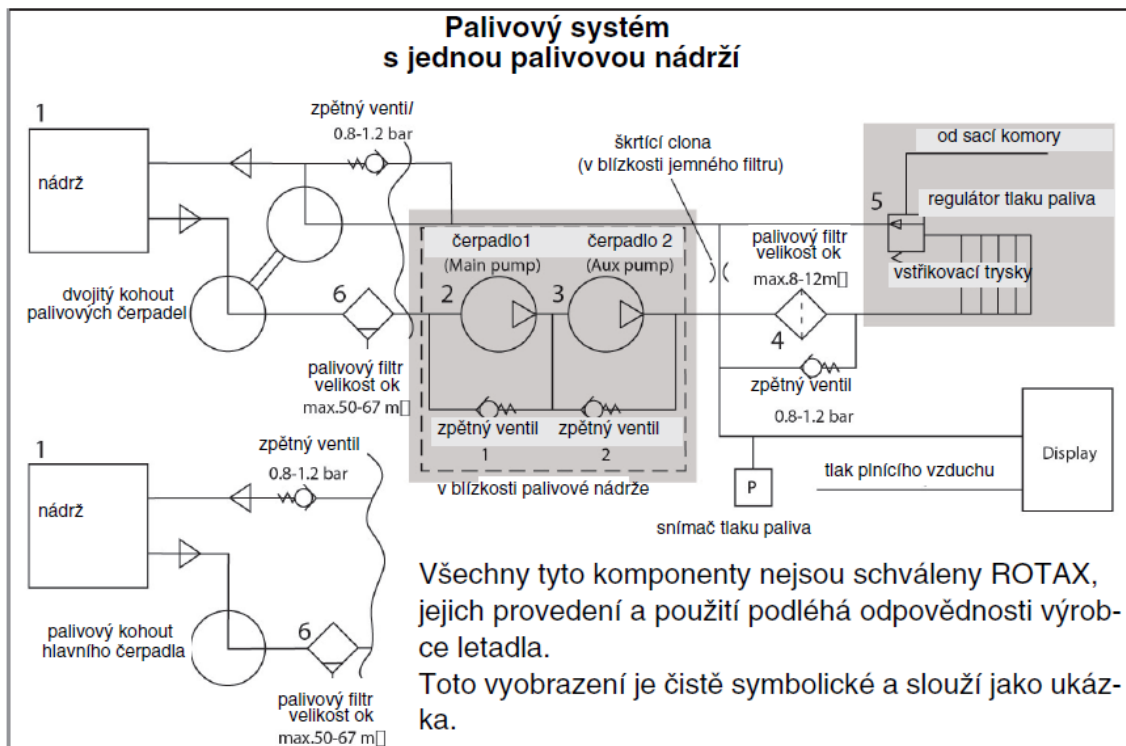

11.17 Removal and installation

- 11.17.1 Required Tools: Set of wrench, edgecutter, screwdriver.
- 11.17.2 Parts required: Lock screw, copper sealings, hose clamps.
- 11.17.3 Level of Maintenance: **Light**
- 11.17.4 Certification required: **Repairman Maintenance or Owner**
- Drain fuel from the fuel lines (Observe precautions outlined in paragraph 11.3.).
 - Disconnect hoses from the fuel distributor block.
 - Remove clamp securing distributor block to engine.
 - Disconnect hose fittings from the distributor.

Caution Remember position of return hose fitting for reinstallation.

- Reverse preceding steps for reinstallation (Observe precautions outlined in paragraph 11.3.).

Caution Always use new copper sealing for reinstallation of hose fittings and new hose clamps for hose connections.

11.18 Inspection

Inspect fuel distributor for clean condition, especially check jet drillings for the return hose and the fuel pressure gauge connection to be unplugged. Clean hose fittings thoroughly before reassembly. Check also the jet provided in the return hose fitting for clean and unblocked condition.

Section 12

Propeller

Table of contents	Page
12.1 Propeller.....	12-0
12.2 Repair.....	12-0
12.3 Removal.....	12-0
12.4 Installation.....	12-2

12.1 Propeller

A composite, fixed-pitch propeller, equipped with a spinner, is used on the aircraft.

12.2 Repair

Repair of the propeller first involves evaluating the damage and determining whether the repair is to be a major or minor one. In general all damage except defective paint or small dents has to be rated as major repair. Refer also to propeller manufacturers manual for further instruction.

WARNING

We strongly recommend to replace propeller if any cracks, deteriorations of the skin or extended dents are determined.

12.3 Removal (refer to figure 12-1.)

- | | |
|--------------------------------|---|
| 12.3.1 Required Tools: | 3 & 6 mm allen wrench.screwdriver |
| 12.3.2 Parts required: | Safetying wire, 9x surface-screws (M4). |
| 12.3.3 Level of Maintenance: | Light |
| 12.2.4 Certification required: | Repairman Maintenance or Owner |

WARNING

Be sure master switch is in OFF position and key removed from starter switch before turning propeller.

- a. Remove spinner.

Note

The spinner (1) is attached to the rear bulkhead . These bulkheads are secured by the propeller mounting bolts (11) and will be free by removal of the bolts as the propeller is removed.

- b. Remove bolts and pull propeller forward to remove. Use care to avoid damage to bulkheads as propeller is removed.

Figure 12-1

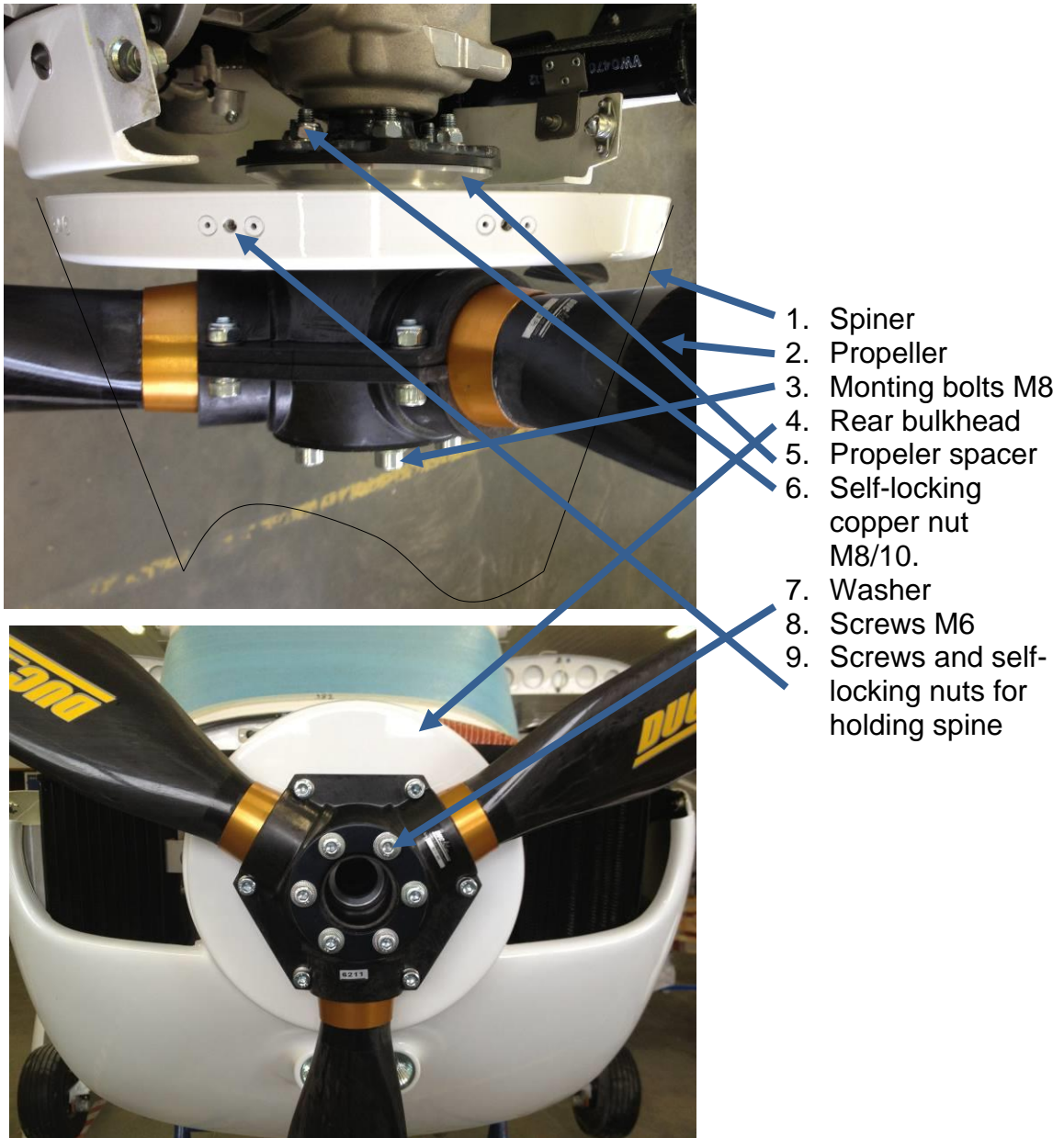

12.4 Installation (refer to figure 12-1.)

Clean mating surfaces of propeller, crankshaft flange and spinner bulkheads.

WARNING

Be sure master switch is in OFF position and key removed from starter switch before turning propeller.

- a. Install propeller and spinner bulkheads. The spinner bulkheads must be positioned so propeller blades will emerge from the spinner with ample clearance.
- b. Tighten the mounting bolts (3) evenly to a torque value of 20 Nm/176 in.lb.
- c. Safety wire propeller mounting bolts (3).
- d. Install spinner. When fitting the spinner use the fixing screws. Do not overtighten the fixing screws.

More information you can find in the Maintenance and installation manual from producer

Section 13

Utility systems

Table of contents	Page
13.1 Utility systems.....	13-0
13.2 Heating system.....	13-0
13.3 Description.....	13-0
13.4 Operation.....	13-0
13.5 Trouble shooting.....	13-0
13.6 Removal, installation and repair.....	13-1
13.7 Ventilating system.....	13-2
13.8 Description.....	13-2
13.9 Trouble shooting.....	13-2

13.1 Utility systems

13.2 Heating system

13.3 Description

The heating system is comprised of the heat exchange section of the exhaust muffler, a shut-off valve mounted on the center of the firewall, a push-pull control on the instrument panel, outlets, and flexible ducting connecting the system.

13.4 Operation

Ram air is ducted through a heat exchange section of the exhaust muffler, to the shut-off valve in a chamber on the rear side of the firewall, where it is distributed into the cabin. The shut-off valve operated by a push-pull control marked "Warm", located beneath the switch panel, regulates the volume of heated air entering the system. Pulling the control full out supplies maximum flow, and pushing control in gradually decreases flow, shutting off flow completely when the control is fully pushed in.

13.5 Trouble shooting

Most of the operational troubles in the heating and ventilating systems are caused by a sticking or binding air valve and its control, damaged air ducting, or defects in the exhaust muffler. In most cases, the valve or control can be freed by proper lubrication. Damaged or broken parts must be repaired or replaced. When checking control, ensure valve responds freely to the control movement, that they move in the correct direction, and that they move through their full

range of travel and seal properly. Check that hoses are properly secured, ensure to replace hoses that are burned, frayed or crushed. If fumes are detected in the cabin, a thorough inspection of the exhaust system should be accomplished. Refer to applicable paragraph in Section 10 for this inspection. Since any holes or cracks may permit exhaust fumes to enter the cabin, replacement of the defective parts is imperative because fumes constitute an extreme danger.

13.6 Removal, installation and repair

- | | |
|--------------------------------|---------------------------------------|
| 13.6.1 Required Tools: | Head screwdriver |
| 13.6.2 Parts required: | hoses and hose clamps as required. |
| 13.6.3 Level of Maintenance: | Light |
| 14.6.4 Certification required: | Repairman Maintenance or Owner |

Figure 13-1. illustrates the heating and ventilating systems, and may be used as a guide during removal, installation and repair of heating system components. Burned, frayed, or crushed hoses must be replaced with new hoses, cut to length and installed in the original routing. Trim hose winding shorter than the hose to allow clamps to be fitted. Defective air valves must be repaired or replaced. Check for proper operation of the valves and their controls after repair or replacement.

Figure 13-1

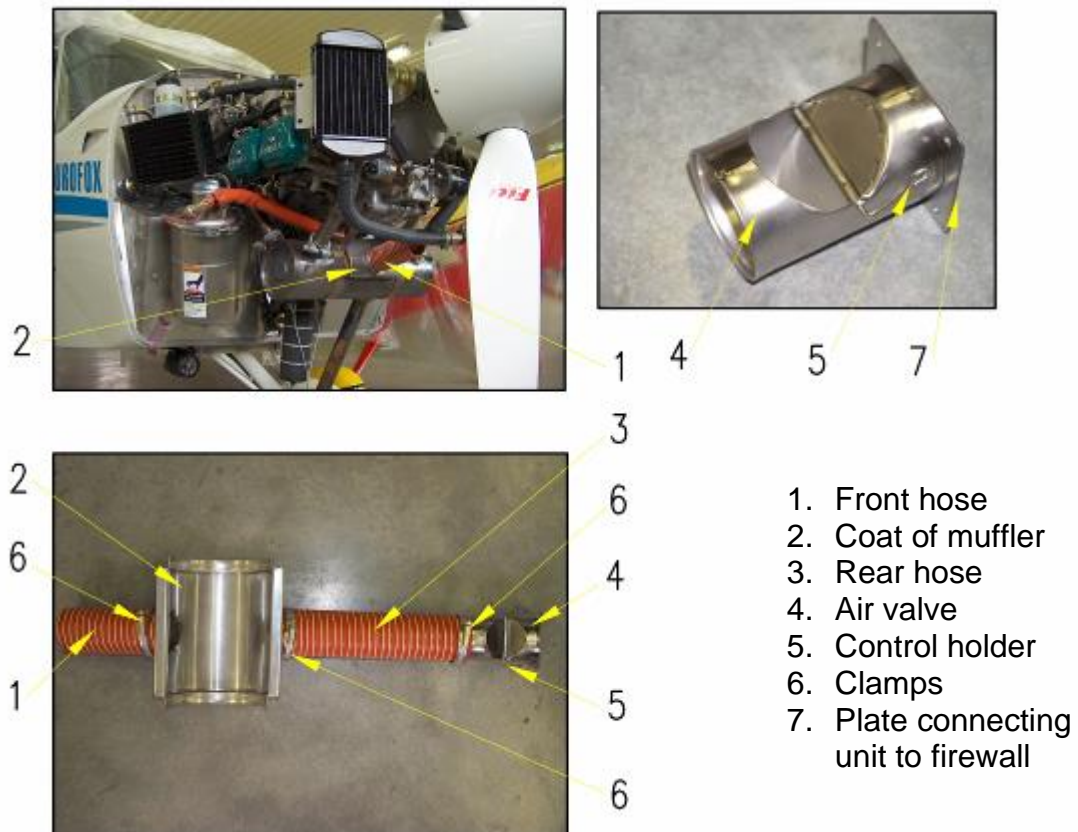

13.7 Ventilating system

13.8 Description (Figure 13-2)

The ventilating system is comprised of a naca-style fresh air-scoop mounted in the right and left side of the cowling behind of firewall. Each side has Independent shut-off valves. The shut-off valves are located on the top of instrument panel and are operated by rotating the valve shut-on/off disc anywhere from the fully open to fully closed position .

Figure 13-2

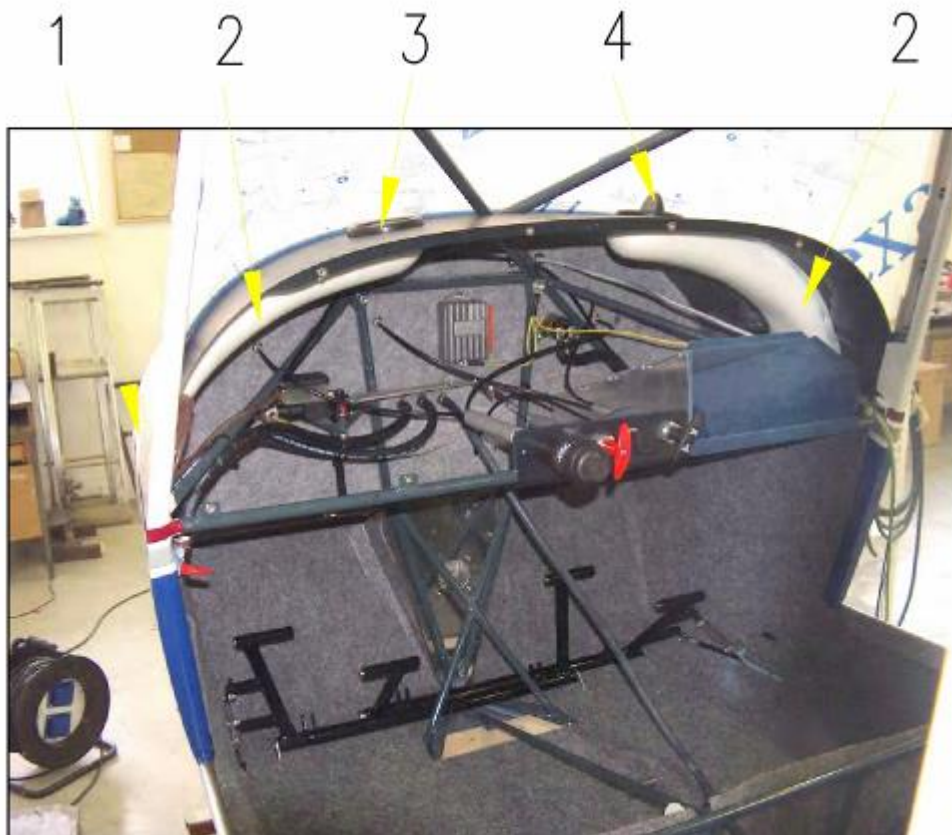

1. Naca fresh air-scoop
2. Tunnel for fresh air
3. Valve
4. Valve shut-on disc

13.9 Trouble shooting

Damaged or broken parts must be repaired or replaced.

Section 14

Instruments and instrument system

Table of contents	Page
14.1 Instruments and avionics.....	14-0
14.2 General.....	14-0
14.3 Instrument panel.....	14-1
14.4 Description.....	14-1
14.5 Removal and installation.....	14-1
14.6 Stationary panel.....	14-1
14.7 Mount panel.....	14-3
14.8 Pitot and static system.....	14-4
14.9 Description.....	14-4
14.10 Maintenance.....	14-4
14.11 Static pressure system inspection, leakage test...	14-4
14.12 Pitot system inspection, leakage test.....	14-5
14.13 Blowing out lines.....	14-5
14.14 Removing and installation of components.....	14-6
14.15 Trouble shooting-pitot static system.....	14-6
14.16 Trouble shooting airspeed indicator.....	14-7
14.17 Trouble shooting altimeter.....	14-7
14.18 Trouble shooting vertical speed indicator.....	14-8
14.19 Engine indicators.....	14-9
14.20 Rotax Flydat system.....	14-9
14.21 Description.....	14-9
14.22 Removal and installation.....	14-9
14.23 Trouble shooting.....	14-10
14.24 Magnetic compass.....	14-10
14.25 Description.....	14-10
14.26 Slip indicator.....	14-10

14.1 Instrument and instrument systems

14.2 General

This section describes typical instrument installations and their respective operating systems. Emphasis is placed on trouble shooting and corrective measures only. It does not deal with specific instrument repairs since this usually requires special equipment and data and should be handled by instrument specialists. Federal Aviation Regulations require malfunctioning instruments be sent to an approved instrument overhaul and repair station or returned to manufacturer for servicing. Our concern here is with preventive maintenance on various instrument systems and correction of system faults which result in instrument malfunctions. The descriptive material, maintenance and trouble

shooting information in this section is intended to help the mechanic determine malfunctions and correct them, up to the defective instrument itself, at which point an instrument technician should be called in. Some instruments, such as fuel quantity and oil pressure gauges, are so simple and inexpensive, repairs usually will be more costly than a new instrument. On the other hand, aneroid and gyro instruments usually are well worth repairing. The word “replace instrument” in the text, therefore, should be taken only in the sense of physical replacement in aircraft. Whether replacement is to be with a new instrument, an exchange one, or original instrument is to be repaired must be decided on basis of individual circumstances.

14.3 Instrument panel (refer to figure 14-1.)

14.4 Description

The instrument panel assembly consists of a stationary and mounted panel. The stationary panel contains controls such as the throttle, brake, carburetor heat, choke and cockpit heating. The mounted panel contains major flight instruments such as the airspeed indicator, altitude indicator, EFIS-systems, avionics components, and horizontal and directional gyros. Most of the instruments are screw-mounted on the aluminum frame backs.

14.5 Removal and installation

14.5.1 Required Tools:	Wrench, 10 mm wrench, screwdriver
14.5.2 Parts required:	Cable ties, insulating tape.
14.5.3 Level of Maintenance:	Light
14.5.4 Certification required:	Repairman Maintenance or Owner

14.6 Stationary panel

The stationary panel is located at the lower center section of the cockpit frame. It consists of a metal support frame and a decorative aluminium cover. To remove the stationary panel proceed as follows:

- a. Disconnect battery leads and remove instrument panel.
- b. Loosen and unscrew the following controls devices:- throttle, carburetor heat, brake, cockpit heating and choke.

14.7 Mount panel

The mounted panels consist of an aluminum support frame and a decorative painting cover attached to the cockpit main-frame via 9 x screws . To remove a shock-mount panel proceed as follows:

- a. Disconnect battery leads and insulate the radio or GPS
- b. Unscrew retaining screws and remove aluminium instrument panel.
- c. Pull out the upper edge of the frame and lift up to disengage the lower edge from the cockpit main-frame.
- d. Disconnect wiring and hoses and remove panel.
- e. Reverse preceding steps for reinstallation.

Figure 14-2

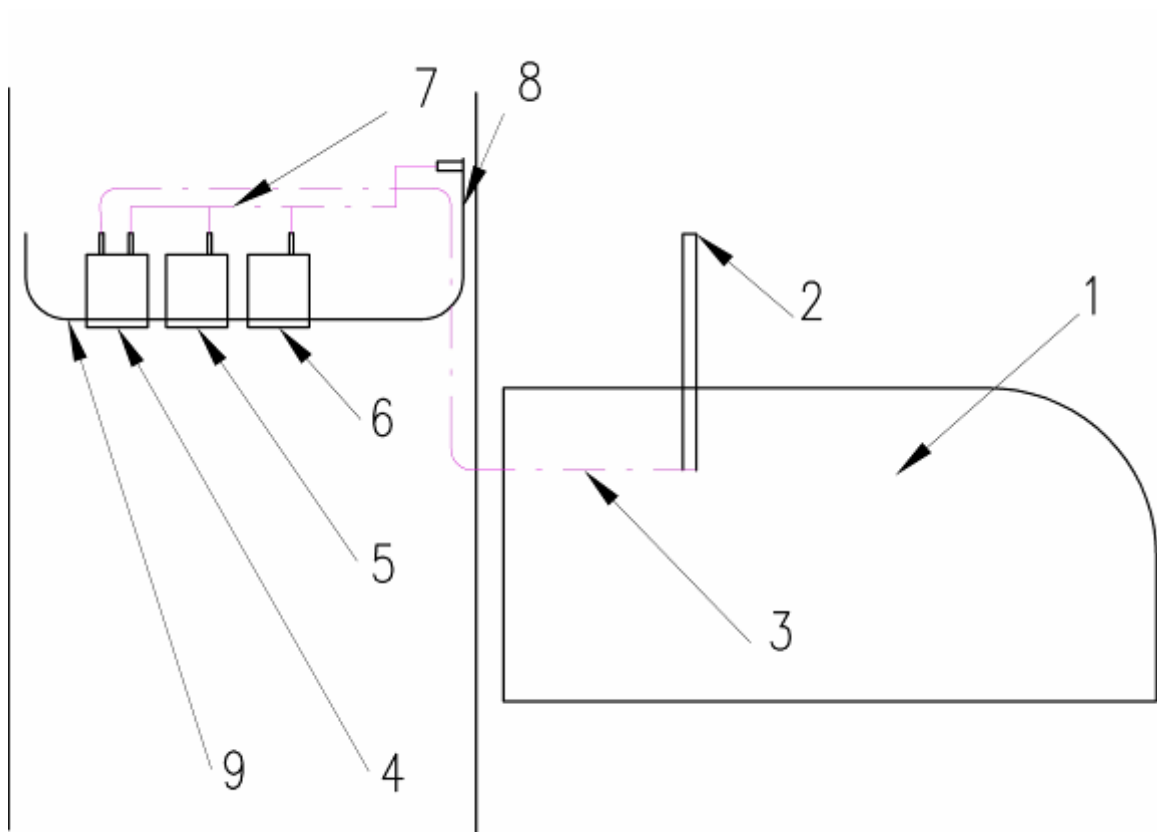

- | | |
|-----------------------------|-----------------------------|
| 1. Right wing | 7. Hose for static pressure |
| 2. Pitot tub | 8. Static port |
| 3. Hose dynamic pressure | 9. Instrument panel |
| 4. Air speed indicator | |
| 5. Vertical speed indicator | |
| 6. Altimeter | |

14.8 Pitot and static system (refer to figure 14-2.)

14.9 Description

The pitot system conveys ram air pressure to the airspeed indicator. The static system vents the vertical speed indicator, altimeter and airspeed indicator to atmospheric pressure through plastic hoses connected to a static port on the fuselage.

14.10 Maintenance

Proper maintenance of pitot and static system is essential for proper operation of altimeter, vertical speed and airspeed indicator. Leaks, moisture and obstructions in the pitot system will result in false airspeed indications, while static system malfunctions will affect readings of all three instruments. Cleanliness and security are the principal requirements for system maintenance. The pitot tube and static ports **MUST** be kept clean and unobstructed for safe operation.

14.11 Static pressure system inspection and leakage test

The following procedure outlines the inspection and testing of the static pressure system, assuming the altimeter has been tested and inspected in accordance with current Federal Aviation Regulations.

- a. Ensure the static system is free from entrapped moisture and restrictions.
- b. Ensure no alterations or deformations of airframe surface have been made which would affect the relationship between air pressure in static pressure system and true ambient static air pressure for any flight configuration.
- c. Attach a source of suction to one static pressure source opening while covering the static pressure vent on the opposite side of the fuselage.
- d. Slowly apply suction until the altimeter indicates a 1000-foot increase in altitude.

Caution

When applying or releasing suction, do not exceed range of the vertical speed indicator or airspeed indicator.

- e. Remove the suction source and maintain a “closed” system for one minute. Leakage should not exceed 100 feet of altitude loss as indicated on altimeter during the one minute.
- f. If leakage rate is within tolerance, slowly release suction source.

Note

If leakage rate exceeds maximum allowable, first check all connections, then repeat the leakage test. If leakage rate still exceeds maximum allowable, use the following procedure.

- g. Disconnect the static pressure line from the airspeed indicator and vertical speed indicator. Use suitable fittings to connect hoses together so altimeter is the only instrument still connected into static pressure system.
- h. Repeat leakage test to check whether static pressure system or the bypassed instruments are the cause of the leakage. If instruments are at fault, they must be repaired by an “appropriately rated repair station” or replaced. If static pressure system is at fault, use following procedure to locate leakage.
- i. Attach a source of positive pressure to static source opening.

Caution

Do not apply positive pressure with airspeed indicator or vertical speed indicator connected to static pressure system.

- j. Slowly apply positive pressure until altimeter indicates a 500-ft decrease in altitude and maintain this altimeter indication while checking for leaks. Coat line and static source connections with solution of mild soap and water, watching for bubbles to locate leaks.
- k. Repair or replace parts found defective.
- l. Reconnect the airspeed and vertical speed indicators into the static pressure system and repeat leakage test per steps **c** through **f**.

14.12 Pitot system inspection, leakage test

To check pitot system for leaks, fasten a piece of rubber or plastic tubing over the pitot tube, close opposite end of tubing and slowly roll up the tube until airspeed indicator registers in the cruise range. Secure tube and after a few minutes recheck airspeed indicator. Any leakage will have reduced the pressure in system, resulting in a lower airspeed indication. Slowly unroll the tubing before removing it, so pressure is reduced gradually. Otherwise the instrument may be damaged. If test reveals a leak in system, check all connections.

14.13 Blowing out lines

Condensation may collect in the system and produce a partial obstruction. To clear the hose, disconnect it at the airspeed indicator. Gently blow from the indicator end of line toward the pitot tube.

Caution

Never blow through pitot or static lines towards instruments.

Like pitot lines, static pressure lines must be kept clear and connected safely. When necessary, disconnect static line at first instrument to which it is connected, then gently blow the line clear. Check all the static pressure line connections. If hose or hose connections are used, check them for general condition and security. Replace any hose which has cracked, hardened or show other signs of deterioration.

14.14 Removing and installation of components (refer to figure 14-1, 14-2.)

- 14.14.1 Required Tools: Edge cutter
 14.14.2 Parts required: Cable ties, hoses as required.
 14.14.3 Level of Maintenance: **Light**
 14.14.4 Certification required: **Repairman Maintenance or Owner**

To remove the pitot tube, unscrew the retaining nut and withdraw the tube from the support tube. A pitot line running within the left wing is fixed inside the wing and can not be removed if damage to the original pitot line inside the wing is detected. The pitot line is connected to the fuselage adjacent to the root rib, access is possible when the left wing is folded back (refer to Pilot Operators Handbook).

14.15 Trouble shooting - Pitot static system

Trouble	Probable Cause	Remedy
Low or sluggish airspeed indication (normal altimeter and vertical speed).	Pitot tube obstructed, leak or obstruction in pitot line.	Test pitot tube and line for leaks or obstructions. Blow out tube and line, repair or replace damaged line.
Incorrect or sluggish response (all three instruments).	Leaks or obstructions in static line.	Test line for leaks and obstructions. Repair or replace line, blow out obstructed line.

14.16 Trouble shooting - Airspeed indicator

Trouble	Probable Cause	Remedy
Pointer fails to respond.	Pitot pressure connection not properly connected to pressure line from pitot tube.	Test line and connection for leaks. Repair or replace damaged line.
	Pitot or static lines clogged.	Check line for obstructions. Blow out lines.
Incorrect indication or pointer oscillates.	Leak in pitot or static lines.	Test lines and connections for leaks. Repair or replace damaged lines.
	Defective mechanism or leaking diaphragm.	Substitute known-good indicator and check reading. Replace indicator.
Pointer vibrates.	Excessive vibration.	Check panel shock mounts and replace if required.
	Excessive tubing vibration.	Check clamps, cable ties and line connections for security.

14.17 Trouble shooting - Altimeter

Trouble	Probable Cause	Remedy
Instrument fails to operate.	Static line plugged.	Check line for obstructions. Blow out lines.
	Defective mechanism.	Substitute known-good altimeter and check reading. Replace indicator.
Incorrect indication.	Pointer not carefully set.	Reset hands with knob.
	Leaking diaphragm.	Substitute known-good altimeter and check reading. Replace indicator.
	Pointers out of calibration.	Compare reading with known-good altimeter. Replace indicator.

Pointer oscillates.	Static pressure irregular.	Check lines for obstruction or leaks. Blow out lines.
	Leak in airspeed or vertical speed indicator installations.	Check other instruments and system plumbing for leaks. Blow out lines.

14.18 Trouble shooting - Vertical speed indicator

Trouble	Probable Cause	Remedy
Instrument fails to operate.	Static line plugged.	Check line for obstructions. Blow out lines.
	Static line broken	Check line for damage, connections for security. Repair or replace damaged line.
Incorrect indication.	Partially plugged static line.	Check line for obstructions. Blow out line.
	Ruptured diaphragm.	Substitute known-good indicator and check reading. Replace indicator.
	Pointer off zero.	Reset pointer to zero.
Pointer oscillates.	Partially plugged static line.	Check line for obstructions. Blow out lines.

14.19 Engine indicators

14.20 Rotax Flydat system

14.21 Description

The Flydat represents an instrument specially developed for Rotax aircraft engines for the indication and acquisition of engine operating data readily accessible for the pilot. The Flydat provides the following indicators: Engine speed, cylinder head temperature, oil temperature, oil pressure, exhaust gas temperatures, operation hours.

The operating data is being permanently compared with the specific engine operating limit. If the signalled operating data exceeds the stored operating limits, the Flydat will warn the pilot by means of a warning light.

14.22 Removal and installation

14.26.1 Required Tools: 3 mm allen wrench, screwdriver, edge cutter.

14.26.2 Parts required: Cable ties, 4 x self-locking nut (M4).

14.26.3 Level of Maintenance: **Light**

14.26.4 Certification required: **Repairman Maintenance or Owner**

- a. Disconnect battery leads and insulate as safety precaution.
- b. Unscrew the nine screws which hold the aluminium instrument panel
- c. Pull out the upper edge of the frame and lift up to disengage the lower edge from the cockpit main-frame.
- d. Disconnect the wiring and hoses and remove panel.
- e. Unscrew and remove the Flydat.
- f. Reverse the preceding steps for reinstallation.

14.23 Trouble shooting

Trouble	Probable Cause	Remedy
Flydat fails to operate.	Low battery voltage.	Check, recharge or replace battery. Refer to Section 2.
	Blown fuse or circuit breaker.	Replace fuse or reset circuit breaker.
	Defective Flydat.	Substitute known-good Flydat and check operation. Replace Flydat.
Incorrect Indication	Defective sensor.	Replace sensor.
	Improper connection.	Check terminals, repair or replace defective parts.
No reading / dashes	Broken wiring or damaged connectors.	Check wiring and connections, repair or replace defective parts.
	Defective Flydat.	Substitute known-good Flydat and check operation. Replace Flydat.

14.24 Magnetic compass

14.25 Description

The magnetic compass is liquid-filled, with expansion provisions to compensate for temperature changes. It is equipped with compensating magnets adjustable from front of case. No maintenance is required on compass except on occasional check on a compass rose for adjustment of compensation.

14.26 Slip indicator.

A slip indicator is provided on the left panel. The slip indicator needs no servicing at all.

Section 15

Electrical systems

Table of contents		Page
15.1	Electrical system.....	15-2
15.2	General.....	15-2
15.3	Electrical power supply system.....	15-2
15.4	Description.....	15-2
15.5	Master wiring system.....	15-2
15.6	Switch panel.....	15-3
15.7	Master switch.....	15-3
15.8	Avionics master switch.....	15-3
15.9	Ignition and magneto switch.....	15-3
15.10	Automatic circuit breaker panel.....	15-3
15.11	Optional equipment.....	15-3
15.12	Connecting optional instruments.....	15-3
15.13	Conncting avionic devices.....	15-4
15.14	Battery power system.....	15-4
15.15	Battery.....	15-4
15.16	Description.....	15-4
15.17	Removal and installation.....	15-4
15.18	Trouble shooting battery power system.....	15-5
15.19	Cleaning the battery.....	15-5
15.20	Testing the battery.....	15-6
15.21	Charging the battery.....	15-6
15.22	Alternator power system.....	15-6
15.23	Description.....	15-6
15.24	Removal and installation.....	15-6
15.25	Trouble shooting the alternator.....	15-6
15.26	Voltage rectifier regulator.....	15-6
15.27	Description.....	15-6
15.28	Removal and installation.....	15-7
15.29	Testing the voltage regulator.....	15-7
15.30	Trouble shooting	15-7
15.31	Aircraft lighting system.....	15-7
15.32	Description.....	15-7
15.33	Trouble shooting.....	15-8
15.34	Navigation lights.....	15-9
15.35	Description.....	15-9
15.36	Removal and installation.....	15-9
15.37	Anti collision strobe light.....	15-10
15.38	Description.....	15-10
15.39	Removal and installation.....	15-10

Table of contents (continued)		Page
15.40	Instrument/avionics lighting.....	15-10
15.41	Description.....	15-10
15.42	Removal and installation.....	15-10
15.43	External receptacle.....	15-10
15.44	Description.....	15-10
15.45	Removal and installation.....	15-11
15.46	Alterations.....	15-11
15.47	Emergency Locator Transmitter.....	15-11
15.48	Description.....	15-11
15.49	Installation.....	15-11
15.50	Antenna installation.....	15-11
15.51	Landing lights.....	15-12
15.52	Description.....	15-12
15.53	Installation.....	15-12
15.54	Electrical load analysis chart.....	15-13

15.1 Electrical system

15.2 General

This section contains service information necessary to maintain the aircraft electrical power supply system, battery, alternator power system, aircraft lighting system and electrical load analysis.

15.3 Electrical power supply system

15.4 Description

Electrical energy for the aircraft is supplied by a 14-volt, direct-current, single-wire, negative ground electrical system. A 12-volt battery supplies power for starting and furnishes a reserve source of power in the event of alternator failure. An engine driven alternator is the normal source of power during flight and maintains a battery charge controlled by a voltage regulator.

15.5 Master wiring system

The aircraft is equipped with a master wiring system, featuring various terminal connectors to provide easy installation of additional electric equipment. The master wiring also provides a master power bus and an avionics power bus system. Refer to Section 18 for detailed wiring diagrams.

15.6 Switch panel

A switch panel is located at the right hand side of the instrument panel. All switches are located in this area, apart from the keyed and magneto switches which are located opposite of the instrument panel.

15.7 Keyed switch

The keyed switch is located below the magneto switches. The keyed switch operates the battery and alternator system. The switch, when operated, connects the battery to the engine wiring system, activating the power systems.

15.8 Avionics switches

When the avionics switches is operated, power to the avionics bus system is enabled. The avionics bus system provides power to all the electrical devices like radio, intercom, transponder, GPS, attitude indicator, directional indicator, EFIS system (if fitted).

15.9 Ignition and magneto switches

Two magneto switches are installed on the left hand side of the instrument panel above the starter button, both magneto switches are protected by metal sidewalls. Starting the engine is only possible after the keyed switch and the ignitions switches are in the on position.

Warning

Switching off the keyed switch while engine running will damage the voltage regulator with serious damage to all installed electronic equipment.

15.10 Automatic circuit breakers panel

The circuit breakers are installed on the right side of instrument panel. The panel provides 6 automatic circuit breakers for the avionics bus system.

15.11 Optional equipment

15.12 Connecting optional instruments

The master wiring system of the aircraft provides terminal connectors for various extensions such as: Voltage indicator, exhaust gas indicators, oil temperature gauge, oil pressure gauge, rpm gauge, clock and more. Extension wiring systems are available for most instruments. (refer to Section 19)

15.13 Connecting avionics devices

The avionics wiring system of the aircraft provides terminal connectors for various extensions like: Radio, intercom, transponder, GPS, attitude-gyro,

directional-gyro, EFIS-display system, turn indicator. Extension wiring systems are available for most instruments (refer to Section 19).

15.14 Battery power system

15.15 Battery

15.16 Description

The battery is 12 volts and is approximately 16 ampere-hour capacity. The battery is mounted below the right seat. The battery installation is sealed and so requires no maintenance.

15.17 Removal and installation

16.19.1 Required Tools:	Screwdriver, set of wrench.
16.19.2 Parts required:	None
16.19.3 Level of Maintenance:	Light
16.19.4 Certification required:	Repairman Maintenance or Owner

- a. Remove the seat.
- b. Remove the battery retaining strap.
- c. Disconnect the ground cable from the negative battery terminal.

Caution	When installing or removing battery, always observe the proper polarity with the aircraft electrical system (negative to ground). Reversing the polarity, even momentarily, may result in the failure of semiconductor devices (regulator diodes, radio protection diodes and radio transistors).
----------------	---

- d. Disconnect the cable from the positive terminal of the battery.
- e. Lift the battery out of the battery box.
- f. To replace the battery, reverse preceding steps.

15.18 Trouble shooting

Trouble	Probable Cause	Remedy
Battery will not supply power to electrical system or crank engine.	Battery discharged.	1. Measure voltage at battery terminal with master switch and suitable load turned on. Normal battery will indicate 11.5 – 12.0 volts. If voltage is low, proceed to step 2. If voltage is normal, proceed to step 3.

	Battery faulty.	2. Charge battery in accordance with charging information found on the battery. If battery voltage drops below 11.5 volts 12 hours after charging, when connected to the aircraft with master switch turned on, replace battery.
	Faulty wiring.	3. Check voltage on master fuse/circuit breaker. Voltage shall not indicate more than 0.3 volts below battery voltage. Replace defective wiring, master switch or connectors.

15.19 Cleaning the battery

For maximum efficiency the battery and connections should be kept clean at all times.

- a. Remove the battery and connections in accordance with the preceding paragraph.
- b. Wipe the battery cable ends, battery terminals and the entire surface of the battery with a clean cloth moistened with a solution of bicarbonate soda (baking soda) and water.
- c. Rinse with clear water, wipe off excess water and allow battery to dry.
- d. Brighten up cable ends and battery terminals with emery cloth or a wire brush.
- e. Install the battery according to the preceding paragraphs.
- f. Coat the battery terminals with an ignition spray product to reduce corrosion.

15.20 Testing the battery

When battery is disconnected from the electrical system of the aircraft, voltage measuring should indicate 12.2 volts or above (regular 12.5 volts). If battery voltage is below 12.2 volts, battery needs to be charged. When battery voltage is below 11.8 volts battery has to be replaced.

15.21 Charging the battery

Battery shall be charged only when disconnected from the aircraft. Charge battery in accordance to the charging instructions found on the battery.

15.22 Alternator power system

15.23 Description

The alternator is an integral part of the engine, rated at 14 volts at 20 amperes continuous output. The output signal is fed to an external rectifier regulator provided in the aircraft electrical system.

15.24 Removal and installation

Refer to the Rotax maintenance manual for information about the removal and installation of the engine alternator system.

15.25 Trouble shooting

Refer to the Rotax maintenance manual for information about trouble shooting for the engine alternator system.

15.26 Voltage rectifier regulator

15.27 Description

The rectifier regulator is located on the right internal side of the firewall. Feeding wires from the alternator (left side of ignition housing on the engine) are routed directly to the regulator. The resulting dc output is applied to the aircraft battery and master wiring system.

15.28 Removal and installation

- 16.30.1 Required Tools: 4 mm allen wrench, 8 & 10 mm wrench, screwdriver.
16.30.2 Parts required: 2 x self-locking nut (M5), insulating tape.
16.30.3 Level of Maintenance: **Light**
16.30.4 Certification required: **Repairman Maintenance or Owner**

- a. Remove the cowling, instrument panel and seat.
- b. Disconnect battery leads and insulate as a safety precaution.
- c. Unplug the terminal connector on the regulator case.
- d. Unscrew and remove the regulator from the firewall.
- e. Reverse preceding steps for reinstallation.

15.29 Testing the voltage regulator

Measure the system voltage on the master fuse/circuit breaker (furthest left on fuse panel), the voltage should indicate 14.0 +/- 0.3 volts with engine running.

15.30 Trouble shooting

Refer to the Rotax maintenance manual for information about trouble shooting of the engine alternator system.

15.31 Aircraft lighting system

15.32 Description

The aircraft lighting system consists of navigation lights, a landing light (if fitted), anticollision strobe lights and instrument lights. All electrical switches to control the lighting system are located on the switch panel as outlined in paragraph 15.6.

15.33 Trouble shooting

Trouble	Probable Cause	Remedy
Landing light out.	Short circuit in wiring.	1. Inspect fuse/circuit breaker. If open, proceed to step 2. If OK, proceed to step 3.
	Defective wiring.	2. Test each circuit separately until short is located. Repair or replace wiring.
	Defective switch.	3. Check voltage at light with master switch and landing light switch ON. Should read battery voltage. Replace switch.

All nav lights out.	Short circuit in wiring.	1. Inspect fuse/circuit breaker. If open, proceed to step 2. If OK, proceed to step 3.
	Defective wiring.	2. Test each circuit separately until short is located. Repair or replace wiring.
	Defective switch.	3. Check voltage at nav lights with master switch and nav light switch ON. Should read battery voltage. Replace switch.
One nav light out.	Lamp burned out.	Inspect lamp, replace lamp.
	Open circuit in wiring.	Test wiring for continuity. Repair or replace wiring.
Anti-collision strobe light out.	Flash tube burned out.	Test with new tube, Replace tube.
	Faulty wiring.	Test for continuity, Repair or replace.
	Faulty power supply.	Test with new power supply, Replace power supply.
	Circuit breaker open or fuse blown.	Inspect, reset.
	Faulty switch.	Test for continuity, Repair or replace.
Instrument lights will not light.	Short circuit in wiring.	1. Inspect fuse/circuit breaker. If open, proceed to step 2. If OK, proceed to step 3.
	Defective wiring.	2. Test each circuit separately until short is located. Repair or replace wiring.
	Defective switch.	3. Check voltage at lights with master switch and instrument light switch ON. Should read battery voltage. Replace switch.
	Lamps burned out.	Inspect lamps, replace lamps.

15.34 Navigation lights

15.35 Description

The navigation lights are located on each wing tip. The lights are controlled by a rocker type switch located on the switch panel.

15.36 Removal and installation

- 16.38.1 Required Tools: Screwdriver
16.38.2 Parts required: None
16.38.3 Level of Maintenance: **Light**
16.38.4 Certification required: **Owner**
- Unscrew and remove the colored protective cover.
 - Withdraw and unplug the lamp.
 - Reverse the preceding steps for reinstallation.

Caution

Do not overtighten the cover fixing screws at reinstallation, to prevent the cover from cracking.

15.37 Anti collision strobe light

15.38 Description

A white strobe light is installed on top of the rudder (if fitted) and is vibration resistant and operates on the principle of a capacitor discharge into a xenon tube, producing an extremely high intensity flash. Energy is supplied to the strobe light from a power supply mounted in the cargo compartment behind the seats.

15.39 Removal and installation

To replace flash tube, unscrew light from top of the rudder and disconnect from power supply. To replace power supply, the rudder must first be removed, then follow the description below:

- Unscrew the access plate from the rudder.
- Unscrew, disconnect and remove the power supply.
- Reverse preceding steps for reinstallation.

15.40 Instrument and avionics lighting

15.41 Description

All installed instruments, which are equipped with internal lights, are connected to the lighting system of the aircraft. Power to the instrument and avionics lights is provided by a rocker-type switch on the switch panel.

15.42 Removal and installation

Refer to the appropriate user manuals provided with the instruments and avionics devices for instructions about replacement of instruments and avionics lights.

15.43 External receptacle

15.44 Description

A receptacle way for connecting external equipment like GPS is installed on top of the rear cabin bulkhead, between both seats. The receptacle provides 12 volt (positive lead on center terminal). A special adapter to connect a cigar lighter plug can be obtained from the factory or at most automobile parts suppliers.

15.45 Removal and installation

16.47.1 Required Tools: set of wrench, soldering iron.

16.47.2 Parts required: Cable ties, insulating tape, solder.

16.47.3 Level of Maintenance: **Light**

16.47.4 Certification required: **Repairman Maintenance or Owner**

To remove the external receptacle, removal of the baggage compartment is first required (refer to Section 3.), then proceed as outlined below.

- a. Disconnect the battery leads and insulate as safety precaution.
- b. Disconnect the wiring from the receptacle, note wiring for reinstallation.
- c. Unscrew and remove the receptacle
- d. Reverse preceding steps for reinstallation.

15.46 Alterations

15.47 Emergency Locator Transmitter

15.48 Description

The ELT is a self-contained, solid state unit, with its own power supply, with an externally mounted antenna. The ACK-E01 transmitter is designed to transmit a frequency of 121.5 Megahertz. Power is supplied to the transmitter by a battery-pack which has the service life placarded on the batteries. The ELT is equipped with a battery-pack containing 8 alkaline "D" size dry cell batteries wired in series. A rocker type switch at the forward side of the ELT is provided to arm or manually operate the system (for example for testing purposes).

15.49 Installation

The ELT comes with installation bracket which has to be screwed to the top of the rear cabin bulkhead. Refer to figure 15-1. for detailed information

15.50 Antenna installation

Refer to figure 15-1. for detailed information of antenna installation.

15.51 Landing light

15.52 Description

The landing light is mounted on the front of the lower engine cowling. This position facilitates the use of one lamp as both a landing and a taxi light. A light cover provides weather protection for the lamp. The landing and taxi light is controlled by a rocker type switch located on the switch panel.

15.53 Installation

For installation of the landing light, refer to figure 15-1. The basic equipment of the aircraft already contains the electrical wiring including a switch inside the cabin. Therefore installation is limited to running appropriate wiring from the connector box located forward of the firewall to the lamp position on the lower cowling. The position light set contains required wiring, including connectors, terminals, lamp assembly and fasteners. The complete lamp set can be obtained from the factory.

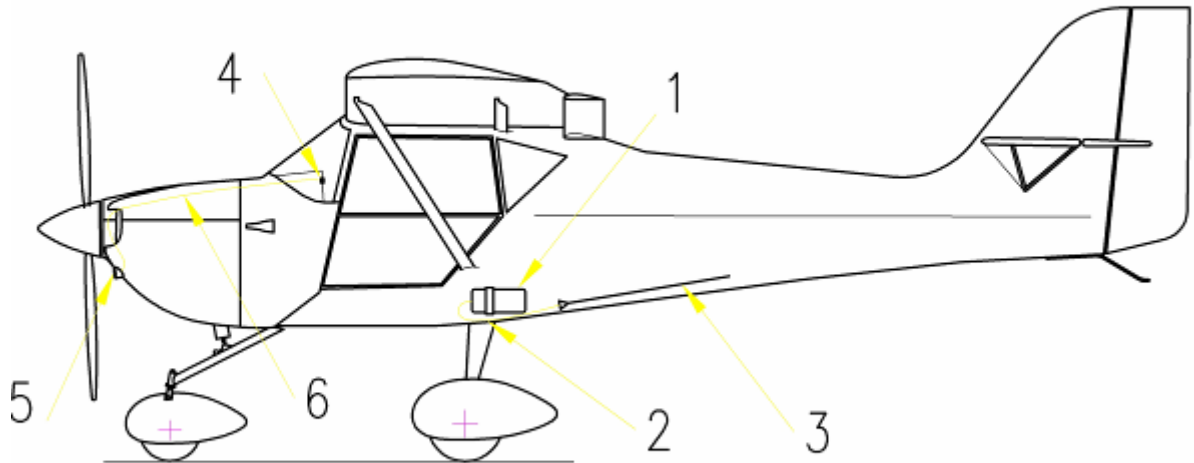
Figure 15-1

1. Emergency locator transmitter (ELT)
2. Antenne cable
3. Antenne
4. Swicher for landing light
5. Landing light
6. Cable for landing light

15.54 Electrical load analysis chart

Standard equipment (running load)	Amps
Fuel indicator.....	*
Fuel pump.....	1.0
Anti collision strobe light.....	3.0
Navigation lights.....	3.4
Rotax Flydat.....	0.4
Optional equipment (running load)	
Becker ATC 4401.1 transponder.....	1.3
Becker AR 4201 radio.....	0.5 - 2.5
Bendix King KT-76A transponder.....	1.3
Bendix King KT-76C transponder.....	1.4



Bendix King KY-97 radio.....	0.7 – 6.0
Bendix King KX-125 nav/com.....	1.0 - 6.0
Bendix King Skyforce IIIC GPS.....	1.0
Dynon Avionics EFIS D-10A EFIS.....	0.3
Falcon Gauge GH02E-3 attitude gyro.....	0.4
Falcon Gauge DG02E-3 directional gyro.....	0.4
Falcon Gauge TC02E-3-1 turn indicator.....	0.4
Garmin GTX 320 transponder.....	1.3
Garmin GTX 327 transponder.....	1.4
Garmin GPS Map 296 GPS.....	1.0
Garmin GPS Map 196 GPS.....	1.0
Microair M-760 radio.....	0.5 - 2.5
PS Engineering PM-1000II intercom.....	0.2
PS Engineering PM 501 intercom.....	0.2
Sigtronic SPA-400 intercom.....	0.2
Items not considered as part of running load	
External receptacle.....	max. 4.0
Clock.....	*
Instrument lights (depending on installed equipment).....	0.4-0.7
Flap motor.....	2.0
Landing light.....	4.6

* Negligible

Section 16

Structural repair

Table of contents		Page
16.1	Structural repair.....	16-1
16.2	Repair criteria.....	16-1
16.3	General consideration for welding frame repair.....	16-1
16.4	Repair of aircraft skin	16-2
16.5	Repair of fiberglass parts.....	16-2
16.6	Damages of larger extent.....	16-2

16.1 Structural repair

16.2 Repair criteria

Although this section outlines repairs permissible on the structure of the aircraft, the decision of whether to repair or replace a major unit of structure will be influenced by such factors as time and labor available, and by a comparison of labor costs with the price of replacement assemblies. Past experience indicates that replacement, in many cases, is less costly than major repair. Certainly, when the aircraft must be restored to its airworthy condition in a limited length of time, replacement is preferable. Restoration of a damaged aircraft to its original design strength, shape, and alignment involves careful evaluation of the damage, followed by exacting workmanship in performing the repairs. This section suggests the extent of structural repair practicable on the aircraft, and supplements Federal Aviation Regulation, Part 43. Consult the factory when in doubt about a repair not specifically mentioned here.

16.3 General consideration for welded frame repair

Minor damages, not affecting the aircraft airworthiness, may be repaired provided the scope of work does not extend beyond cases described below:

The operator is allowed to carry out only such repairs of the lattice-work in operation that do not require either use of a welding equipment or application of thermal treatment for straightening. Straightening of such structural members is permitted if, the deflection does not exceed 3% member length-member diameter ratio. A **local** deflection (depression) not exceeding 5% of tube dimension in its diameter can be considered admissible provided this tube is not damaged by cracks or some other non-reversible deformation.

16.4 Repair of aircraft skin

If damage occurs under operation, the skin can be repaired by replacing the whole part of the damaged fabric, or by a local repair using a patch. Such repairs may be carried out using the same materials as applied at aircraft fabrication.

16.5 Repair of fiberglass parts

If damage to these parts occurs, only a repair with use of epoxy resins and fiberglass cloth is applicable. It is necessary to thoroughly clean the surface of the parts under repair up to the base material and to remove any grease and paint. When making repairs, follow the manufacturers directions for the use of epoxy materials.

16.6 Damages of larger extent.

When damages of larger extent is found, we recommend to consult the manufacturer. Always replace parts and components with parts and components of the same material specification.

Section 17

Exterior painting

The exterior painting of the aircraft consists of 3-components acrylic lacquer system from DUPONT. Paint code: be dependent on Colour scale RAL.

Note	Do not paint the pitot tube, gas caps or antenna covers which were not painted by the factory.
-------------	--

Caution	Avoid thinner coming in contact with ABS parts or windows. These areas should be cleaned with soap and water and / or naphtha. Do not use strong solvents such as xylol, toluol, or lacquer thinners.
----------------	---

Section 18

Wiring diagrams

Table of contents	Page
18.1 General wiring scheme	18-2
18.2 Radio – intercom wiring	18-4
18.3 Transponder – encoder wiring	18-5

18.1 General wiring scheme

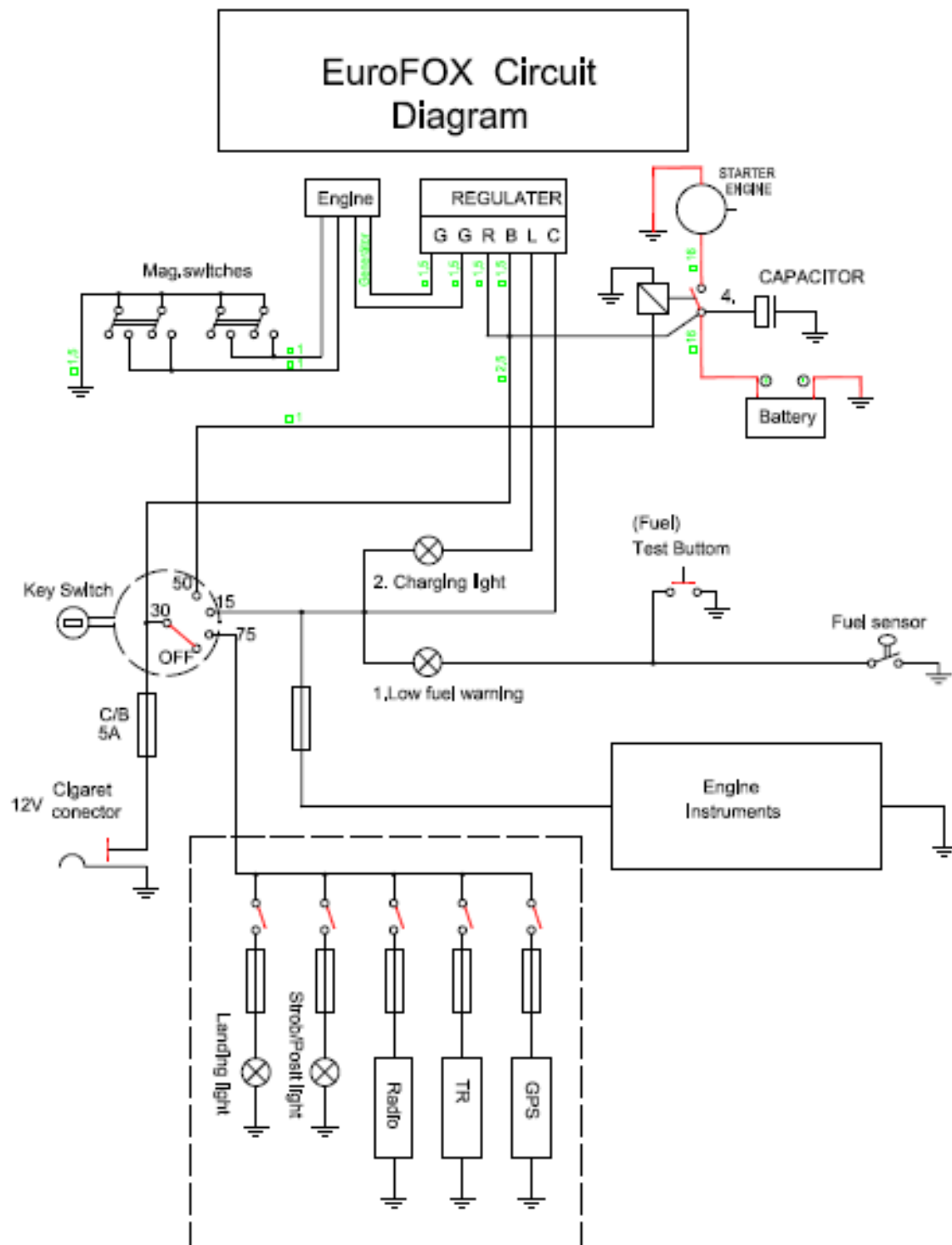

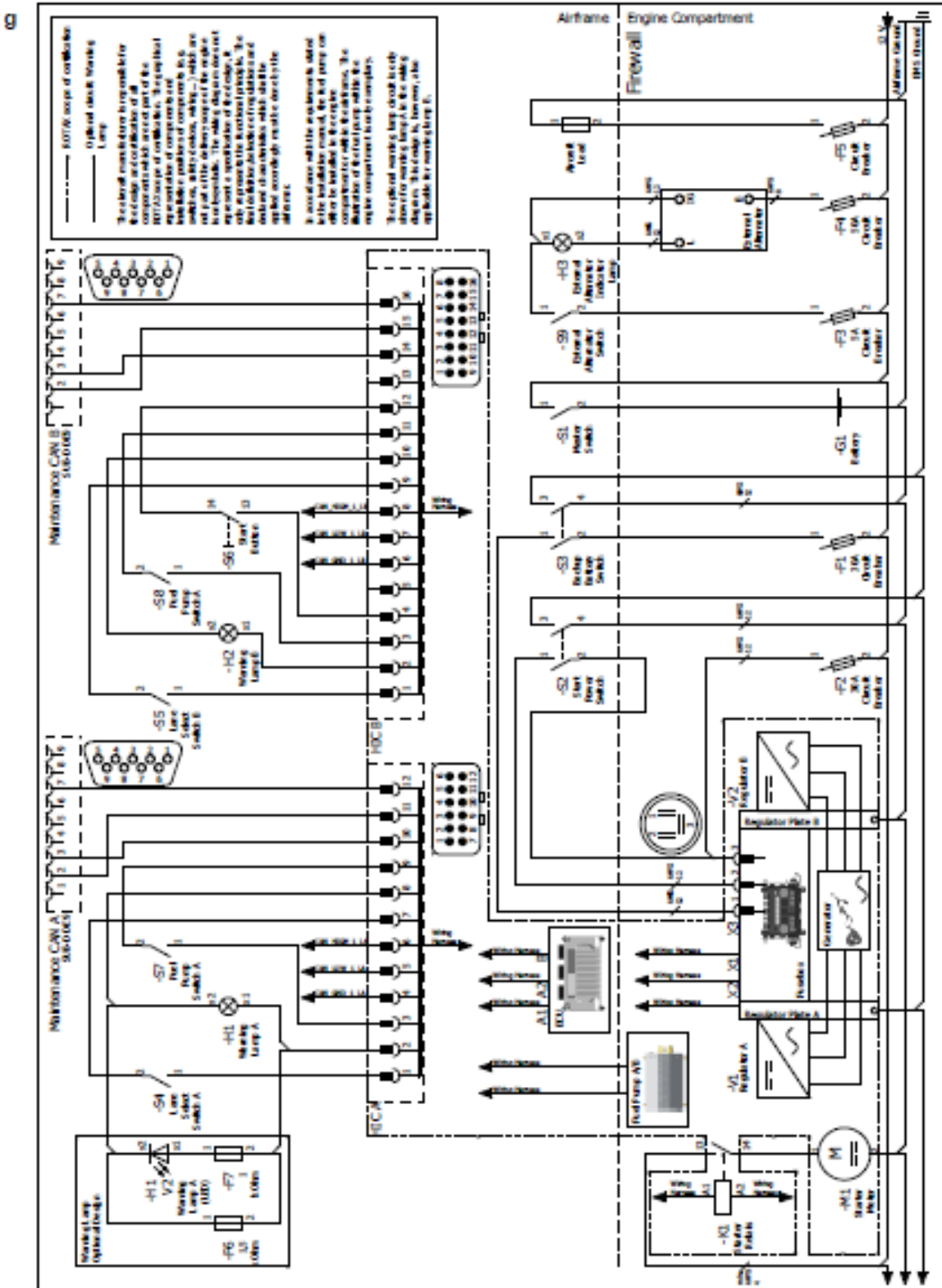

18.2 Radio – Intercom wiring





18.3 Transponder – Encoder wiring

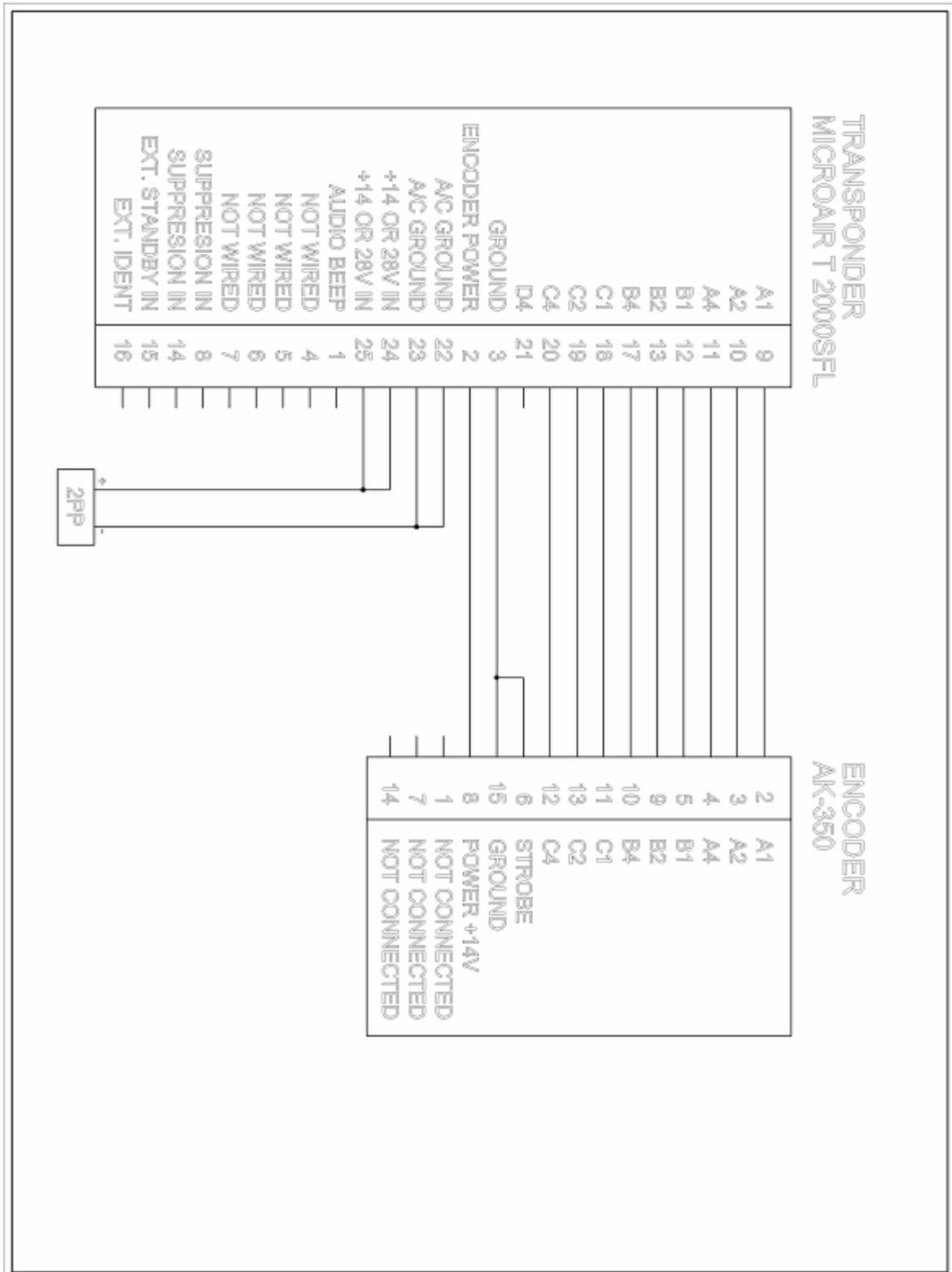

Safety directives and safety monitoring system

Table of contents	Page
19.1 Safety directives, general.....	19- 0
19.1.1 Notice of corrective action.....	19-0
19.1.2 Safety directive, structure.....	19-0
19.2 Operational safety monitoring system.....	19-1
19.2.1 Owner/operator responsibilities.....	19-1

19.1 General

Safety directives are issued by Aeropro, to ensure the safe operation of the aircraft if required. Safety Directives are issued in accordance to the applicable ASTM continued airworthiness specification. Service Directives are considered as mandatory tasks in order to maintain a condition of safe operation and compliance with the applicable original ASTM design specification.

19.1.1 Notice of corrective action

When corrective action is determined to be warranted, Aeropro will issue a notice to the known owner/operators of the affected aircrafts. These notices are titled by one of the following uppercase letters:

“SAFETY ALERT”	Notifications that require immediate action.
“SERVICE BULLETIN”	Notifications that do not require immediate action but do recommend future action.
“NOTIFICATION”	Notifications that do not require necessarily recommended future action but are primarily for promulgation of continued airworthiness information.

19.1.2 Safety directive, structure

Every safety directive consists of the following information:

- The title in bold uppercase letters and subject
- Name and contact information of the issuing entity
- Release date
- Date the notice takes effect
- Limitations for completion of any required corrective action
- Make and model of the affected aircraft
- Serial number of the affected aircraft
- Page number and the number of total pages
- Reason for the corrective action
- Subject of the corrective action
- Listing of the tools needed to accomplish the task
- List of the parts needed to accomplish the task
- Type of maintenance (line, heavy, overhaul)
- Level of certification required to accomplish the task

- Detailed instructions and diagrams as needed to perform the task
- Method to test/inspect to verify the task was accomplished properly

19.2 Operational safety monitoring system

An operational safety monitoring system is maintained by Aeropro to ensure the continued airworthiness of your aircraft. To receive and evaluate all safety of flight and service difficulty reports a feedback form is provided with this maintenance manual.

19.2.1 Owner/Operator Responsibilities

1. Each owner/operator of an airplane should read and comply with the maintenance and continued airworthiness information and instructions provided by the manufacturer.
2. Each owner/operator of an airplane shall be responsible for providing the manufacturer with current contact information where the manufacturer can send the owner/operator supplemental notification bulletins.
3. The owner/operator of an airplane shall be responsible for notifying the manufacturer of any safety of flight issue or significant service difficulty upon discovery.
4. The owner/operator of an airplane shall be responsible for complying with all manufacturer issued notices of corrective action and for complying with all applicable aviation authority regulations in regard to maintaining the airworthiness of the airplane.
5. An owner of an airplane shall ensure that any needed corrective action be completed as specified in a notice, or by the next scheduled annual inspection.
6. Should an owner/operator not comply with any mandatory service requirement, the airplane shall be considered not in compliance with applicable ASTM standards and may be subject to regulatory action by the presiding aviation authority.

Note

The feedback form is provided as attachment to this maintenance manual to submit information to the aircraft manufacturer.